



Experimental validation of the lifetime performance of a proportional 4/3 hydraulic valve operating in water

F. Majdič*, J. Pezdirnik, M. Kalin

Askerceva 6, SI-1000 Ljubljana, Slovenia, EU

ARTICLE INFO

Article history:

Received 6 May 2011

Received in revised form

27 August 2011

Accepted 30 August 2011

Keywords:

Distilled water

Proportional directional hydraulics valve

Stainless steel

Durability

ABSTRACT

One of the alternative hydraulic fluid is water, which is environmentally acceptable, low-cost and non-flammable. We have designed a new hydraulic test rig and a new water proportional control valve to investigate the tribological and hydraulic behaviour of such water-based systems under pressures of up to 16 MPa and flows of up to 30 lpm. In this work, we present the lifetime performance of all-stainless-steel valve with distilled water being used as the hydraulic fluid. The results show that the water-based valve can operate for more than 10 million cycles under industrial relevant conditions if the water cleanness is appropriately maintained.

© 2011 Elsevier Ltd. All rights reserved.

1. Introduction

With technological progress and global industrialisation, ecology is becoming more and more important for sustainable development world-wide. Power-control hydraulics is an important area of mechanical engineering [1–3], where large quantities of harmful substances (i.e., hydraulic fluids) threaten the environment with potential pollution resulting from accidents and occasional spillages [4]. It is well known that some outflows in terms of noxious hydraulic fluids occur during everyday operations, even with regular maintenance [5]. There are two possible solutions to improve this situation: the first one is to use biodegradable oils [6–10]; the second one is to use tap water as the hydraulic fluid [11,12]. The second one is much more effective and environmentally neutral, but it is more difficult to achieve. The employment of tap water in hydraulic systems implies a completely different environment for all the mechanical and hydraulic components, different dynamic and lubricating conditions, and this requires a completely or partially modified selection of materials and the design of the hydraulic system [13].

In today's industrial-scale-components market we find mainly simple, water-based components and systems, while more complex components that would enable the use of a larger amount and variety of water-based hydraulic systems instead of oil based systems are still to a large extent missing. Accordingly, there is a

clear need to develop new and more advanced water-hydraulic components. In particular, continuous-control hydraulic systems are of great interest since they are required in almost every advanced hydraulic system, but to our knowledge, the development of these water-based components has not yet taken place [14].

These reasons motivated us to develop a new proportional 4/3 directional control valve suitable for water-hydraulic applications. Several specific requirements are associated with this kind of valve when the spool and the sleeve are sliding in water. Namely, the low viscosity of water suggests that the gap between the spool and the sleeve should be very low in order to maintain a low internal leakage and a high volumetric efficiency. On the other hand, this further implies the need for very accurate manufacturing with close design tolerances (circumference and cylinder) and a low roughness. Moreover, a small gap combined with a relatively poor lubricant (i.e., water) also suggests the danger of there being high friction and wear for the contacting surfaces. For this reason, filtering will probably also play an important role in any successful operation. With these constraints identified, the materials should be properly selected, on the basis of tribological and corrosion performance, as well as taking into account machinability and costs.

It is clear that steel is not the best material for water-lubricated applications for reasons of corrosion, wear and friction. Certain types of ceramics, which are known to provide relatively low wear and friction under water lubrication [18–22] and which are actually widely used in several water-based applications, might be more appropriate. Another potential class of materials are polymers, due to their low adhesion, low specific weight and their excellent corrosion resistance. However, polymers are

* Corresponding author. Tel.: +386 1 4771 413; fax: +386 1 4771 469.

E-mail addresses: franc.majdic@fs.uni-lj.si, franci.majdic@gmail.com (F. Majdič).

Nomenclature

$Q_{L,max}$	maximal internal leakage flow of the valve [m^3/s]
Q_{np}	measured internal leakage flow [m^3/s]
n_{ip}	number of the leaving cross-sections
Δp	pressure difference in the gap [Pa]
D_m	middle diameter [m]

S	gap between spool and sleeve, when spool is in the centric position [m]
f_{ecc}	factor of eccentricity
ρ	density [kg/m^3]
ν	kinematic viscosity [m^2/s]
L	axial overlap between spool and the sleeve in the neutral position of the spool [m]

sometimes very difficult to manufacture to appropriate tolerances and experience dimensional instability, while ceramics are very expensive and suffer from fracture. Therefore, none of these materials can be easily introduced and would require detailed optimisation for any specific application. In our preliminary tribological pin-on-disc study with various pairs using alumina, PEEK, polyimide and stainless steel [15] we observed that ceramics may be one of the best materials for such an application. However, stainless steel, which is the easiest to apply and manufacture and is quite inexpensive, also showed reasonably good wear performance, although the friction was the highest among the tested materials. Thus, it is of interest to observe how the stainless steel would perform under real water-hydraulic conditions. Accordingly, in this work we have performed an experimental long-term validation test of a stainless-steel proportional 4/3 valve operating under water-lubrication conditions using our own-designed test rig and valve [16,17].

2. Water-hydraulic test rig

2.1. Requirements for the test rig

A new proportional water 4/3 directional control valve was designed to study the water-based hydraulic system. In order to reduce the testing costs, the testing valve needed to have a simple design, which could allow the fast and easy exchange of materials and provide good surface control of the spool and the sleeve. The spool and the sleeve should be small enough to fit into various surface-analyses devices (SEM, AFM, etc.). The selected material pair for the spool and the sleeve should allow precise

manufacturing in order to provide low internal leakage; the gap between them should be around 1 μm .

The water-hydraulic test rig should also allow measurements of pressure, flow, temperature, internal leakage and mechanical movement at different functional positions. It should be able to maintain a constant, stable working temperature (between 20 and 80 °C), controllable filtering conditions and, for general purposes, a comparable working flow (settable from 1 to 35 lpm) and pressure (settable from 50 to 16 MPa). It should also have its own electronic regulation.

2.2. Design characteristics

Fig. 1a shows the hydraulic circuit block-diagram of the water-hydraulic test rig. It contains a standard, commercially available axial piston pump with a flow of 35 lpm [17] at 1450 r/min and a volumetric efficiency of 97%. This pump delivers water to the actual specimen, which is in our case a proportional 4/3 directional control water valve (Fig. 2). This valve was operated with a PC in a closed loop. On the connection port A (outlet pressure) of the proportional valve, we connected a stainless-steel tube to which the pressure transmitter and the fixed orifice with a diameter of 1.5 mm at the end were connected (Fig. 3). Fixed orifices were used to simulate the load at the ports A and B of the water proportional valve. The second branch on the connection B was the same as the first one. The water relief valve was set to 16 MPa. A centrifugal water pump was used to maintain a constant temperature (air cooler) and to enable off-line filtering. The pressures on the P and T connection ports of the water proportional valve were measured during the test using two pressure transmitters. A pressure-line water filter with a rating

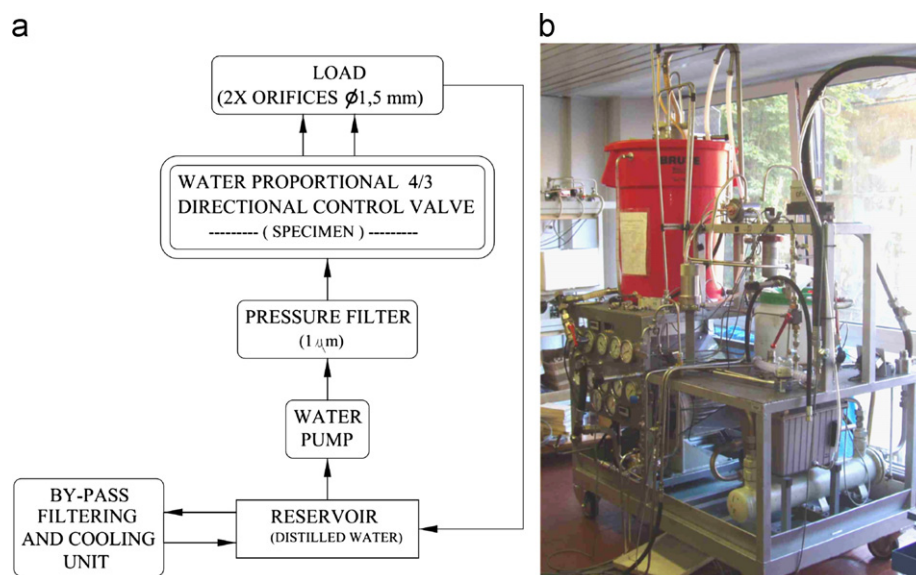

Fig. 1. (a) Hydraulic circuit block-diagram of the water test rig, (b) photo of test rig.

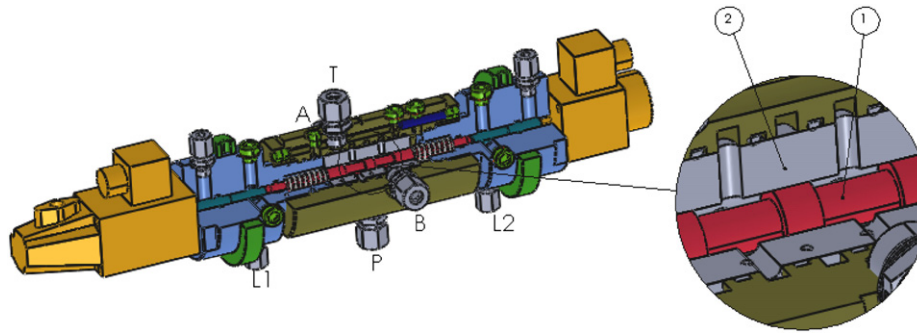

Fig. 2. Prototype of the water proportional 4/3 directional control valve (T—return-tank port, P—pressure-inlet port, A and B—working-outlet ports, L1 and L2—leakage ports).

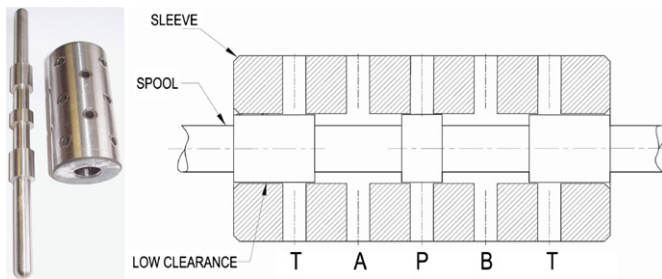

Fig. 3. The main parts and dimensions—spool and sleeve. (T—return-tank port, P—pressure-inlet port, A and B—working-outlet ports).

Table 1
The main properties of the water-hydraulic test rig.

Properties	Valve
Power	11 kW
Maximum flow	36 l/min
Maximum working pressure	160 bar
Working temperatures	5–60 °C
Hydraulic fluid	Distilled water

of 1 μm was installed in the third testing period (situation 3, as described in detail later on) on the P line—close to the water proportional directional control valve. The control of the proportional magnets, the data acquisition and the electromotors was automated through a PC. The main functional parts and the operating characteristics of the water-hydraulic test rig (Fig. 1b) are shown schematically in Table 1.

2.3. Test specimen—4/3 directional control valve

A proportional 4/3 directional spool-sliding control valve for using water as a hydraulic fluid was designed with the goal of investigating the dynamic performance of the valve related to specific working parameters and studying the tribological behaviour of various valve materials. For this purpose, the valve and its components needed to be simple, have a good external numerical control and monitoring and should allow easy replacement of the testing elements. Also, their size and shape should enable fast and easy surface analyses during and after the tests, as mentioned earlier. Fig. 2 shows a 3D model of our proportional 4/3 directional spool-sliding control valve. The two major parts that are exposed to wear and affect friction the most are the sliding spool (pos. 1) and the housing sleeve (pos. 2), shown in detail in Fig. 2. Other parts of the valve consist of the springs, the outer housing, the adaptors for the proportional solenoid and the two

proportional solenoids, one of them with the inductive transducer. All the key parts could be manufactured with sufficient accuracy and in an inexpensive way, which also allows us to use different materials.

3. Experimental

3.1. Materials and hydraulic liquid

In this investigation we used martensitic hardened stainless steel (SIST EN X105CrMo17) for the spool and the sleeve (Fig. 3), which are the two components exposed to the relative motion, and thus to wear. They served as the testing components to study the long-term performance of the newly designed valve. Both elements, i.e., the spool and the sleeve, were heat treated to a hardness of 55 HRC. The roughness of the samples was $0.25 \pm 0.15 \mu\text{m}$ and the internal clearance was about $1.75 \pm 0.7 \mu\text{m}$, which is less than typical for the oil components, but was selected with a better quality to allow approximately the same calculated internal leakage ($Q_{L,\text{max}}$) as the comparable reference oil systems [23]

$$Q_{L,\text{max}} = n_{\text{ip}} \left[\frac{\pi \Delta p D_m s^3}{12 \rho \nu L} f_{\text{ecc}} \right] \quad (1)$$

where n_{p} is the number of leaving cross-sections, Δp is the pressure difference in the gap, D_m is the middle diameter between the hole (in sleeve) and the pin (spool), s is the gap between the spool and the sleeve in the centric position, ρ is the density, ν is the kinematic viscosity and f_{ecc} is the factor of eccentricity.

The hydraulic liquid used in the test was distilled water. This was to ensure a controlled environment that does not reflect the water type, which can vary at different locations in the world in terms of pH and mineral composition.

3.2. Procedure and testing parameters

The wear performance was “monitored” during the test indirectly using ex-situ measuring of the internal leakage at a selected number of cycles: 35,000, 95,000, 335,000, 545,000, 800,000, 1,155,000, 1,255,000, 2,400,000 and 2,500,000 cycles. An internal leakage of 100 ml/min was considered acceptable, which is the same as in typical oil valves. Namely, the internal leakage should remain lower than 1% of the maximum fluid flow during the test. Leakage was measured at ports A, B and T, while the pressure at port P was 16 MPa.

A typical, comparable oil-valve is expected to work for about 2.5 million of cycles, which corresponds to almost half a year of operation for 8 h per day at maximum load with a frequency of 1 Hz. This was set as the primary lifetime goal for our experiment. However, the results showed that this was easily achieved, so our

testing plan was modified and the test was continued under different conditions to make maximum use of the set-up that was already in place.

We tried to evaluate the importance of filtering, so first we continued the test without any filtering. After approximately 4 million cycles, a major failure occurred. The parts were dismantled and repaired (polished), but the damage was relatively small so the test could continue.

In the third test stage, based on our experience of the importance of filtering, we ran the test again with filtering, but this time, even better than in the first stage (0–2.5 million cycles). The test ran for 10 million of cycles, and then the test was stopped in spite of acceptable performance, as will be presented in the results section.

The three test phases are presented in Fig. 4.

Another way of monitoring the performance during the test involved visual inspections of the spool surface and SEM images that were taken at different intervals. Namely, the valve was

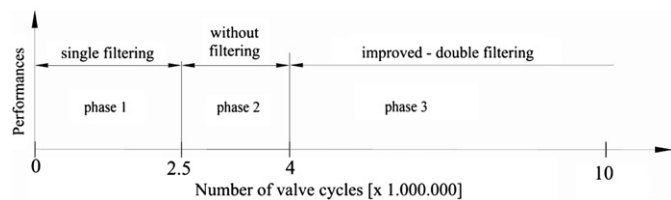

Fig. 4. Three different regimes of the water proportional directional control lifetime test.

analysed before the test, and was dismantled after 95,000, 2,670,000 and at the end of the test at 10,000,000 cycles. At every inspection interval, all the parts of the valve were carefully dismantled, cleaned in ethanol, analysed and then cleaned again in ethanol and mounted on the valve to continue the test. The same inspection, together with the roundness and roughness measurements, and the repair, was also performed during the occurrence of the major failure at 4,010,000 cycles, when the spool was blocked in the sleeve.

3.3. Testing parameters

The maximum possible inlet pressure at the P connection (see Figs. 2 and 3) on the specimen (water proportional 4/3 valve) was 16 MPa, which enabled the maximum working pressures at the A and B connections – depending on the flow through the orifices (Fig. 1—load) – 12 MPa. The working flow through the orifices was 20 lpm. The frequency of the spool was 5 Hz and its control signal was $\pm 100\%$ of the spool stroke.

Schematic diagrams of the theoretical input driving signal (Fig. 5a) and the experimentally obtained values are presented in Figs. 5b and 6.

Fig. 6a shows the measured pressure on the inlet port P (see Figs. 2 and 3). The pressure responses of the different positions of the spool at the working ports A and B are shown in Fig. 6b. From the measured signals it is clear that the specimen (i.e., the sliding spool and the sleeve) in the water proportional 4/3 directional control valve was dynamically loaded at all three ports: P, A and B.

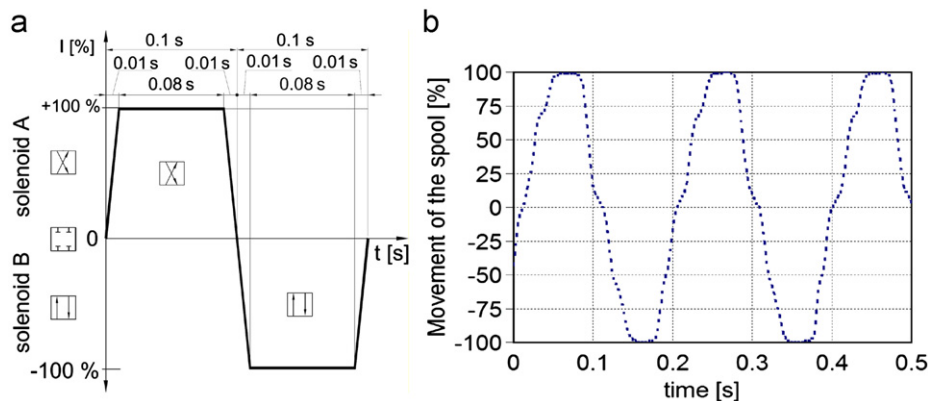

Fig. 5. (a) Theoretical input signal, and (b) response-measured signals of the spool position (pressure=16 MPa, flow=20 lpm, frequency=5 Hz).

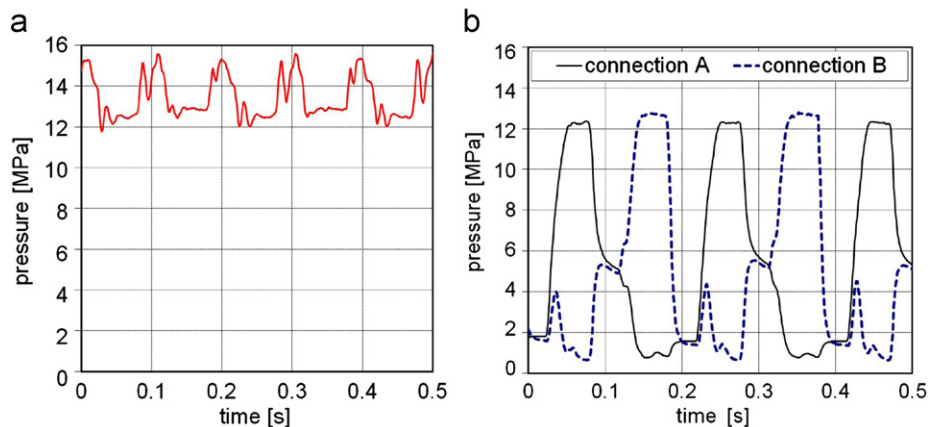

Fig. 6. Example of measured pressures (a) at P and (b) at A and B connections of water 4/3 directional control valve as a function of time (pressure=16 MPa, flow=approx. 20 lpm, frequency=5 Hz).

4. Results

4.1. Phase 1—testing with single filtering

Fig. 7 shows the internal leakage measurements during phase 1, i.e., from the start to 2.5 million cycles. Each measurement (a dot) on the full line in the diagram represents the mean value of at least three measurements of internal leakage at 40° and pressure 16 MPa. These results correspond to an increase in the internal leakage from an initial 0.036 l/min up to 0.0843 l/min, after 2.5 million cycles. The increase is continuous and gradual; however, it should be noted that the leakage value represents only 0.2% of the maximum outflow of the water pump, which is a very small internal leakage and far below acceptable operating limits, even for comparable oil-hydraulic systems. There was some variation noticed in the measurements, which may be due to different positions of the spool during the time of the internal leakage measurements. Namely, it is known that the exact position of the spool inside the bore of the sleeve could affect some variations in the internal leakage [23]. Another source of the variation is the measurement uncertainty.

Fig. 8 shows schematically the two positions where the surfaces were analysed; they were selected on the assumption that these are the most relevant wear-sensitive locations on the spool (indicated by arrows A and B). These locations were verified at several positions circumferentially. Optical and SEM analyses were performed.

Fig. 9a and b shows the surfaces at locations A and B (as indicated in Fig. 8) before the test. Several scratches are visible in the vertical direction, which resulted from the manufacturing during the rotational grinding and polishing. Other scratches, as well as some edge damage, are micro-scale defects that occur during the handling of the spool. It should be mentioned that it is mainly the horizontally oriented scratches that increase the internal leakage as they lie in the direction of the spool's movement, rather than those that are perpendicular to the direction of motion.

The SEM images in Fig. 10 show the sliding surface of the spool after 95,000 cycles. Two characteristic types of damage can be observed. The edges (Fig. 10a) are slightly rounded due to the erosion of particles in the water flow, as well as occasionally deformed or fractured, which is, however, a consequence of the manipulation of the spool prior to the test. The top spool surface,

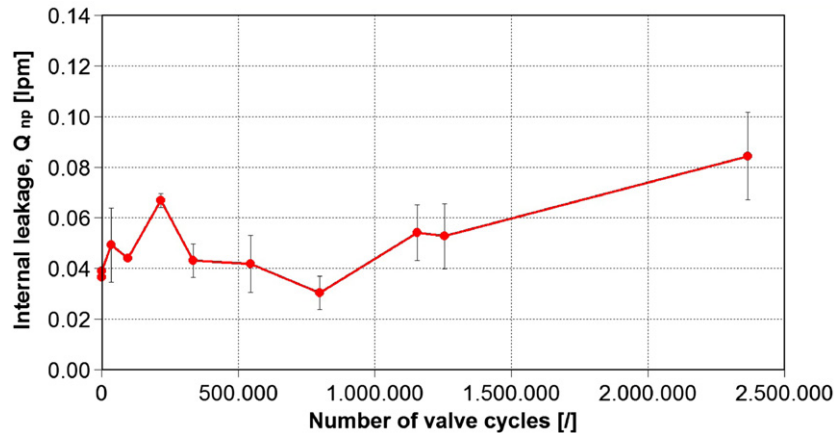

Fig. 7. Internal leakage of water directional 4/3 proportional control valve from start up to 2.5 million cycles. (pressure=16 MPa, flow=approx. 20 l/min, frequency=5 Hz, $T_{\text{water}}=40$ °C.)

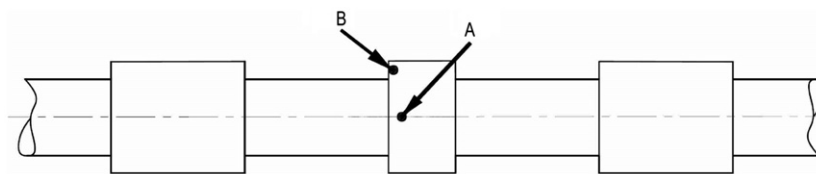

Fig. 8. Schematic of analysed positions of the spool investigated by SEM.

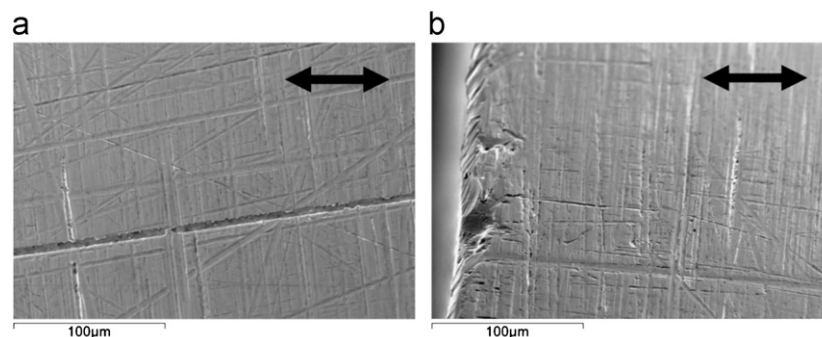

Fig. 9. Representative sliding surfaces of the spool prior to the test at location (a) A and (b) B—as indicated in Fig. 8. (Arrows indicate the direction of spool motion.)

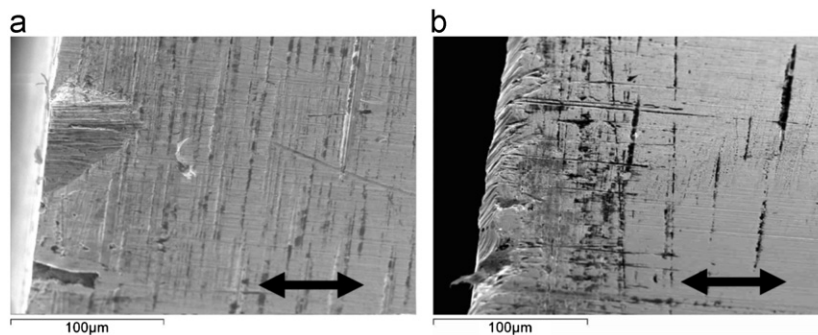

Fig. 10. Representative sliding surfaces of the spool during the lifetime test after about 95,000 cycles, (a) surface on place A and (b) surface on place B. (Arrows indicate the direction of spool motion.)

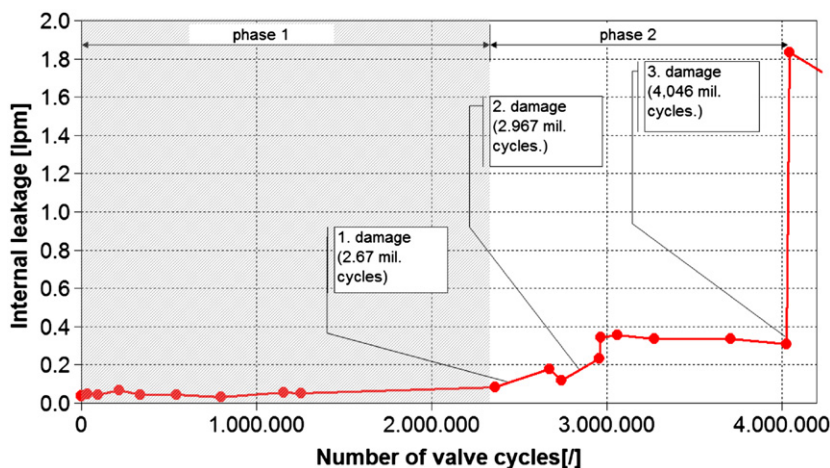

Fig. 11. Internal leakage of water directional 4/3 proportional control valve in phase 2 from 2.5 to 4 million of cycles. (pressure=16 MPa, flow=20 l/min, frequency=5 Hz, $T_{\text{water}}=40\text{ }^{\circ}\text{C}$.)

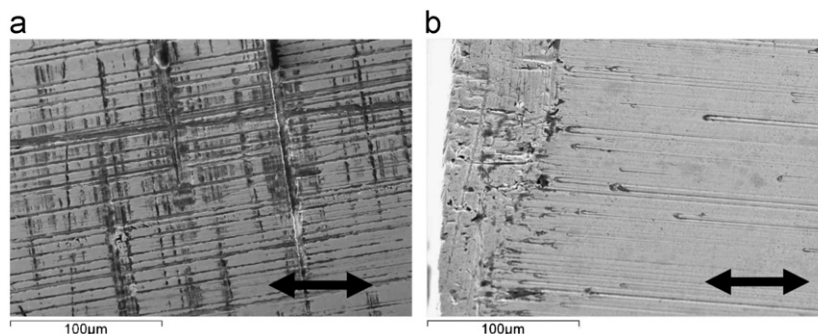

Fig. 12. Representative sliding surfaces of the spool during the lifetime test after 2.67 million cycles, (a) surface on place A and (b) surface on place B. (Arrows indicate the direction of spool motion.)

i.e., at location B, (Fig. 10b) is obviously smoothed due to two- and three-body abrasion, but no severe damage can be observed. In addition, at some positions, some deeper scratches can be seen. Presumably, these are the remaining deeper scratches from the manipulation of the spool prior to the tests.

4.2. Phase 2—testing without filtering

The testing regime after 2.5 million cycles (Fig. 4) was changed with respect to the filtering. Namely, no filtration of the water was performed in the period from 2.5 to 4 million cycles. In this period three notable types of damage occurred on the sliding surfaces of the spool and the bore of the sleeve. The same problem occurred three times: some wear debris was locked between the

spool and the sleeve, obviously due to the lack of filtering. The spool stopped moving, and dismounting was necessary to relieve the spool. Due to this, some surface damage in the form of a scratch occurred. After each blockage, however, the testing spool and the sleeve were carefully polished. Polishing resulted in an increased clearance between the spool and the sleeve, which led to increased leakage, as seen in Fig. 11.

Fig. 12a and b shows several clearly visible horizontal scratches after 2.67 million cycles using SEM. The SEM images were recorded after the first damage with spool blocking occurring in the water valve (see Fig. 11). The horizontal scratches are probably the result of the abrasive action from numerous hard particles in the water, which are present due to lack of filtering. Both surfaces, i.e., the spool and the sleeve, showed the same type

of damage, i.e., many scratches. However, with subsequent polishing (spool repair as a result of the wear-debris blocking), these scratches were removed, and the internal leakage increased, as mentioned before, and is shown in Fig. 11.

4.3. Phase 3—testing with double filtering

After 4 million cycles (until the end of the test at 10 million cycles), improved double filtering was included in the water-hydraulic system. Both by-pass and additional pressure filters were applied with a filtration rate of 1 μm . During this testing period no blocking or any other catastrophic damage occurred and the motion of the spool followed the input signals very consistently Fig. 13.

The internal leakage that was measured during the period from 4 to 10 million cycles varied quite significantly, most probably due to the increased clearance between the spool and the sleeve after the repairs at earlier stages. The motion of the spool was thus less centric and the positions of the spool at the time of the internal leakage measurement also affected these results. The measured internal leakage at the end of the testing procedure was 1.55 lpm, which is approximately 4% of the whole flow of the pump. Although the increase in the internal leakage due to the repair was very significant after 4 million cycles, the internal leakage at the end was still within the operational limits [24]. Moreover, there was no obvious increase observed from 4 to 10 million cycles.

Fig. 14a and b shows the surfaces at the end of the lifetime test, i.e., after 10 million cycles. The surfaces show no severe signs of damage, and are surprisingly like those prior to the test, Fig. 9a

and b. There are some scratches observed, primarily in the circumferential direction, which originate from manufacturing and repair, rather than the wear during operation. No major scratches or signs of damage due to sliding (direction of motion) could be observed (Fig. 14b). However, we can see some small, shallow pits (Fig. 14a), which are most probably due to cavitation, which is expected at this location [25,26]. A detail from one of the most damaged locations on the spool indicates that these pits developed a size of about 1–5 μm during the 10 million cycles (Fig. 15). Nevertheless, under the present conditions, these pits did not have a significant influence on the internal leakage or otherwise reduce the performance of the system, which can be claimed on the basis of the internal leakage measurements. In this testing period (from 4 to 10 million cycles) the sliding surfaces

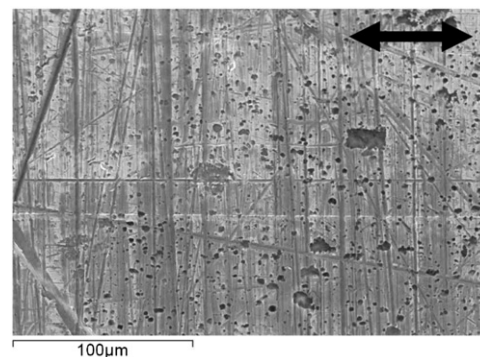

Fig. 15. Cavitation wear after 10 million cycles found on the sliding surface of the spool. (Arrow indicates the direction of spool motion.)

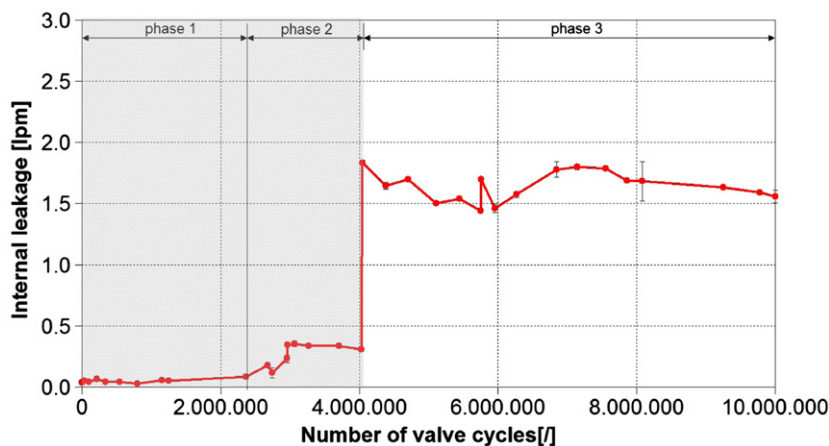

Fig. 13. Internal leakage of water directional 4/3 proportional control valve from 4 to 10 million cycles. (pressure=16 MPa, flow=20 l/min, frequency=5 Hz, $T_{\text{water}}=40\text{ }^{\circ}\text{C}$).

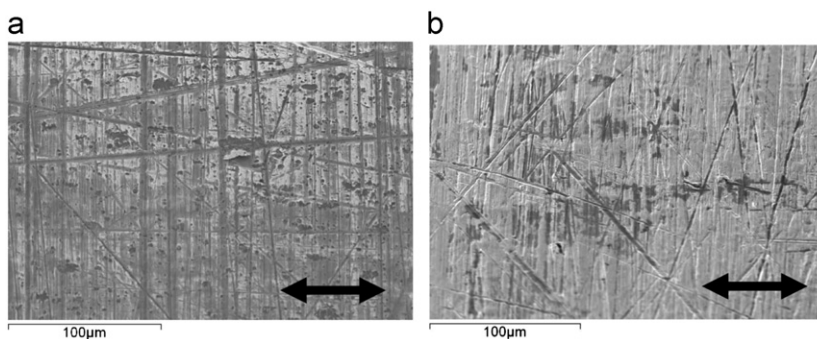

Fig. 14. Representative sliding surfaces of the spool during the lifetime test after 10 million cycles, (a) surface on place A and (b) surface on place B. (Arrows indicate the direction of spool motion.)

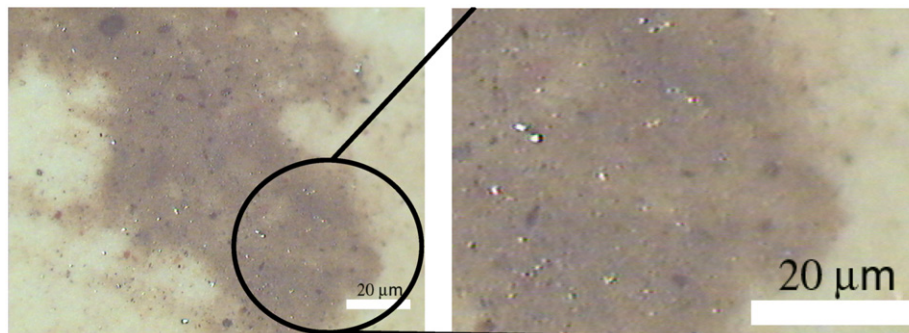

Fig. 16. Metallic particles found in the water-hydraulic reservoir in phase 2, without filtering.

were relatively smooth, owing to the much better and reliable double filtering, which significantly reduced the surface damage and improved the reliability of the water-based valve.

Other components, except the valve (spool and the sleeve), in the water-hydraulic system were not specifically investigated during the test. However, we did not notice any problem during the operation, and almost no damage or wear phenomenon was observed after the system was dismantled after the 10-million-cycle test.

5. Discussion

The lifetime performance of a water proportional 4/3 directional control valve was investigated for three different filtering regimes. In the first regime (phase 1—with 5 μm by-pass filtering), only a moderate and, according to normal practise, acceptable increase in internal leakage was noticed (Fig. 7), with mild polishing of the surface during the running-in. The internal leakage in phase 1 was thus only 0.2% of the maximum outflow of the water pump, which is a very small amount. The same situation can be observed in the last stage, i.e., phase 3 (with 1 μm double filtering), where the filtering was again obviously adequate (0.2% of the maximum outflow of the water pump), and even improved, compared to phase 1. However, some fluctuations were found, mainly due to spool repairs. The conditions in these two regimes were more than satisfactory, with an almost negligible total increase in the internal leakage of less than 0.1% of the maximum outflow of the water pump per million cycles, which is far below the acceptable performance, even for steel valves [24].

On the other hand, the test without the filtering in phase 2 resulted in increased wear and damage in the form of scratches and edge erosion, and even a spool-motion blockade due to wear-debris entrapment between the spool and the sleeve. Many wear debris of about 1–3 μm were noticed in this phase (see Fig. 16), which was not the case in the other two phases. Obviously, filtering plays a major role in water-based systems, probably even more important than in oil-hydraulic systems, because of the required narrower clearances in these valves compared to the oil-based valves.

It is, however, surprising to find that even though the blocking of the spool occurred, the system continued to operate up to 10 million cycles (Fig. 13) after the de-blockade and spool repair (surface polishing), without increasing the total internal leakage above the expected performance level of a comparable reference oil-based system, i.e., of around 5%. The test was ended during these normal operating conditions due to the far-exceeded performance over 10 million cycles of operation.

Accordingly, the lifetime test of the water-based hydraulic valve was successfully performed up to 10 million cycles and stopped before detrimental wear or surface damage or any other

system component damage. The wear mechanisms that were observed were abrasive scratches and cavitation pits, as well as some edge erosion due to the impacts of water-flow debris. However, the extent of these phenomena was below the acceptable limits. What is more, most of the surface damage and wear occurred as a consequence of the incorrect filtering method (phase 2), not during the normal operation with the appropriate filtering during phases 1 and 3.

Accordingly, the major parameter that must be kept under strict control was found to be the wear-debris filtering, which may otherwise cause damage to the valve and consequently a malfunction of the whole water-hydraulic system. The low internal clearances in water-based systems seem to be even more sensitive to this phenomenon compared to conventional oil hydraulics due to the low clearances. On the other hand, the selection of stainless steel as a material for the tested specimens, showed acceptable wear under the proper operating conditions with filtering. However, the expected higher friction (not measured here), typical for steel in water conditions, compared to state-of-the-art water-lubricated materials, such as ceramics [18–22], did not cause any problem or any functional reduction in the spool motion (see Figs. 6 and 7). Namely, in our comprehensive study of water-based hydraulics [27], we have measured some small delay of around 3 ms in the spool motion compared to the equivalent oil system, but at 5 Hz, as used in this work, this delay still satisfies all the required functional properties and does not affect the operating performance [27].

Accordingly, with the proper design and clearances, the correct filtering method, the appropriate stainless-steel pre-treatment (i.e., hardened steel) and the right testing conditions, this new water-hydraulic system and the proportional 4/3 valve were validated and showed an excellent industrial-parameters-validated performance, which therefore confirms the great potential for the further development of water-based systems.

6. Conclusions

1. A newly designed, full stainless-steel, proportional 4/3 directional control sliding type of valve was successfully run in distilled water for 10 million cycles with appropriate performance in terms of internal leakage and wear. This testing time is even longer than the required life of such a valve in typical industrial applications.
2. The surface damage to the spool and the sleeve was very moderate in the form of minor scratches and some cavitation pits, which overall did not affect the performance of the valve.
3. The internal leakage of the tested valve at 12 MPa and the water flow of 20 l/min was below 5% of the maximum pump flow throughout the test, indicating the industrial relevance of the performance of the tested system. Most of

the system-performance reduction was during the stage with improper filtering.

4. With two different types of filtering (5 and 1 μm filters), the filtering of water was found to be one of the key parameters for the successful operation of a water-based hydraulic valve, which in the case of operation without filtering very soon led to the malfunction of the valve. In contrast, good filtering allowed very low wear and leakage.

Acknowledgements

The authors are sincerely grateful to the company Tajfun d.o.o. Planina pri Sevnici, Slovenia) for their financial and technical support. For the financial support of this research we are sincerely grateful also to the Slovenian Research Agency.

References

- [1] Murrenhoff H. Grundlagen der Fluidtechnik Teil 1: Hydraulik. 5th ed. Aachen: IFAS; 2007.
- [2] Findeisen D. Ölhydraulik. 5th ed. Berlin Heidelberg: Springer-Verlag; 2006.
- [3] Murrenhoff H. Servohydraulik. 1st ed. Aachen: IFAS; 1998.
- [4] Kržan B, Vižintin J. Environmentally adapted lubricants. *Ventil* 2009;15(3): 280–6.
- [5] Bartz WJ. Lubricants and the environment. *Tribology International* 1998;31:35–47.
- [6] Kalin M, Vižintin J. A comparison of the tribological behaviour of steel/steel, steel/DLC and DLC/DLC contact when lubricated with mineral and biodegradable oils. *Wear* 2006;261(1):22–31.
- [7] Barriga J, Kalin M, Van Acker K, Vercammen K, Ortega A, Leiaristi L. Tribological performance of titanium doped and pure DLC coatings combined with a synthetic bio-lubricant. *Wear* 2006;261(1):9–14.
- [8] Kalin M, Vižintin J, Vercammen K, Arnšek A, Barriga J, Van Acker K. Tribological performance of lubricated DLC coatings using biodegradable oils. *The Coatings in Manufacturing Engineering* 2004:457–65.
- [9] Igartua A, Aranzabe J, Barriga J, Rodríguez B. Tribological study for the application of biodegradable lubricants in the Industry. In: Ronkainen H, Holmberg K, editors. COST 516 tribology symposium proceedings, VTT, Espoo; 1998. p. 135–146.
- [10] Kalin M, Majdič F, Vižintin J, Pezdirmnik J, Velkavrh I. Analyses of the long-term performance and tribological behaviour of an axial piston pump using diamond-like-carbon-coated piston shoes and biodegradable oil. *Journal of Tribology* 2008;130:11013–1–8.
- [11] Backe W. Water- or oil-hydraulics in the future. In: Proceedings of the sixth scandinavian international conference on fluid power, SICFP 1999, Tampere, Finland. p. 51–65.
- [12] Kitagawa A. Co-operation between universities and water hydraulic companies in Japan. In: Proceedings of the sixth scandinavian international conference on fluid power, SICFP 1999, Tampere, Finland.
- [13] Trostmann E. Water hydraulics control technology. Lyngby: Technical University of Denmark; 1996.
- [14] Koskinen K, Leino T, Riipinen H. Sustainable development with water hydraulics—possibilities and challenges. In: Proceedings of the 7th JFPS international symposium in fluid power, Toyama, Japan, vol. 1; 2008. p. 11–18.
- [15] Majdic F, Pezdirmnik J, Kalin M. Comparative tribological investigations of continuous control valves for water hydraulics. In: Proceedings of the 10th international conference on fluid power, SICFP'07, Tampere, Finland; 2007.
- [16] Majdic F, Pezdirmnik J. Advances in water power-control hydraulics experimental research. *Journal of Mechanical Engineering* 2008;54(12):841–9.
- [17] Majdic F, Pezdirmnik J. Oil- and water-based continuous control valve. *Industrial Lubrication and Tribology* 2010;62(3):136–43.
- [18] Chen M, Kato K, Adachi K. The comparisons of sliding speed and normal load effect on friction coefficients of self-mated Si_3N_4 and SiC under water lubrication. *Tribology International* 2002;35:129–35.
- [19] Kalin M, Novak S, Vizintin J. Wear and friction behaviour of alumina ceramics in aqueous solutions with different pH. *Wear* 2003;254:1141–6.
- [20] Kalin M, Novak S, Vizintin J. Surface charge as a new concept for boundary lubrication of ceramics with water. *Journal of Physics D: Applied Physics* 2006;39:3138–49.
- [21] Andersson P. Water-lubricated pin-on-disk tests with ceramics. *Wear* 1992;154:37–47.
- [22] Kalin M, Jahanmir S, Drazic G. Wear mechanisms of glass-infiltrated alumina sliding against alumina in water. *Journal of the American Ceramic Society* 2005;88:346–52.
- [23] Pezdirmnik J. Tok tekočine skozi reže v hidravličnih sestavinah : (tok kapljevine skozi reže med soležnimi vzporednimi ploskvami brez medsebojne relativne hitrosti)=Fluid flow through gaps in hydraulic components:(liquid flow through gaps between parallel surfaces without relative velocity). *Strojnikski Vestnik* 2001;47(5):210–6.
- [24] Casey B. Insider secrets to hydraulics. Australia: West Pert; 2002.
- [25] Zhou H, Yang H. Diagnostic of cavitation inception in water hydraulic piston pump. In: Proceedings of the sixth scandinavian international conference on fluid power, SICFP 1999, Tampere, Finland.
- [26] Suzuki K, Urata E. Improvement of cavitation resistive property of a water hydraulic relief valve. In: Proceedings of the eight scandinavian international conference on fluid power, SICFP 2003, Tampere, Finland.
- [27] Majdič F. Water as a liquid in power-control hydraulic; Voda kot kapljevina v pogonsko-krmilni hidravliki. Doctoral Dissertation (in Slovene). Ljubljana; 2010.