

# TRIBOLOGICAL INVESTIGATIONS OF MATERIALS FOR WATER HYDRAULICS

Franc Majdič, Jožef Pezdirnik, Mitjan Kalin  
Centre for Tribology, Technical Diagnostics and Hydraulics  
Faculty of Mechanical Engineering  
University of Ljubljana, Slovenia

## Abstract

Reduction of oil usage and its almost daily increasing price is directing world development in the field of hydraulic fluids towards alternative sources. One possible alternative source is water, which is environmentally blameless, low-cost and nonflammable.

Taking into consideration the body accessible information about water power-control hydraulics (PCH), we constructed a simple hydraulic test rig to investigate the basic tribological and hydraulic behaviour of such systems under pressures up to 150 bar and flows up to 30 L/min. With that aim we designed and constructed a proportional 4/3 directional continuous acting spool type sliding valve, a simplified model but still with the shape and working parameters resembling real valves. Tribological properties and static as well as dynamic behaviour can be investigated on this model by employing components of different materials. All other applied components of this test rig were taken from normal serial production, meaning that these components are available on the market. In this work, a design of the test rig and testing schemes are presented, while the real-scale preparation and testing procedures are on-going.

However, in order to ensure a satisfactory useful life time of the proportional 4/3 directional control valve, an optimal tribological pair is required in the valve. With this aim in mind, we carried out preliminary tribological tests of different material-pairs lubricated with additive-free distilled water. The tested materials were stainless steel, PI, PEEK and Al<sub>2</sub>O<sub>3</sub>. The results of the preliminary tribological tests of different material pairs are described in this paper. The best material pair considering low wear and a low coefficient of friction was obtained with graphite-modified PEEK composite against Al<sub>2</sub>O<sub>3</sub>.

**Keywords:** high pressure water systems, power-control hydraulics, distilled water, proportional directional control sliding type valve, tribological properties, pin-on-disk, stainless steel, PI, PEEK, Al<sub>2</sub>O<sub>3</sub>

## 1. Introduction

A great number of countries are making considerable efforts to protect their environment. In the past in Slovenia we have investigated bio-degradable fluids [1 - 4] and their application in power-control hydraulics [5], especially for machines working in environmentally sensitive areas. Yet additives must be added to such fluids, and they are not environmentally blameless. But the use of tap water as a hydraulic fluid has no adverse effects on the environment. That is the reason for our decision to investigate tap water as a hydraulic fluid for power-control hydraulics (PCH). Several components for acceptable high pressures using this fluid have already been developed and are available on the market [6, 7, 8, and 9]. In the field of hydraulic valves the ball- or poppet-seat type of valves are usually available on the market at designer's or customer's disposal [6 and 7]. But this type of valve is badly suited for continuous regulation functions, especially for continuous and fine flow regulation. Other weak points of such valves are their large dimensions and quite complicated construction [7].

Using water instead of mineral oil as the pressure medium entails significant changes in the physical parameters [10]. Compared to mineral oil water differs, in the following physical parameters which are important for PCH: about 30- times lower viscosity (at 20°C) and thus poorer lubrication, a more than 12 million-times higher vapour pressure (at 50°C), and 33 to 60 % higher bulk modulus (at 20°C). Water also provokes corrosion of parts that are not corrosion resistant.

In designing spool sliding valves for water power-control hydraulics we have to consider that the very low viscosity of water, compared to that of mineral oil, plays a dominant role. Assuming a lower viscosity, Trostmann et al [10] found that in order to ensure the same amount of leakage using water instead of mineral oil as the pressure medium, a one-third reduction in the radial space gap is required, holding other parameters as constant. This suggests that the tolerances and dimensional characteristics are much more strict and demanding in water than oil. This further imply more severe contact conditions and poorer performance under the same conditions is anticipated.

The higher energy density of the pressure fluid flow in water hydraulics and the higher vapour pressure of water compared to that of mineral hydraulic oil may cause serious problems of erosion (via cavitation) and abrasion, higher leakage flows and problems in valve functioning [10]. A lower viscosity also means a lower lubricating film, which can increase friction and wear, unless we use suitable material-pairs [11].

Furthermore, the dynamic behaviour of water power-control hydraulic systems (PCHS) differs significantly from that of mineral oil PCHS, especially in pressure amplitudes and oscillating periods in the case of underdamped oscillatory motions. The bulk modulus of water is about 70 % higher than that of mineral oil. The results of a mathematical model [12 and 13] suggest about 24 % higher pressure amplitudes in water PCHS compared to those of mineral oil PCHS, other system parameters being the same for both systems.

However, the actual dynamic performance, tribological properties, and resistance to motion must be – in addition to theoretical predictions- verified in tribological and real-scale testers. Accordingly, in this work we present a newly developed dedicated hydraulic test rig for testing the water-based hydraulic systems, which can use testing components from different materials. For comparison, conventional “oil-test” can also be performed. In addition, a preliminary model tribological tests with different material combinations consisting from ceramics, plastics and stainless steel are presented. Present data suggest that the most promising material pair resulting in a low wear and a low coefficient of friction was obtained with graphite-modified PEEK composite against Al<sub>2</sub>O<sub>3</sub>.

## **2. Construction of test rig**

### **2.1. Project requirements**

The water power-control hydraulic (PCH) testing rig should be simple, controllable, and it should represent an almost real hydraulic system. It should enable to:

Measure pressure, flow and temperature before and after the testing specimen – namely, a proportional directional control valve.

Assure a constant flow through the proportional directional control valve independently of a possible decrease in pump volumetric efficiency.

Simulate loading and control its response.

Assure variation of loading.

Assure controlled temperature value of the fluid (via cooling).

Assure a full automatic life-cycling test.

Assure measurement of the dynamic response of the system.

Assure measurement of the dynamic response of the specimen – the proportional directional control valve.

Assure simple measurement of the leakage of the specimen – the proportional directional control valve.

## 2.2 Construction of water hydraulic test rig

We constructed a water PCH test rig which satisfies all the project demands. Figure 1 shows the hydraulic circuit of our test rig. It contains a standard Danfoss axial piston pump, type PAH 25 (Fig. 1, pos. 4.0), with a flow rate of near by 35 L/min [6] at 1450 r./min and a volumetric efficiency of 97%. This pump delivers water through a pressure-compensated flow control valve (Fig. 1, pos. 19), which ensures a constant flow of 30 L/min through the specimen – the proportional directional control valve (Fig. 1, pos. 20). This proportional directional control valve is controlled from a PC in a closed loop. On connection A of the proportional valve, we have a flexible hose of 2 m, a pressure transmitter, and a double-acting through-rod hydraulic cylinder (Fig. 1, pos. 22). The second branch from connection B to the hydraulic cylinder is equal to the first, already described. On the end of the cylinder's rod a translator-moving mass (Fig. 1, pos. 24.1) with minimum friction coefficient is connected. This linear oscillating mass is used for short-term dynamic tests. For life time cycle tests of the proportional directional control valve, another double-acting through-rod hydraulic cylinder (Fig. 1, pos. 124.1) is used instead of the moving mass.

With this hydraulic cylinder we simulate a load through the double throttle (Fig. 1, pos. 127) and four check valves (Fig. 1, pos. 126). The hydraulic medium in this hydraulic cycle is mineral oil. This oil-hydraulic cycle has its own pump (Fig. 1, pos. 101), which delivers oil to the hydraulic cylinder (Fig. 1, pos. 124.1) with the residual flow through an air cooler and filter. The main aim of this pump is to provide an oil flow for cooling and filtering. Its second aim is not driving or powering the hydraulic cylinder, but just assurance of inlet flow. Return flow from the cylinder is taken through an air cooler and oil filter. This solution assures near constant temperature conditions of the oil hydraulic cycle which simulates load.

The assemblage of pipe valve and double T-pipe-connectors (Fig. 1, pos. 14.i and 15.i) give us an opportunity for periodical control of flow and temperature at different positions. The water relief valve (Fig. 1, pos. 6) is set to 160 bar. We used a dynamic centrifugal water pump (Fig. 1, pos. 13) to maintain constant temperature (air cooler) and to enable off-line filtering.

Control of the proportional magnets (Fig. 1, pos. 26.1 and 28.1), data acquisition and control of the electro-motors is provided by and automated through a PC.

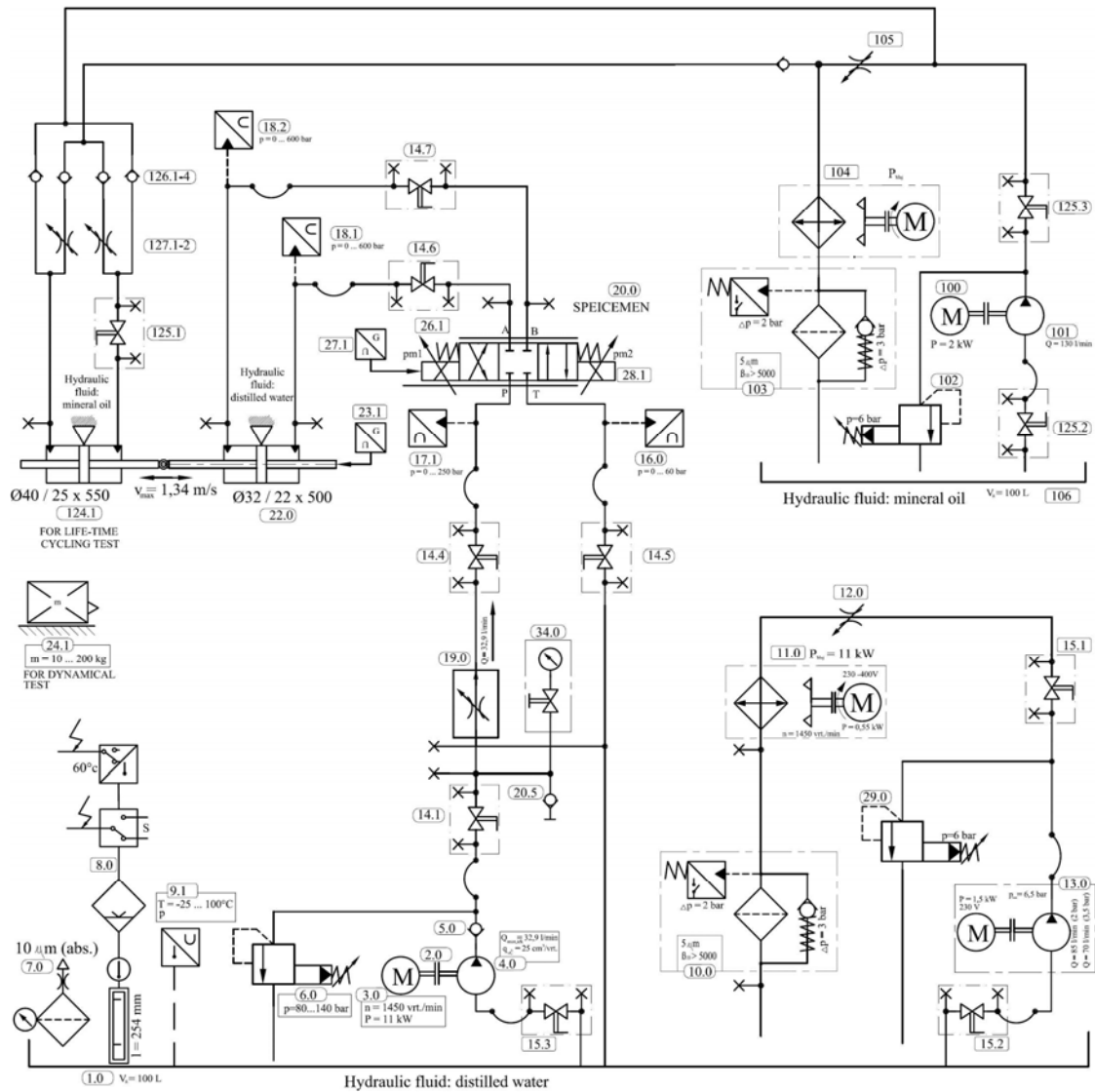
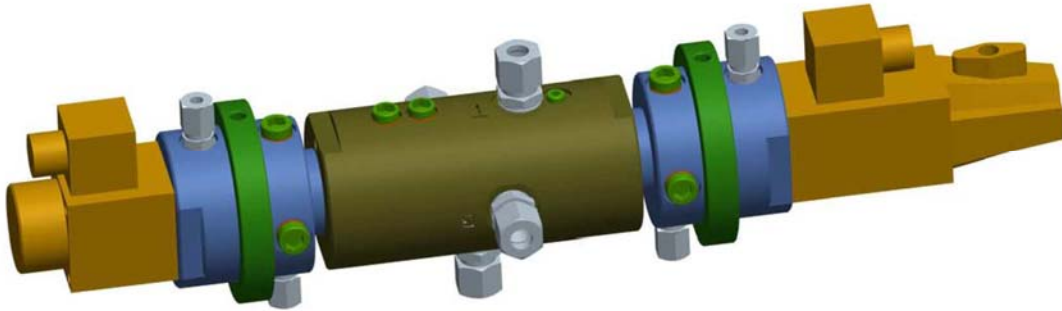

**Figure 1:** Hydraulic circuit of water PCH test rig

### 2.3 Construction of proportional 4/3 directional control valve

As the seat type of valve, either poppet or ball-type, is not convenient for use as a continuous valve, we designed and constructed a proportional 4/3 directional control sliding valve. It is used in our water hydraulic test rig for motion control of the water double acting hydraulic cylinder with double-ended rod.

In order to study the tribological performance using different materials, a simple, well-controlled and easily replaceable testing samples need to be used. Also, their size and shape should enable fast and easy surface analyses. For this purpose, we designed and manufactured functional prototype of water proportional 4/3 directional sliding control valve as shown in three-dimensional model in figure 2.



**Figure 2:** 3D model of a functional prototype of a proportional 4/3 directional sliding control valve

Main parts of the functional prototype of a proportional 4/3 directional sliding control valve are (figure 3): sliding spool, housing sleeve, outer housing, adaptors for proportional solenoid, and two proportional solenoids, one of them with inductive transducer.

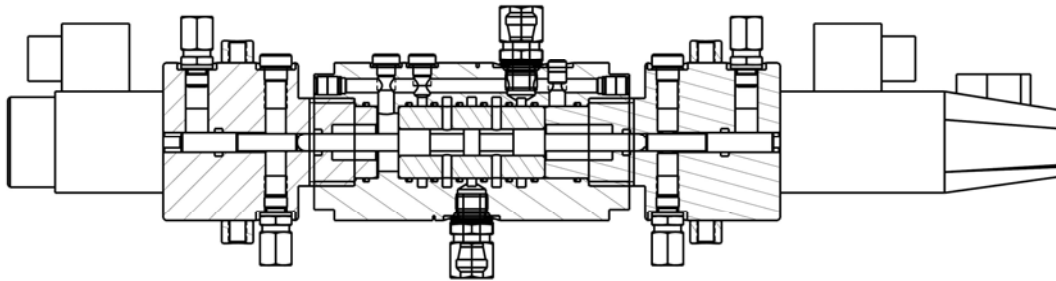

**Figure 3:** Cross section of the functional prototype of a proportional 4/3 directional sliding control valve

In the main part of our specimen – functional prototype of proportional 4/3 directional control valve sleeve and spool are simple in geometry and can thus be indeed easily changed (Fig. 4). We can manufacture these key-parts rather easily and in inexpensive way and thus test different materials, also those more expensive and those difficult to produce in more complex shapes, for example ceramics.

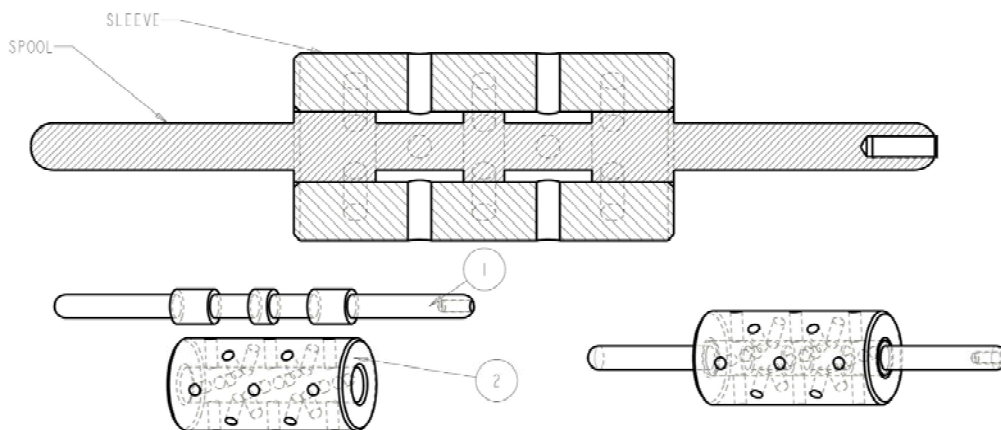

**Figure 4:** Main parts of the specimen: 1) spool and 2) sleeve

## 2.4 Testing procedure

In the real-scale life tests, loading cycles can be varied with pressure and flow to achieve different working regimes. The pressure can be changed up to 150 bar and flow up to 30l/min. As mentioned before, materials of studied parts can also be changed, both, the spool and the sleeve. Fluid temperature and fluid flow through specimen and spool stroke can be controlled; being varied or constant, depending on the testing parameters. Figure 5 briefly introduces the testing parameters and time cycle procedure for the selected system with the proportional 4/3 directional control sliding valve.

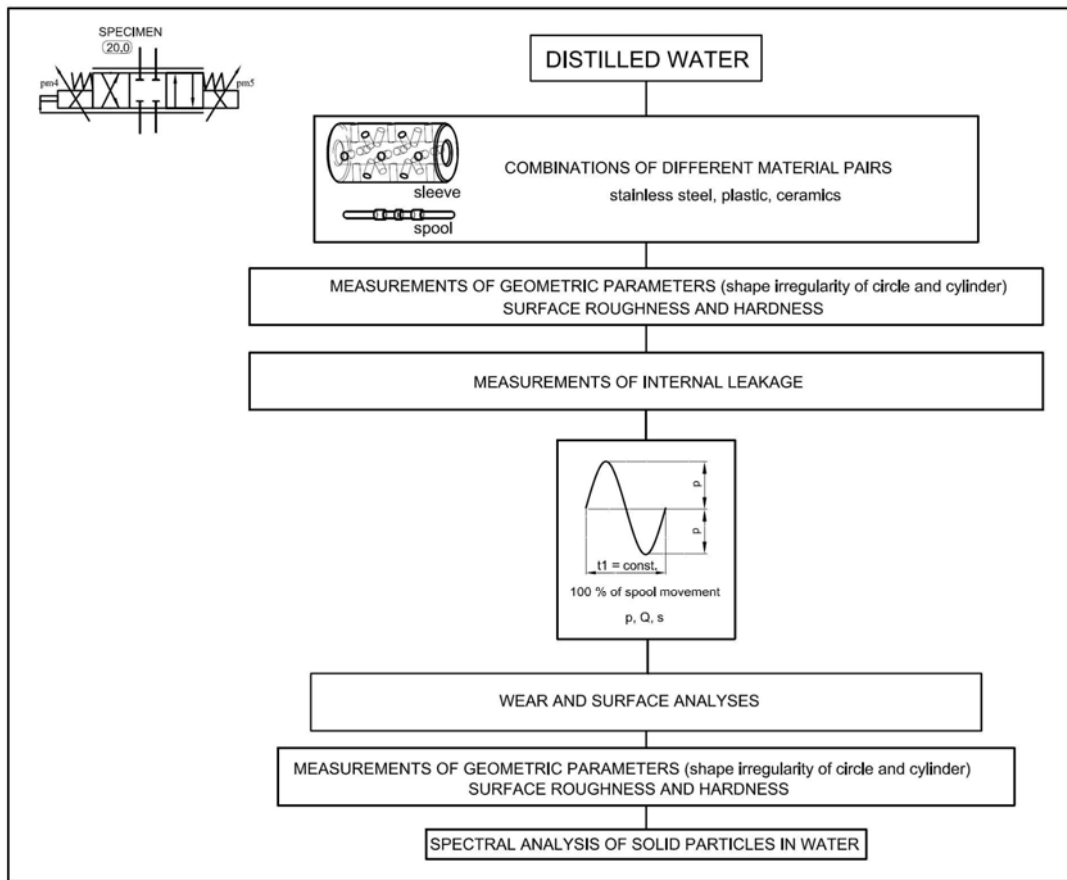

**Figure 5:** Course of life-time measurement on the main test rig

Before and after tests the geometric parameters of the spool and sleeve (shape irregularity of circle and cylinder) need to be measured and analyzed. Also, measurements of surface roughness and surface hardness are made. After the tests, the parts are dismantled and checked for wear loss, as well as the surfaces need to be analyzed to determine the wear mechanisms. Sometimes, the amount of solid particles in the system – or produced by the system - can also be of interest and this can be done on-line or after the test is finished.

Internal leakage can also be measured. The directional control valve is set in the neutral position (all ports blocked) and a pressure is assured by alternating on each port (P, A and B). After pressurizing each single port, the leakage is measured on the other three ports and sum them together.

The test rig was designed in way, to allow runs of different types of tests. They can be long-term tests to study the performance during longer periods and consequences of wear of the parts, primarily investigating the wear mechanisms by subsequent surface analyses, leakage, formation of wear debris, etc. However, short-term experiments can also be performed. Primarily, the dynamic response and effects of different geometrical and fluid characteristics is anticipated for these type of test runs. Namely, the majority of hydraulic systems are subjected to fast dynamic changes of flow and consequently pressure. The pressure responses of the test rig during gradual changes of hydraulic fluid flow can be measured. In this case we can use a known mass (Fig. 1, pos. 24.1) instead of the double acting through-rod hydraulic cylinder (Fig. 1, pos. 124.1). Comparison of the pressure / flow response of the specimen (proportional 4/3 directional control valve) at outlet port A and B (Fig. 1, pos. 20) with change of spool position and change of electrical current on the proportional solenoids (Fig. 1, pos. 26.1 and 28.1) can be performed.

### **3. Tribological tests of various material pairs**

#### **3.1 Experimental**

In order to investigate the change in hydraulic parameters, in particular wear resistance and useful life in selected hydraulic tests for different possible material combinations, model tribological tests were performed to make an initial or preliminary selection. Generally, stainless steel (SS) is the most typical and inexpensive material already used in several hydraulic parts and was thus reasonably the first-choice material. Other potential groups of materials include ceramics and polymers. Since ceramic materials are very costly and also have a low fracture toughness, they were not considered as the most suitable materials for the real-scale tests through which we would like to compare materials in the later stages of this research. Therefore, they were not included as the “studied” material (disk) in the first screening tribological tests; however, a ceramic was used at least as a counter-material, i.e. pin, which should also give us some indication of the tribological properties of the selected couples. Different commercially available polymeric materials were also considered. We selected those that can be used in water for a longer time-span [14 - 16] and gave some promising tribological results in the past, and which are also easily commercially available and suggested by world-wide



known producers. Thus, we selected two different types of materials from two groups of polymeric materials, i.e. polyetheretherketone (PEEK) and polyimide (PI). A commercially available PEEK (Victrex Europa GmbH, Germany) containing 30 % of carbon (CA30) and 30 % of glass (GL) fibers were used. Polyimides (Vespel) from Dupont<sup>TM</sup> without any addition (SP1) and containing 15% of graphite fibres were also tested. Pin materials were SS (X105CrMo17), obtained from Aubert&Duval and hardened to 55 Hrc, and alumina ceramic balls (99.7 % purity, 10 mm diameter) from Hightech Ceram. In total, 4 types of polymeric materials and stainless steel were selected as disc materials, while pins were of the same stainless steel and alumina ceramics. Table 1 presents the selected combinations.

**Table 1:** Material pairs used in preliminary tribological tests

Disc material	Pin 1	Pin 2
PEEK 30% glass (GL30)	Stainless steel (SS)	Alumina (Al <sub>2</sub> O <sub>3</sub> )
PEEK 30% graphite (CA30)	Stainless steel (SS)	Alumina (Al <sub>2</sub> O <sub>3</sub> )
PI no addition (SP1)	Stainless steel (SS)	Alumina (Al <sub>2</sub> O <sub>3</sub> )
PI 15% graphite (SP21)	Stainless steel (SS)	Alumina (Al <sub>2</sub> O <sub>3</sub> )
Stainless steel (SS)	Stainless steel (SS)	Alumina (Al <sub>2</sub> O <sub>3</sub> )

Tests were performed in a pin-on-disc apparatus (CSEM, Switzerland) with uni-directional sliding between the disc and the pin, see Figure 6. The relative sliding velocity was 0.1 m/s and a load of 1N was applied (Fig. 7), which corresponded to 40-70 MPa of initial contact pressure, depending on the material pair. In the open literature [14 - 16], data are available for some selected polymeric materials at lower pressures, but our goal was to investigate the higher-end load-region of those materials. Tests were run for 370 m of total sliding distance. All the tests were performed in a cup with distilled water at around 21°C, i.e. at room temperature conditions. These conditions correspond to a boundary lubrication regime, where hydrodynamic effects are negligible and the tribological performance depends primarily on surface and interface phenomena. Friction was monitored during the test and wear loss of the disc materials was subsequently calculated. The first empirical friction and wear results are presented in Figures 8 and 9, respectively. At present, detailed surface analyses, which would allow determination of wear and friction mechanisms and confident interpretation of the results, are still in progress.



**Figure 6:** Pin-on-Disc wear tester (CSEM)

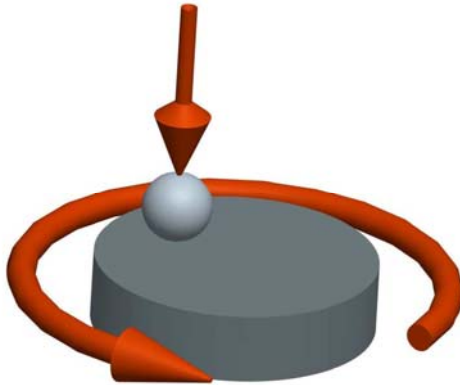

**Figure 7:** Functional principle of tribological pin-on-disk tests, lubricant: distilled water

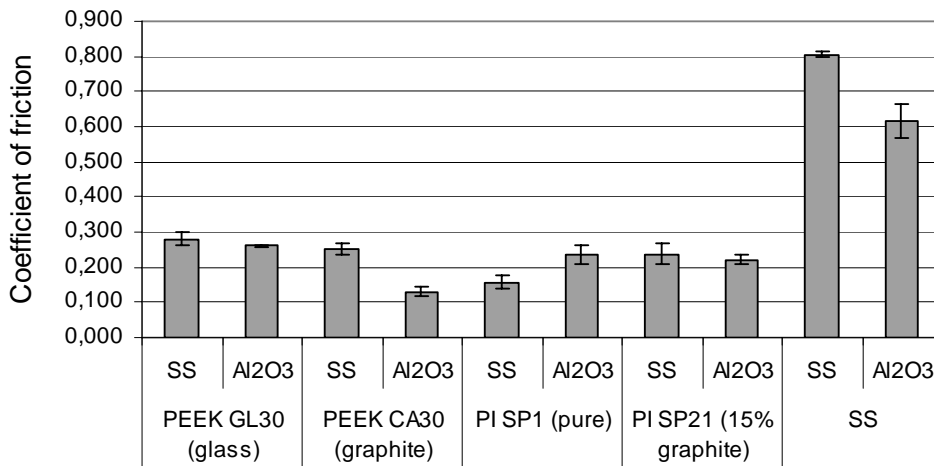

**Figure 8:** Coefficient of friction for selected material pairs (disc against two pin materials is shown)

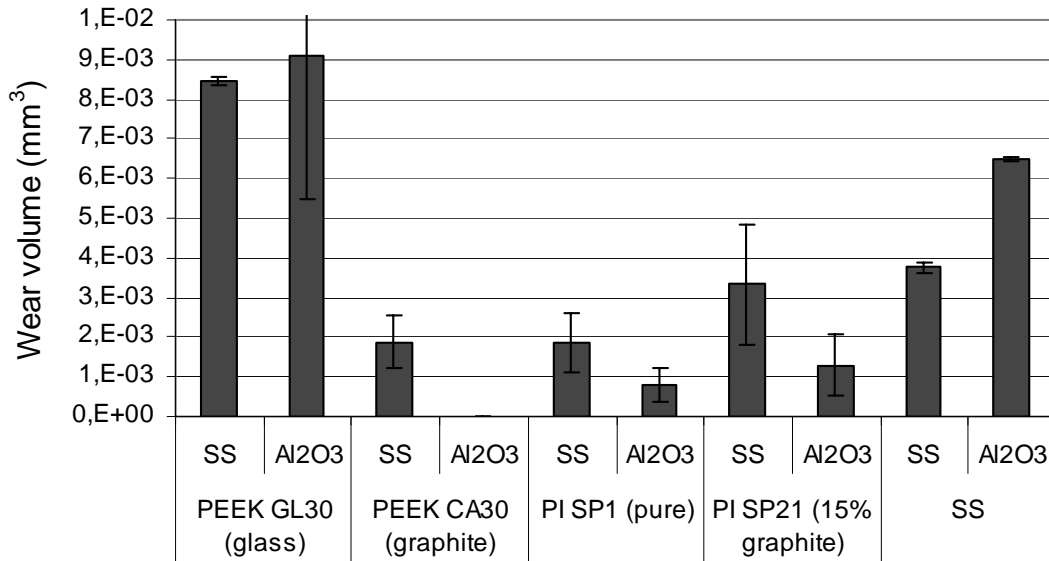

**Figure 9:** Wear loss for selected material pairs (disc against two pin materials is shown)

Compared to polymeric materials, significantly higher friction values were measured in contacts with SS discs, which were in the range of 0.6-0.8. Other friction data show friction values between 0.13 and 0.28, which is 2-3 times less than with SS discs. With the exception of pure polyimide (SP1), with all other polymer discs, contacts with alumina pins resulted in lower friction than against SS pins. However, these differences were not very high. Nevertheless, it is to be noticed that friction in the polyimide SP1 / SS contact resulted in the second lowest friction – about 0.16. This is important, because the polymeric material contain no additional components and is thus simpler and cheaper. Moreover, the SS pin is also the most preferred counter-material from a practical point of view. The lowest friction in this study was, however, obtained with the PEEK CA30/Al<sub>2</sub>O<sub>3</sub> combination, where friction was about 0.13.

In accordance with friction the data, the wear of PEEK CA30 in contact with an alumina pin was so low that was not possible to measure it with the techniques we used (stylus tip measurement with a resolution of around 50 nm in the z-axis). Therefore, this contact combination seems to be clearly the most promising of all those tested in this study. Low wear against alumina pins was also measured in the SP1 and SP21 polyimide samples. PEEK CA30, PI SP1 and PI SP21 also provided reasonably low values of wear in contacts against stainless steel pins. On the other hand, discs of SS and PEEK GL30 always resulted in higher wear losses. This was particularly pronounced against alumina pins, which is the opposite behaviour compared to PEEK CA30, PI SP1 and PI SP21.

## 4. Recapitulation and conclusions

- A simple test rig for investigation of the tribological and hydraulic behaviour of a water hydraulics system was designed. The conditions, materials and geometry can be well-defined and controlled. The test rig allows for testing of several hydraulic, operational, dynamic and tribological properties of selected systems.
- We also made preliminary model tribological tests to investigate the adequacy of different material pairs for use in a proportional 4/3 directional (sliding type) control valve.
- The lowest friction was obtained for the PEEK CA30/Al<sub>2</sub>O<sub>3</sub> contact. Another interesting low-friction pair appeared to be PI SP1/SS because of its easily applicable and low-cost material combination.
- The lowest wear was obtained in the PEEK CA30/Al<sub>2</sub>O<sub>3</sub> contact, in accordance with the lowest friction found for this material pair.
- Detailed surface analyses are in progress and comparison with more materials is planned for the future to understand the wear and friction mechanisms.

## Acknowledgements

For full support of this research we are sincerely grateful to Prof. Dr. Jože Vižintin, Head of CTD.

The authors are sincerely grateful to Slovenian company Tajfun, the greatest producer of forestry machinery in Europe, for financial and technical support.

For financial support of this research we are sincerely grateful to Slovenian Research Agency.

The majority of the components of the oil test rig were donated by the leading producer of hydraulic components in Slovenia, Kladivar d.o.o. The authors are sincerely grateful for this support.

## References

- [1] M. Kalin, J. Vižintin, A comparison of the tribological behaviour of steel/steel, steel/DLC and DLC/DLC contact when lubricated with mineral and biodegradable oils. *Wear* 261 [1] (2006) 22-31.
- [2] J. Barriga, M. Kalin, K. Van Acker, K. Vercaemmen, A. Ortega, L. Leiaristi. Tribological performance of titanium doped and pure DLC coatings combined with a synthetic bio-lubricant. *Wear* 261 [1] (2006) 9-14.

- [3] Kalin, M., Vižintin, J., Vercammen, K., Arnšek, A., Barriga, J., Van Acker, K. Tribological performance of lubricated DLC coatings using biodegradable oils. *The coatings in Manufacturing Engineering* (2004) 457-465.
- [4] J. Barriga, M. Kalin, K. Van Acker, K. Vercammen, A. Ortega, L. Leiaristi. Tribological characterisation and validation of carbon based coatings combined with bio-lubricants. *Proceedings of the 11th Nordic Symposium on Tribology*. Norway, June 2004. Pg. 508-517.
- [5] M. Kalin, F. Majdič, J. Vižintin, J. Pezdirnik. Performance of axial piston pump using DLC-coated piston shoes and biodegradable oil. in: *The 12th Nordic Symposium on Tribology, Helsingor, Denmark, June 7-9, 2006*. Nordtrib 2006. (2006), 10 Pgs.
- [6] Nessie – Sauer Danfos: <http://nessie.danfoss.com/>
- [7] Tiefenbach Wasserhydraulik GmbH: <http://www.ft-tiefenbach.de/>
- [8] Water Hydraulics Lth: [www.waterhydraulics.co.uk](http://www.waterhydraulics.co.uk)
- [9] Hauhinco Maschinenfabrik G. Hausherr, Jochums GmbH & Co. KG: [www.hauhinco.de](http://www.hauhinco.de)
- [10] E. Trostmann: *WATER HYDRAULICS CONTROL TECHNOLOGY*; Lyngby 1996, Technical University of Denmark; ISBN: 0-8247-9680-2
- [11] Y. Huayong, J. Sujuan, G. Guofang, Z. Hua: Investigation on the tribological properties of new materials and its application in water hydraulic piston pump, SICFP'05, Linköping, Sweden, 2005
- [12] J. Pezdirnik, F. Majdič, *Transient Phenomena in Gradual Changes of Hydraulic Fluid Flow*, 5. IFK, Aachen, 2006,
- [13] J. Pezdirnik: *Prehodni pojavi pri hidravličnih napravah v železarstvu (Transient Phenomena in Ironworks Hydraulic Systems)*, M. Sc. Thesis, Faculty of Mechanical Engineering, Ljubljana 1984
- [14] Y. Yamamoto, T. Takashima, Friction and wear of water lubricated PEEK and PPS sliding contacts, *Wear* 253 (2002) 820-826.
- [15] Y. Yamamoto, T. Takashima, Friction and wear of water lubricated PEEK and PPS sliding contacts Part 2. Composites with carbon or glass fibre, *Wear* 253 (2002) 820-826.
- [16] J.P. Davim, N. Marques, A.M. Baptista, Effect of carbon fibre reinforcement in the frictional behaviour of Peek in a water lubricated environment, *Wear* 251 (2001) 1100-1104.