

Robotic Hand Changer

Model **SWR**

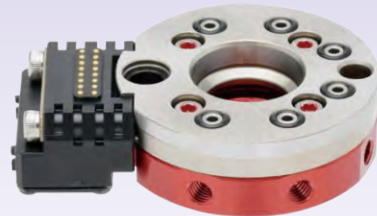

PAT.

Smaller, Lighter, and Stronger!!

Payload : 3kg, 7kg, 12kg, 25kg, 50kg, 75kg, 120kg, 230kg

Repeatability : 3 μ m High Rigidity : Zero Backlash

High Durability : More than 2 Million Cycles

High-accuracy Robotic Hand Changer enables multiple functions of robots and setup time reduction.

It enhances the productivity of automated production line.

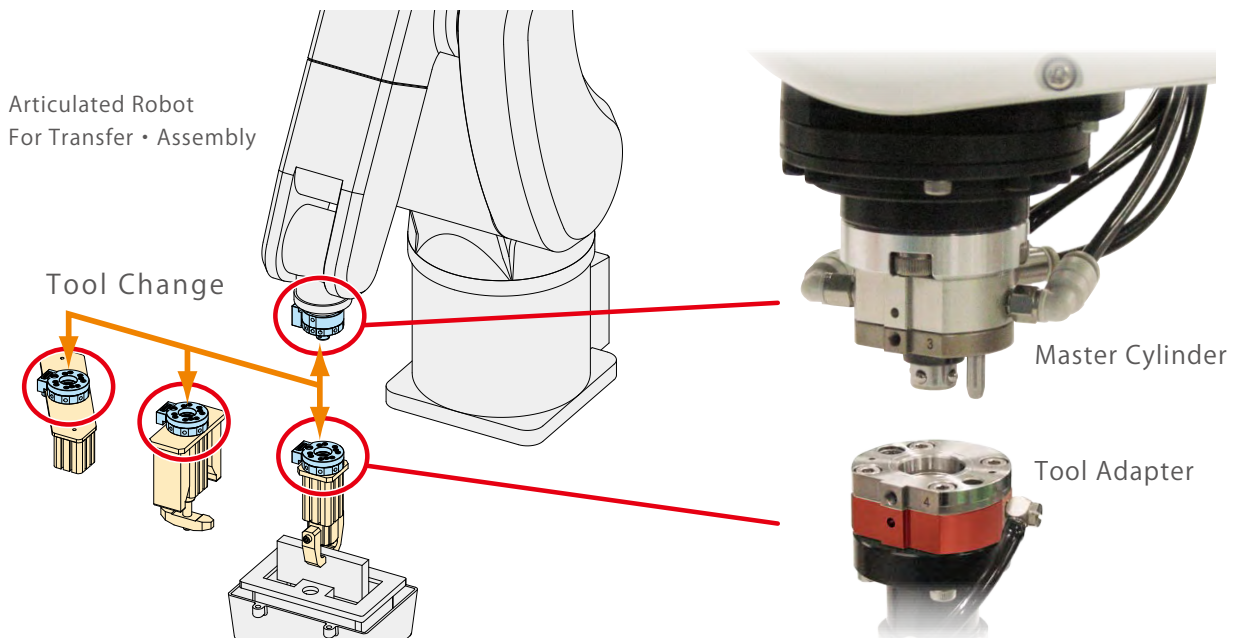

Application Examples

One robot performs multiple operations.

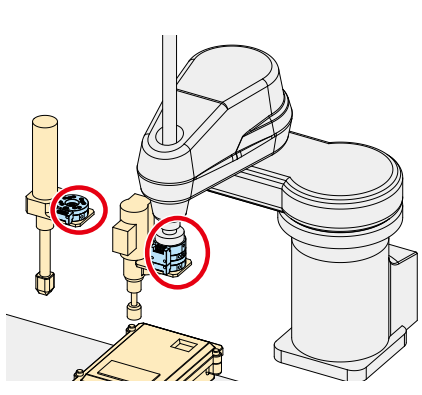

SCARA Robot
For Nut Runner Tool Change

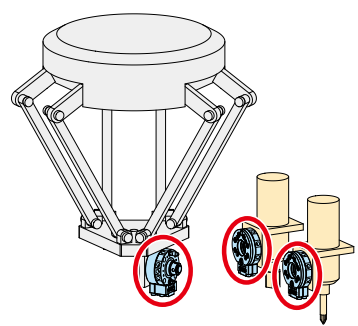

Parallel Link Robot
For Screw Tightening

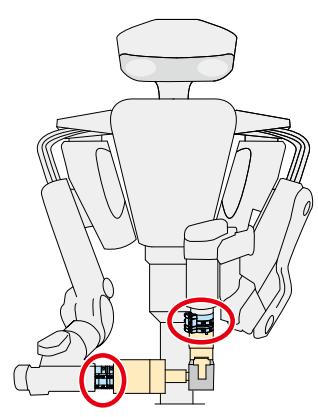

Humanoid Robot
For Assembly

- Locating + Clamp
- Locating
- Hand · Clamp
- Support
- Valve · Coupler
- Cautions · Others

Robotic Hand Changer

SWR Payload 3kg ~ 360kg
SWR010 Payload 0.5kg ~ 1kg

Manual Robotic Hand Changer
SXR

Pneumatic Location Clamp
SWT

Compact Pneumatic Location Clamp
SWQ

High-Power Pneumatic Pallet Clamp
WVS

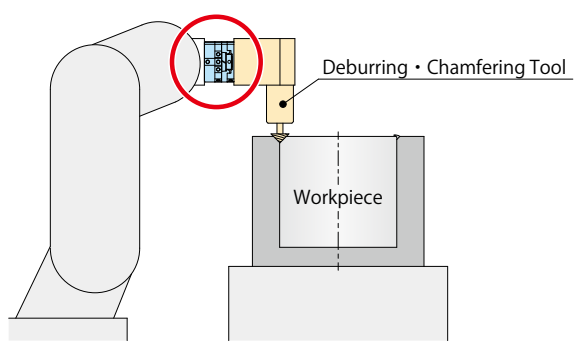

For Changing
Deburring and Machining Tools

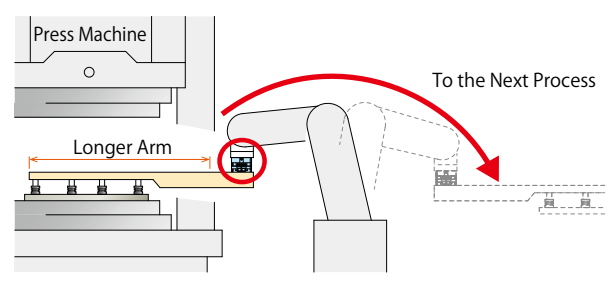

For Changing Transfer Robot Arms of
Automatic Line of Press Machines

High Accurate Repeatability

Repeatability : 3 μm
High-accuracy locating with dual contact by the taper sleeve. It enables high accurate repeatability.

Prevents Core Deflection and Chattering

No clearance or backlash with dual contact by the taper sleeve. It prevents core deflection and chattering due to the work load, and enhances productivity.

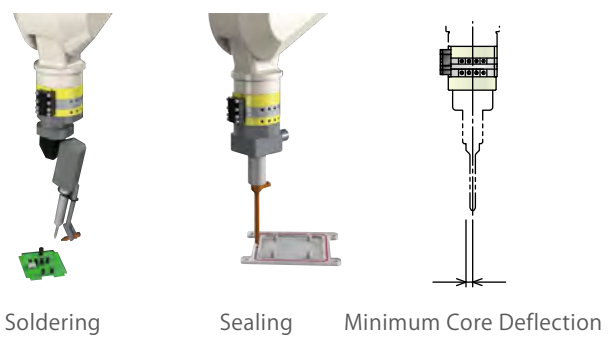

Minimum deflection of the tool end enables accuracy process.

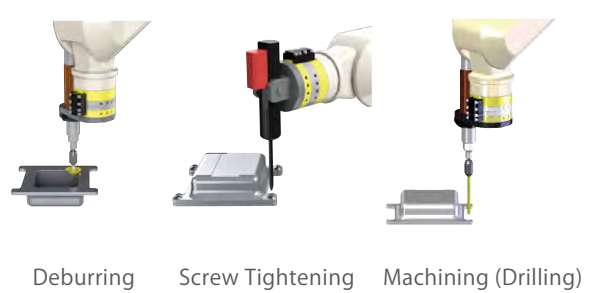

Suitable for the work which generates high torque.

Features

Light • Compact

Suitable for robotic hands which are severe on weight limits. Light Weight yet Large Load Capacity!!

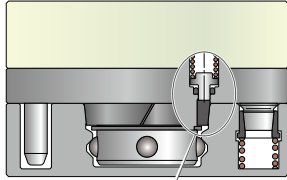

Close Contact

High Durability and Rigidity

Zero backlash when connecting and the durability is 2 million cycles. Even after 2 million cycles, repeatability 3 μm is maintained.

Zero backlash prevents core deflection and chattering.

No clearance or backlash with dual contact by the taper sleeve. It prevents core deflection and chattering due to the work load, and enhances productivity.

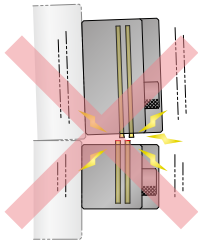

Prevents moment stops caused by electrode error.

"Zero" backlash of robotic hand changer minimizes the vibration of electrode and prevents noise and friction. Highly reliable electrode prevents moment stops caused by communication error.

The World's Only Exclusive Mechanism

Kosmek Robotic Hand Changer

General Robotic Hand Changer

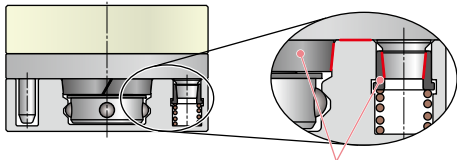

Dual Contact with Movable Taper Sleeve

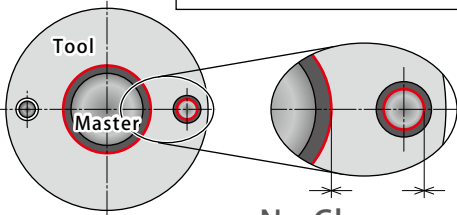
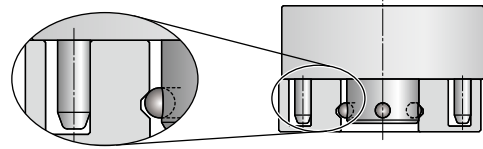

No Clearance (Zero Backlash)

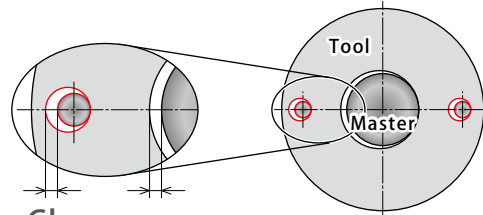

Clearance (Backlash)

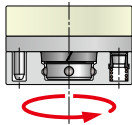

When torque acts in twisting direction

No Initial Displacement

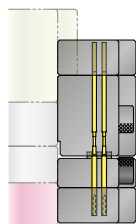
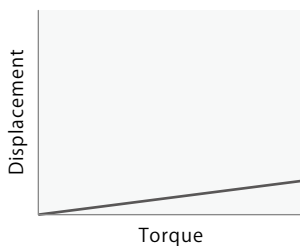

Zero Backlash

Moment Stop Reduced

Initial Displacement

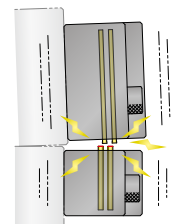
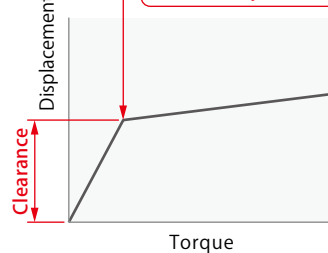

Backlash (Clearance) leads to noise • friction of a contact.

Moment Stop Occurs

Internal Spring

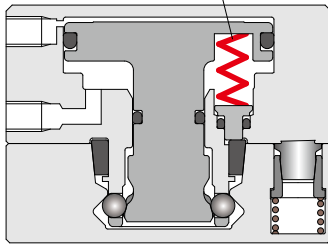

Self-Locking prevents tools from falling.

Even when pressure is at zero, self-locking function prevents tools from falling.

※ Usually it should be connected with spring force and air pressure.

Movable Taper Sleeve

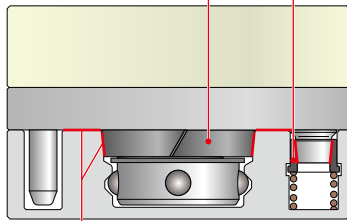

High Accuracy Repeatability 0.003mm

Repeatability is 3 μm.

Dual contact with movable taper sleeve enables high accuracy locating.

Only slight fluctuation at the end of tool allowing for precise operation.

Dual Contact

Lift up (Detaching) function protects locating part.

When connecting, lift up function prevents damage of the locating function part (seat surface and taper surface). When disconnecting, the piston rod detaches tool adaptor preventing moment stop caused by adhesion and galling.

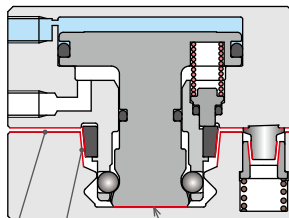

Seat Surface
Taper Surface
Lift Up with the End of Piston Rod (Detaching)

Kosmek Robotic Hand Changer

No Backlash on Changer Part

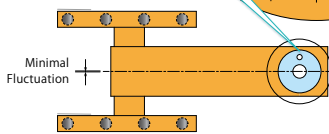

With 0.003mm Repeatability
Fluctuation on the Tip **0.05mm or less** ※

※Reference fluctuation value when the arm length =500mm with dimension conditions of SWR0250.
The result may differ depending on dimensions of a changer. Excluding displacement caused by load.

General Changer

Backlash on Changer Part

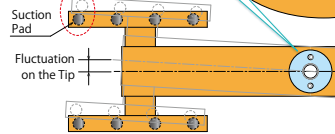

Ex.) Repeatability = ±0.015mm
Fluctuation on the Tip **0.5mm or less** ※

Minimal Fluctuation even with Longer Arm

With 3 μm repeatability, it minimizes fluctuation on the long arm tip, and prevents workpiece gripping errors or interference caused by displacement when transferring.

A Variety of Electrode/Air Joint Options

We offer a wide variety of options to meet your needs.



Locating + Clamp

Locating

Hand - Clamp

Support

Valve - Coupler

Cautions - Others

Robotic Hand Changer

SWR
Payload
3kg ~ 360kg

SWR010
Payload
0.5kg ~ 1kg

Manual Robotic Hand Changer

SXR

Pneumatic Location Clamp

SWT

Compact Pneumatic Location Clamp

SWQ

High-Power Pneumatic Pallet Clamp

VVS

Cross Section

High Accuracy / High Rigidity / Long Operational Life

High Accuracy
Marginal error is absorbed by the taper sleeve. The clearance between the master cylinder, taper sleeve and tool adaptor is eliminated. This enables the repeated locating accuracy and stabilized clamping force.

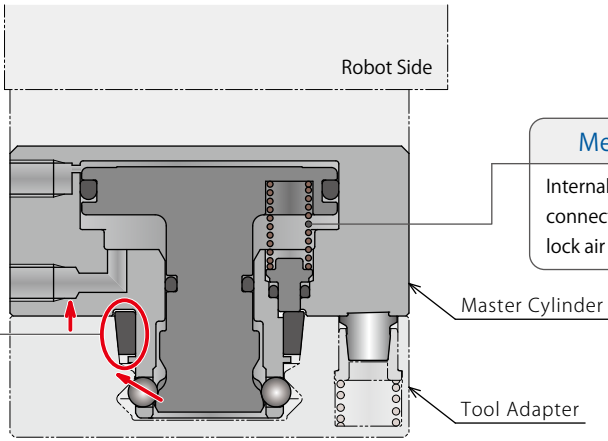

Mechanical Lock
Internal spring maintains the connected state even when lock air supply is stopped.

High Rigidity
Clearance is eliminated when the master cylinder and tool adapter are connected. This enables high rigidity.

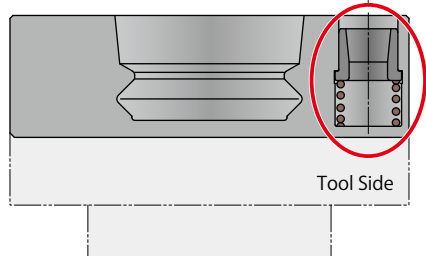

Long Operational Life
Wear is absorbed by the movable taper sleeve.

Action Description

Before Connected (Released State)

Lifted State (Detached State)

Connected State (Locked State)

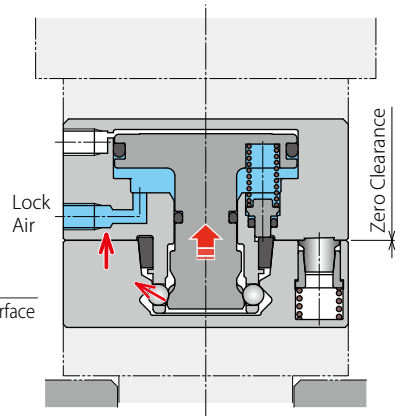
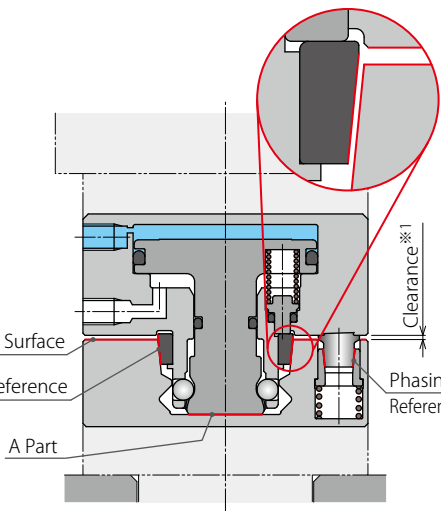
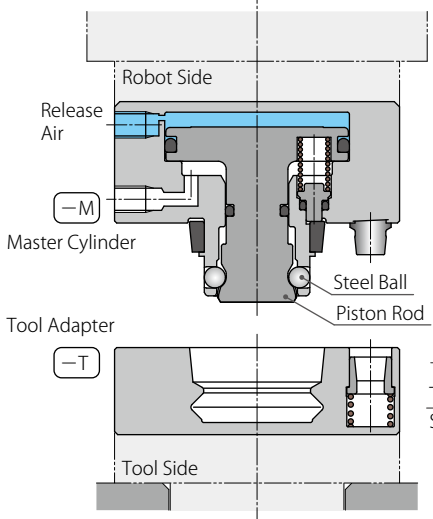

Supply air to the release side. The piston rod is pushed down with thrust force caused by release air. At this time the steel balls are free to move (set inside).

When the master cylinder is lowered and stopped at the amount of lift ~+0.5mm, it is in setting state. At this time there is a moderate gap at taper reference surface and seating surface. It prevents locating mechanism part from damage. When detached, the piston pushes out A part to prevent moment stop caused by fixation or galling.

※1. Refer to the caution "Most Suitable Gap b/w Master Cylinder and Tool Adapter Just Before Connection (When Setting)" on P.79.

Stop the release air pressure and supply air to the lock port. The piston rod will be pulled up with piston thrust and an internal spring, and the tool adapter will be pulled to the seating surface by the steel balls. When the tool adapter is pulled, the taper reference surface and phasing taper sleeve are centered in a reference axis (body), and locating is completed.

Air Port Option (Joint Option)

When the master cylinder and tool adapter are connected, the air port is at the connected state. At this time, it is able to supply air from the robot side to the tool side. Air port can be used for the operation of the actuator (positive pressure) and the suction pad (negative pressure).

The number of air ports depends on the option. Please refer to the specifications for further information.

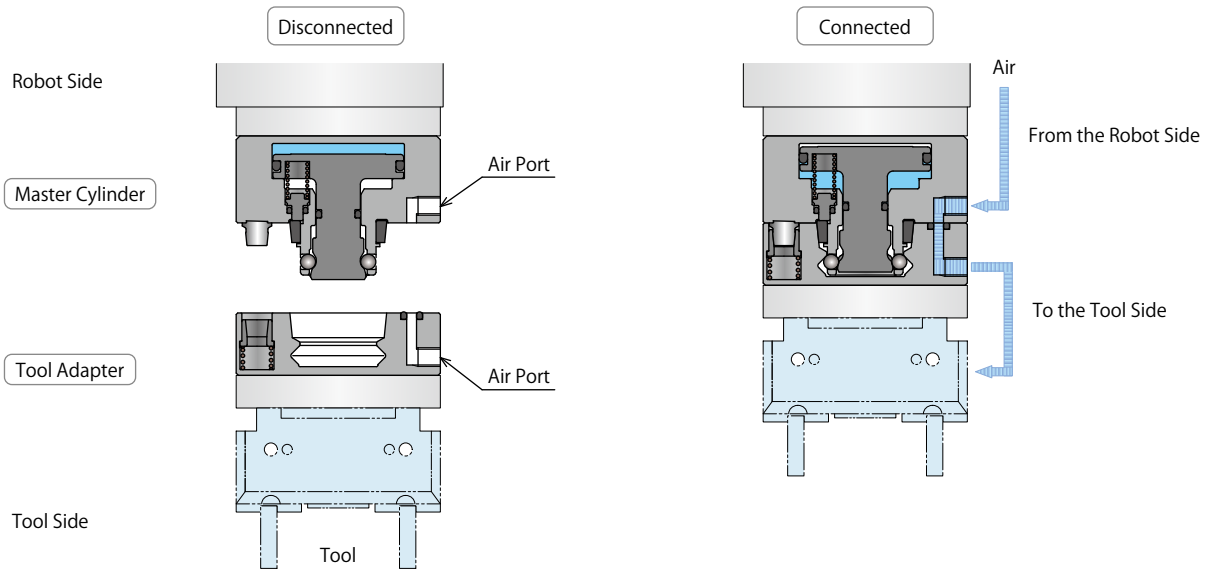

Selectable from two air port joint options. ※ Refer to P.68 for further information.

Electrode Option

When the master cylinder and tool adapter are connected, the electrode (option) is in the connected state.

At this time, it is able to transmit electrical signal and supply electricity between the robot and tool.

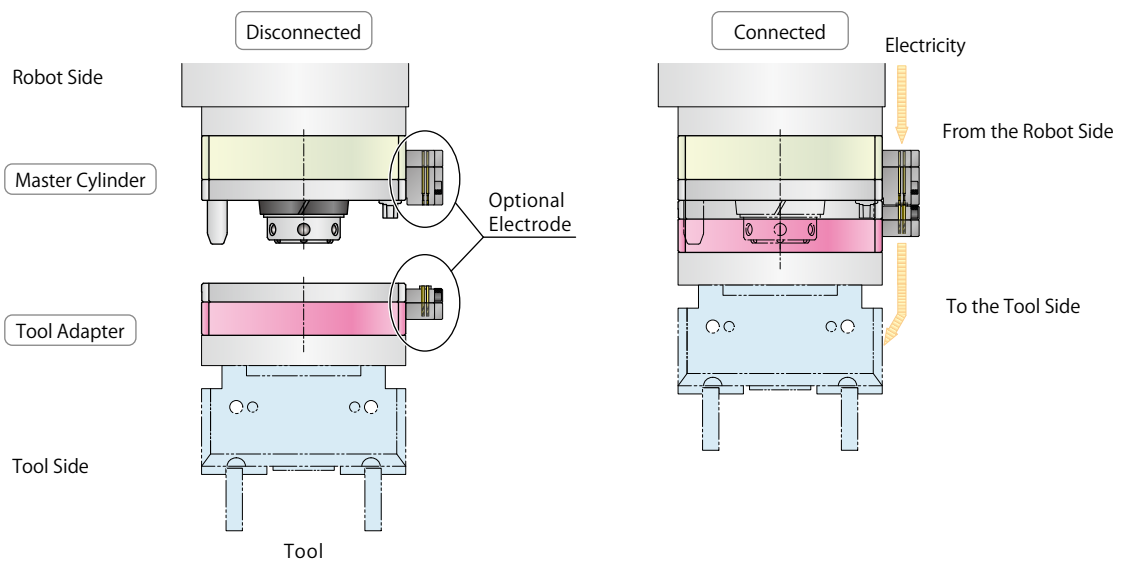

- Locating + Clamp
- Locating
- Hand · Clamp
- Support
- Valve · Coupler
- Cautions · Others

Robotic Hand Changer

SWR
Payload
3kg ~ 360kg

SWR010
Payload
0.5kg ~ 1kg

Manual Robotic
Hand Changer
SXR

Pneumatic
Location Clamp
SWT

Compact Pneumatic
Location Clamp
SWQ

High-Power Pneumatic
Pallet Clamp
WVS

● Model No. Indication



Master Cylinder (Robot Side)

Payload 3kg ※ Refer to P.69 for SWRY0010 (with 6 air ports).

SWR 003 0 - M - J

1
2
4

Payload 7kg ~ 75kg

SWR 007
012
025
050
075

0 - M F - J -

1
2
3
4
5

Payload 120kg ~ 230kg (360kg)

SWR 120
230

0 - M AF - J -

1
2
3
4
5

Payload 0.5 ~ 1kg

SWR0010-M- Refer to P.83 for further information.

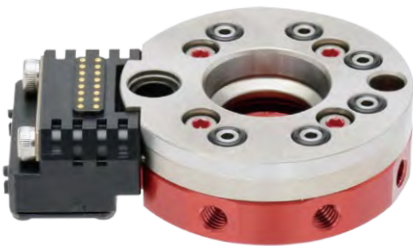

Tool Adapter (Tool Side)

Payload 3kg ~ 75kg ※ Refer to P.69 for SWRY0010 (with 6 air ports).

SWR 003
007
012
025
050
075

0 - T - J

1
2
4

Payload 120kg ~ 230kg (360kg)

SWR 120
230

0 - T - J -

1
2
4
5

Payload 0.5 ~ 1kg

SWR0010-T- Refer to P.83 for further information.

1 Payload ※ Payload at 0.5MPa

003 :	3 kg	Refer to P.83 for 001 : 0.5 ~ 1 kg Payload model.
007 :	7 kg	
012 :	12 kg	
025 :	25 kg	
050 :	50 kg	
075 :	75 kg	
120 :	120 kg	
230 :	230 kg	

2 Design No.

0 : Revision Number

3 Port Option ※ The port option is applicable to the master cylinder only.

- Blank** : No Port
(Only **Blank** can be chosen for SWR0030.)
- F** : Standard (with Seat Check Port)
- A** : With Air Blow Port
- AF** : With Air Blow Port + Seat Check Port
(Only **AF** option can be chosen for SWR1200/SWR2300.)

3 Port Option Symbol	● = Available Option							
	3kg	7kg	12kg	25kg	50kg	75kg	120kg	230kg
Blank	●							
F		●	●	●	●	●		
A		●	●	●	●	●		
AF							●	●

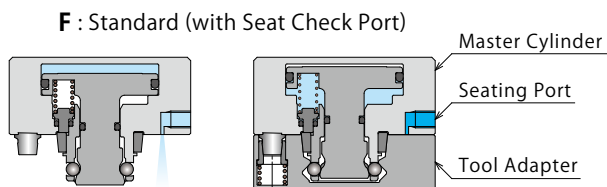

Action confirmation can be conducted by detecting differential pressure with the air catch sensor.

※Refer to P.67 for further information.

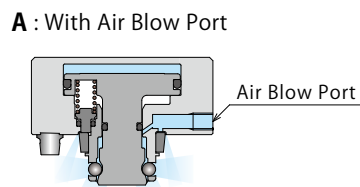

Locating mechanism part can be cleaned with the air blow.

※Refer to P.67 for further information.

4 External Option Symbols (Electrode/Air Joint)

Refer to P.23 ~ P.24 for model number symbols.



5 Joint Option (Air Port Part) ※ Refer to P.68 for detail of the joint option.

- Blank** : No Check Valve (Standard)
- S** : With Check Valve

※ Option Symbol of Tool Adapter Side : Specify with "-S" only when selecting SWR1200 / SWR2300 with check valve. Since the tool adapter of SWR0070 / SWR0750 is shared, the symbol is "**Blank**" regardless of the use of check valve.

5 Joint Option Symbol	● = Available Option							
	3kg	7kg	12kg	25kg	50kg	75kg	120kg	230kg
No Check Valve (Standard)	Blank	Blank	●	●	●	●	●	●
With Check Valve	S	Blank		●	●	●	●	
	S	S					●	●



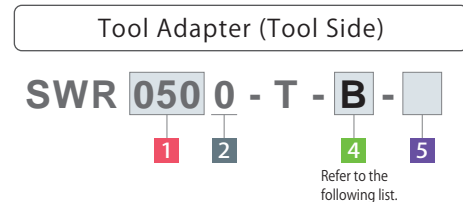
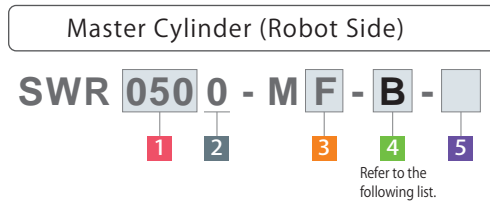











Model No. Indication



4 External Option Symbols (Electrode/Air Joint) ^{※1}

Please select from the list below. ※ (Ex.) Solder Terminal 15 poles : **B**

• Electrode

Rated Voltage	Rated Current	External Options (Detail Page)	Number of Poles	4 Option Symbol	●● = Available Option										
					3kg SWR 0030	7kg SWR 0070	12kg SWR 0120	25kg SWR 0250	50kg SWR 0500	75kg SWR 0750	120kg SWR 1200	230kg SWR 2300			
-	-	Standard : No External Attachment	-	Blank	●	●	●	●	●	●	●	●	●		
DC24V	2A ^{※2} /1A	Resin Connector P.37 	16 Poles	J	●	●	●	●	●	●	●	●	●		
		Solder Terminal P.41 	15 Poles 30 Poles (2 Sets of 15 Poles)	B	●	●	●	●	●	●	●	●	●		
	3A ^{※2}	Solder Terminal with Cable P.43 	Cable 1m	15 Poles	C01	●	●	●	●	●	●	●	●		
			Cable 2m	15 Poles	C02	●	●	●	●	●	●	●	●		
		Simple Waterproof Electrode Only when connected : IP54 P.47 	Cable 1m	30 Poles (2 Sets of 15 Poles)	C01C01 / C012	●	●	●	●	●	●	●	●		
			Cable 2m	30 Poles (2 Sets of 15 Poles)	C02C02 / C022	●	●	●	●	●	●	●	●		
	D-sub Connector P.51 	15 Poles	D				●	●	●	●	●	●			
	Circular Connector (Connector Based on JIS C 5432) P.52 	15 Poles	G				●	●	●	●	●	●			
	AC200V DC200V	5A ^{※2}	Compact Electric Power Transmission Option P.53 	4 Poles	K	●	●	●	●	●	●	●	※3	●	
				4 Poles + Electrode J	JK / JK2		●	●	●	●	●	●	●	※3	●
4 Poles + Electrode B				BK / BK2		●	●	●	●	●	●	●	●	※3	●
4 Poles + Electrode C01				C01K / C01K2		●	●	●	●	●	●	●	●	※3	●
4 Poles + Electrode C02		C02K / C02K2		●	●	●	●	●	●	●	●	●	※3	●	
Power Transmission Option (Connector Based on MIL-DTL-5015) P.57L 	8 Poles	E				●	●	●	●	●	●	●			
13A ^{※2}	High Current Transmission Option (Connector Based on MIL-DTL-5015) P.57R 	10 Poles	H				●	●	●	●	●	●			
for Power AC/DC240V for Signal DC24V	for Power 20A for Signal 3A	Servo Electrode P.59 	6 Poles for Power Supply 17 Poles for Signal + 1 Pole for Functional Ground	Cable 1m F01 Cable 2m F02 Cable 5m F05				●	●	●	●	●	●		
Noncontact Waterproof Electrode IP67 Compact Model P.59 	Number of Signals : 4	NPN	W	●	●	●	●	●	●	●	●	※3	●		
		PNP	WX ^{※4}	●	●	●	●	●	●	●	●	●	※3	●	
Noncontact Waterproof Electrode IP67 P.61 	Number of Signals : 12	NPN	Cable 2m ^{※Tool Adapter Side : 1m} V				●	●	●	●	●	●			
			Cable 5m V5				●	●	●	●	●	●	●		
		PNP	Cable 2m VX ^{※5}					●	●	●	●	●	●		
			Cable 5m VX5 ^{※5}					●	●	●	●	●	●		
Ground Electrode Rated Capacity 500A (Activity Ratio 50%) P.62 	1 Pole	T				●	●	●	●	●	●				
Ethernet Electrode P.63 	4 Poles	L				●	●	●	●	●	●				

※ Refer to P.24 "General Cautions for Selecting External Options".

• Air Joint

Number of Ports (Min. Passage Area)	External Options (Detail Page)	Additional Electrodes	Option Symbol	●● = Available Option								
				3kg SWR 0030	7kg SWR 0070	12kg SWR 0120	25kg SWR 0250	50kg SWR 0500	75kg SWR 0750	120kg SWR 1200	230kg SWR 2300	
3 Ports (Equal to φ6×1 port Equal to φ2×2 port)	Air Joint (Able to extend electrodes J/B/C) P.64	None (Air Joint Only)	R	●	●	●	●	●	●	※3	※3	
		Electrode J	●JR / ●JR2		●	●	●	●	●	●	※3	※3
		Electrode B	●BR / ●BR2		●	●	●	●	●	●	※3	※3
		Electrode C01	●C01R / ●C01R2		●	●	●	●	●	●	※3	※3
		Electrode C02	●C02R / ●C02R2		●	●	●	●	●	●	※3	※3
4 Ports (Equal to φ 1.6)	Air Joint (Able to extend electrodes J/B/C) P.65	None (Air Joint Only)	P		●	●	●	●	●	※3	※3	
		Electrode J	●JP / ●JP2		●	●	●	●	●	●	※3	※3
		Electrode B	●BP / ●BP2		●	●	●	●	●	●	※3	※3
		Electrode C01	●C01P / ●C01P2		●	●	●	●	●	●	※3	※3
		Electrode C02	●C02P / ●C02P2		●	●	●	●	●	●	※3	※3
2 Ports (Equal to φ 4)	Air Joint P.66	None (Air Joint Only)	Q				●	●	●	※3	※3	

【 General Cautions for Selecting External Options 】

Difference between ● and ● is mounting positions of external options, because SWR0250 ~ SWR2300 have two mounting surfaces for external options. Refer to the following example of external option model number for further information.

- ※1. For the combination of external options, the symbols should be specified in alphabetical order. (Ex: 'JR2' and 'E', it is 'EJR2'.)
- ※2. For the electrode options, check the total current capacity and contact resistance shown in the specifications of each option.
- ※3. Please contact us for the options of SWR1200/SWR2300 marked with ※3.
- ※4. The option symbol 'WX' is only for master cylinder. The option symbol of the tool adapter is 'W' for both NPN/PNP.
- ※5. The option symbol 'VX/VX5' is only for master cylinder. The option symbol of the tool adapter is 'V' for both NPN/PNP.

Option Mounting Surface and External Option Model No. Example

SWR0030 / SWR0070 / SWR0120 has **Option Mounting Surface : 1 part**

Example : Solder Terminal 30 Poles (2 sets of 15 poles)

(Ex.) Model : SWR0070 - MF - **BB**

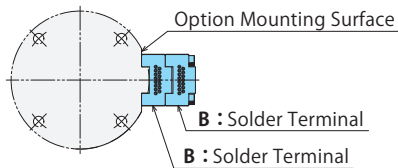

SWR0250 / SWR0500 / SWR0750 / SWR1200 / SWR2300 has **Option Mounting Surface : 2 parts**

- (Ex. 1) When selecting 'BB' for SWR0250~SWR2300, electrode 'B' is mounted on each the first and second option mounting surface.
- (Ex. 2) When selecting 'B2' for SWR0250~SWR2300, electrode 'B' is extended to electrode 'B' on the first option mounting surface.
- (Ex. 3) When selecting 'BK2' and 'B', the symbols should be specified in alphabetical order as '**B BK2**'. The arrangement is as follows : Electrode 'B' on the first option mounting surface, electrode 'BK2' ('B' extended to 'K') on the second option mounting surface.

(Ex.1) Model : SWR0250 - MF - **BB**
(Model no. example of ●)

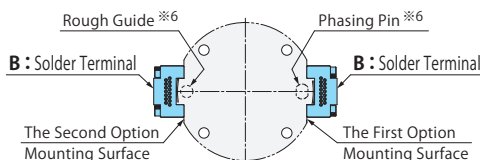

(Ex.2) Model : SWR0250 - MF - **B2**
(Model no. example of ●)

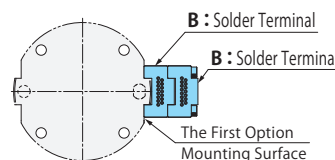

(Ex.3) Model : SWR0250 - MF - **B BK2**

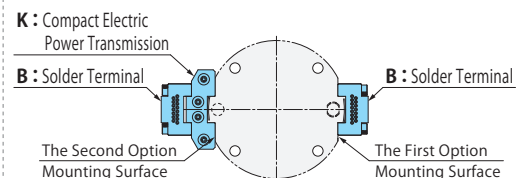

※6. Check the external dimensions on P.34 for option mounting surface of SWR2300.

Specifications

Model No.		SWR0030	SWRY0010	SWR0070	SWR0120	SWR0250	SWR0500	SWR0750	SWR1200	SWR2300	
Payload ^{※1}	at 0.5MPa	kg	3	7	12	25	50	75	120	230	
	at 0.7MPa	kg	-	-	-	-	-	-	-	360	
	at 1MPa	kg	6	12	20	45	90	140	200	-	
Repeatability	mm	0.003									
Lift Stroke (Detaching Stroke)	mm	0.8	0.8	0.8	1.0	1.0	1.0	1.0	1.0	1.0	
Cylinder Capacity	Lock	cm ³	0.64	1.50	2.38	6.08	14.38	22.98	38.44	89.54	
	Release	cm ³	0.72	1.72	2.69	6.68	15.39	25.45	42.76	100.73	
Operating Air Pressure	Max. Pressure	MPa	1.0	1.0						0.7	
	Min. Pressure	MPa	0.4	0.35						0.35	
	Withstanding Pressure	MPa	1.5	1.5						1.05	
Holding Force		Refer to P.26	Refer to P.70	Refer to P.26						Refer to P.26	
Lifting Force (Detaching Force)		Refer to P.26	Refer to P.70	Refer to P.26						Refer to P.26	
Allowable ^{※1}	Bending (at 0.5MPa)	N·m	5	14	27	74	194	380	725	1800	
	Bending (at 1.0MPa)	N·m	(10)	(25)	(45)	(135)	(350)	(700)	(1400)	-	
Static Moment	Twisting	N·m	15	12	23	45	100	175	300	700	
		N·m	15	12	23	45	100	175	300	700	
Max. Load ^{※2}	Bending (at 0.5MPa)	N·m	10	28	54	148	388	760	1450	3600	
	Bending (at 1.0MPa)	N·m	(20)	(50)	(90)	(270)	(700)	(1400)	(2800)	-	
Moment	Twisting	N·m	30	24	46	90	200	350	600	1400	
Operating Temperature	°C	0 ~ 70									
Usable Fluid		Dry Air									
Weight ^{※3}	Master Cylinder	g	70	85	180	250	500	1000	1650	3800	7100
	Tool Adapter	g	45	60	120	160	300	750	1100	2600	4800
Number of Air Ports ^{※4}	Thread Size ×	M3×0.5×2 Ports	M3×0.5×6 Ports	M5×0.8×6 Ports	M5×0.8×6 Ports	M5×0.8×6 Ports	M5×0.8×2 Ports				
	Number of Ports		※5				Rc1/8×4 Ports	Rc1/8×9 Ports	Rc1/4×9 Ports	Rc3/8×10 Ports	
Air Port Minimum Passage Area	5 Joint Option Blank	mm ²	1.1 (Equal to φ1.2)	1.1 (Equal to φ1.2)	2.0 (Equal to φ1.6)	2.0 (Equal to φ1.6)	2.0 (Equal to φ1.6)	7.1 (Equal to φ3.0)	7.1 (Equal to φ3.0)	63.6 (Equal to φ9.0)	63.6 (Equal to φ9.0)
	5 Joint Option S	mm ²	-	-	1.7 (Equal to φ1.5)	1.7 (Equal to φ1.5)	1.7 (Equal to φ1.5)	3.4 (Equal to φ2.1)	3.4 (Equal to φ2.1)	13.0 (Equal to φ4.1)	13.0 (Equal to φ4.1)
Electrode Option		Refer to P.37 ~ P.66									
Allowable Offset while Teaching		Refer to P.78									

Notes :

- ※1. Please consider both the payload and allowable static moment when selecting the product.
- ※2. The product must be used within Allowable Static Moment (※1). Using within Max. Load Moment will not fill the specifications.
- ※3. Weight of the body without external options.
- ※4. Refer to P.20 for air port use.
- ※5. We offer SWRY0010 with 6 air ports (see P.69) for those who require additional number of air ports for SWR0030.

Point The whole surface is a seating surface
High Rigidity Possible !!

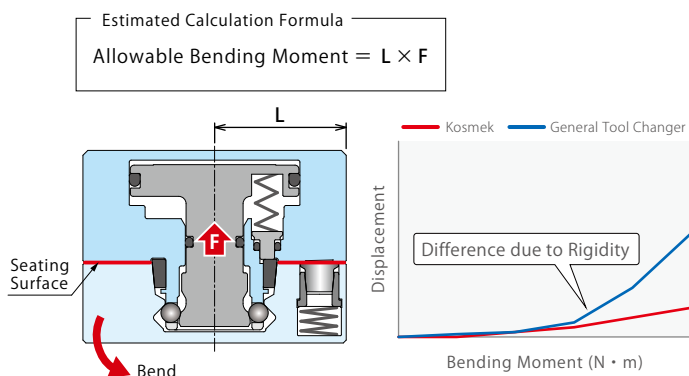

Point Kosmek Exclusive Mechanism
Zero Backlash !! Strong to Twist

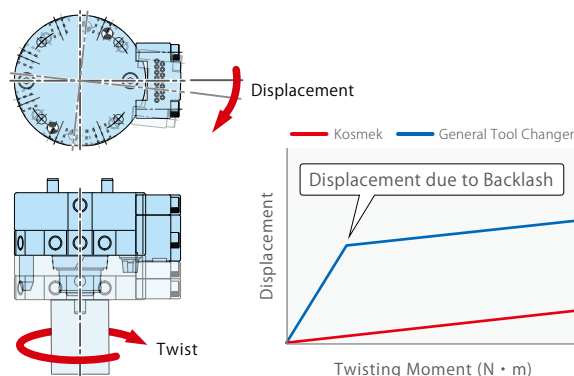

※ Refer to P.17 for further explanation.

● Holding Force Curve

Holding Force		SWR0030	SWRY0010	SWR0070	SWR0120	SWR0250	SWR0500	SWR0750	SWR1200	SWR2300
Holding Force	At 0MPa ^{※6}	kN	0.12	0.15	0.32	0.57	0.95	1.29	1.97	2.78
	At 0.35MPa	kN	–	0.68	1.14	2.31	4.44	6.87	9.84	19.56
	At 0.4MPa	kN	0.45	0.75	1.26	2.56	4.94	7.67	11.00	21.96
	At 0.5MPa	kN	0.50	0.90	1.50	3.05	5.94	9.26	13.33	27.72
	At 1MPa	kN	0.90	1.64	2.67	5.53	10.92	17.24	24.95	–

Note :

※6. It indicates holding force when air pressure is at 0MPa after connecting and may not fill the specification.

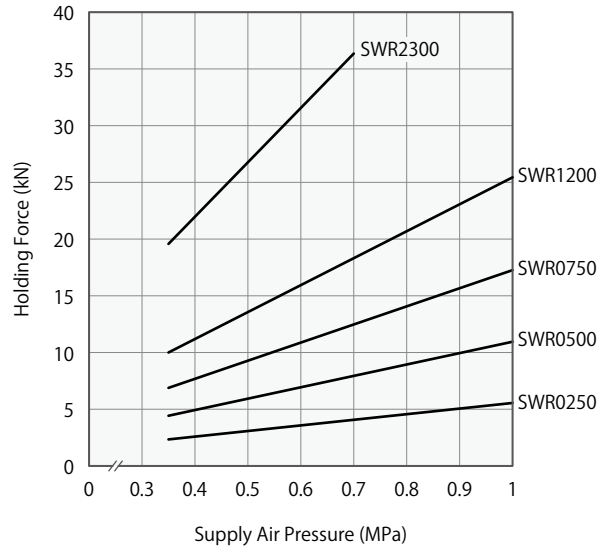
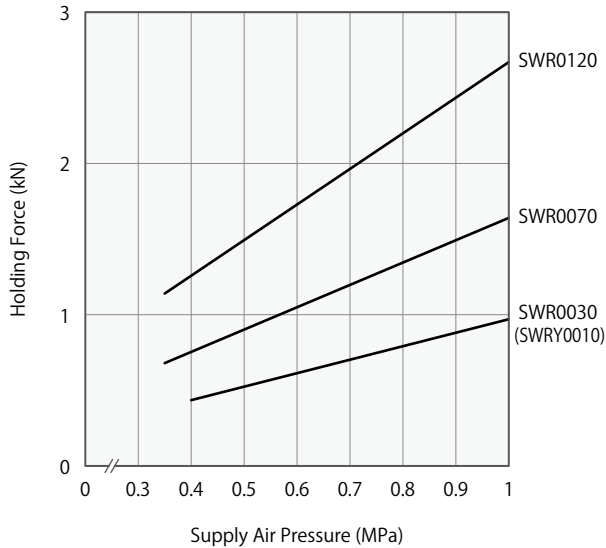

Note :

1. Tables and graphs shown are the relationship between supply air pressure (MPa) and holding force (kN).

● Lifting Force (Detaching Force)

Model No.		SWR0030	SWRY0010	SWR0070	SWR0120	SWR0250	SWR0500	SWR0750	SWR1200	SWR2300
Lifting Force (Detaching Force)	At 0.35MPa	kN	(0.03: at 0.4MPa)	0.11	0.16	0.38	0.77	1.45	2.22	4.53
	At 0.5MPa	kN	0.08	0.20	0.30	0.68	1.34	2.41	3.62	7.18
	At 1MPa	kN	0.23	0.51	0.78	1.66	3.27	5.59	8.28	–

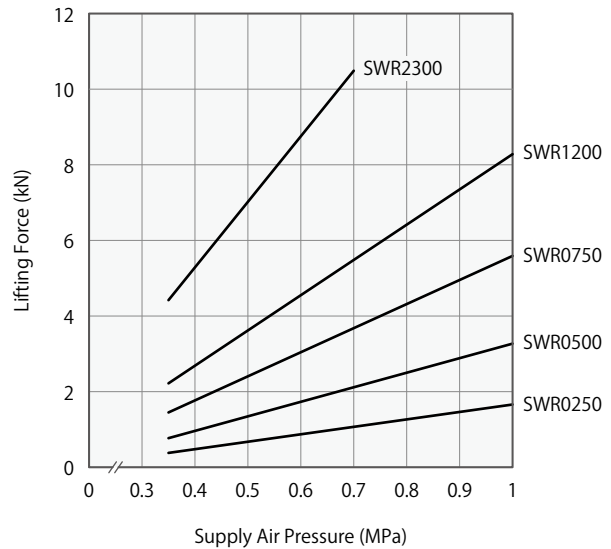
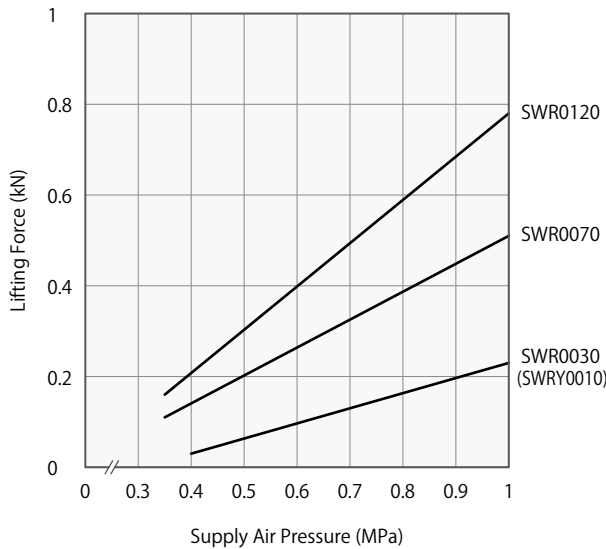

Note :

1. Tables and graphs shown are the relationship between supply air pressure (MPa) and lifting force (kN).

Locating + Clamp

Locating

Hand · Clamp

Support

Valve · Coupler

Cautions · Others

Robotic Hand Changer

SWR Payload 3kg ~ 360kg

SWR0010 Payload 0.5kg ~ 1kg

Manual Robotic Hand Changer

SXR

Pneumatic Location Clamp

SWT

Compact Pneumatic Location Clamp

SWQ

High-Power Pneumatic Pallet Clamp

WVS

External Dimensions (SWR0030)

※ This drawing shows the released state of SWR0030. Refer to P.71 for External Dimensions of SWRY0010.

Master Cylinder
SWR0030-M

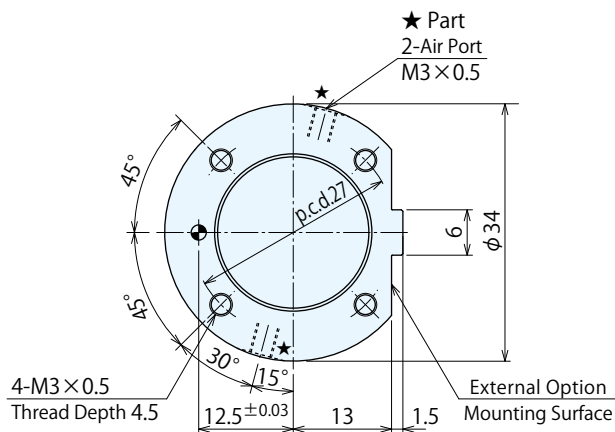
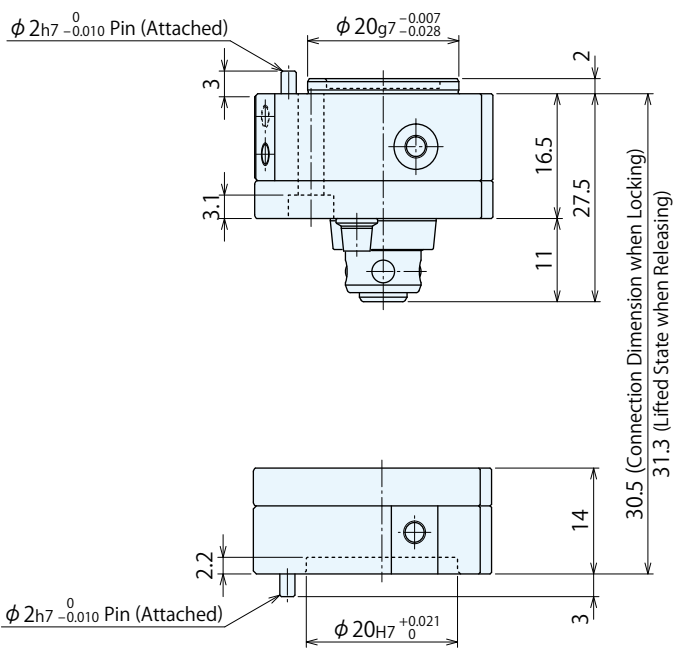
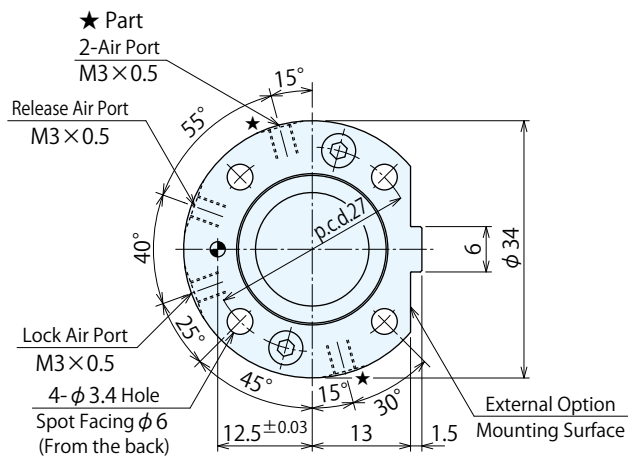

Tool Adapter **SWR0030-T**

External Dimensions (SWR0070)

※ This drawing shows the released state of SWR0070.

Master Cylinder (Standard)
SWR0070-M□

Master Cylinder (with Check Valve)
SWR0070-M□-S

※ The air port positions and **mounting dimensions are different** from those of the standard option.
Only the different dimensions are described below.

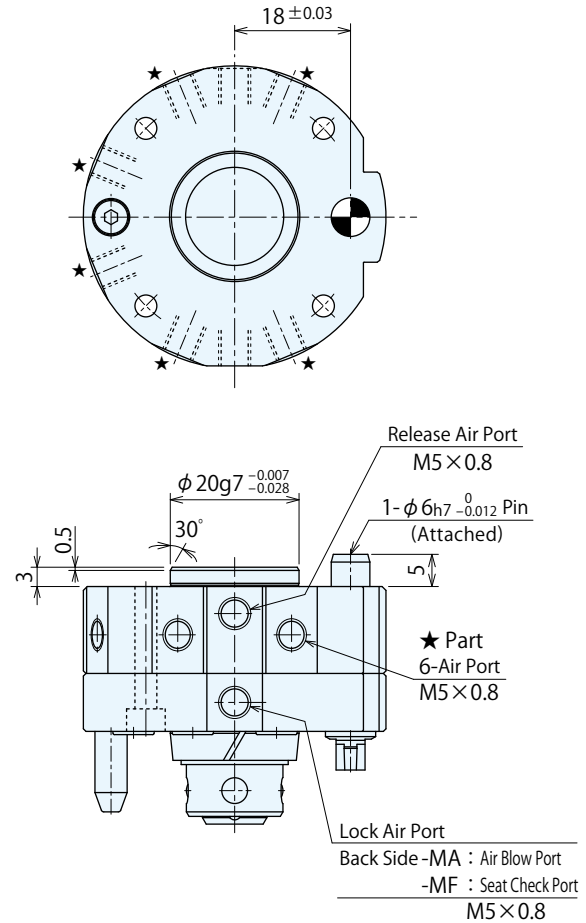
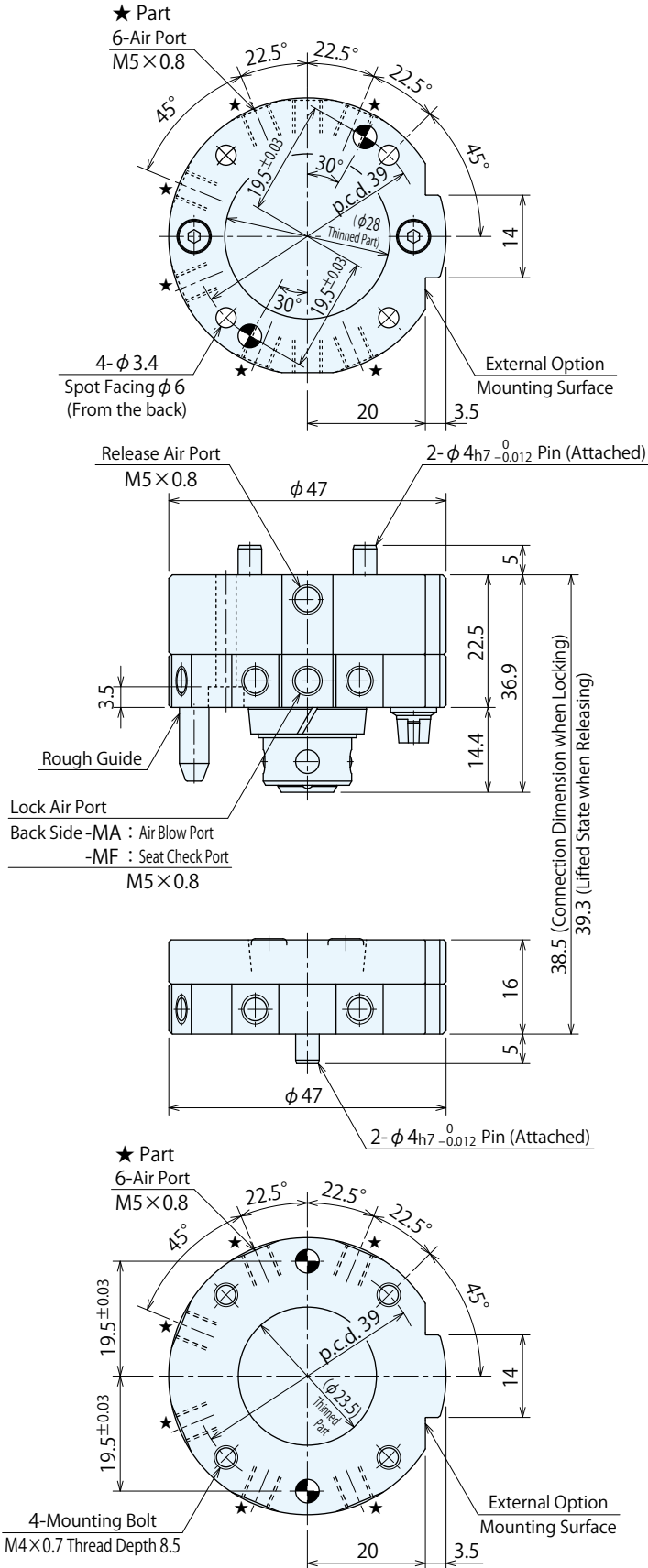

Locating + Clamp

Locating

Hand · Clamp

Support

Valve · Coupler

Cautions · Others

Robotic Hand Changer

SWR Payload 3kg ~ 360kg

SWR0010 Payload 0.5kg ~ 1kg

Manual Robotic Hand Changer

SXR

Pneumatic Location Clamp

SWT

Compact Pneumatic Location Clamp

SWQ

High-Power Pneumatic Pallet Clamp

WVS

External Dimensions (SWR0120)

※ This drawing shows the released state of SWR0120.

Master Cylinder (Standard)
SWR0120-M□

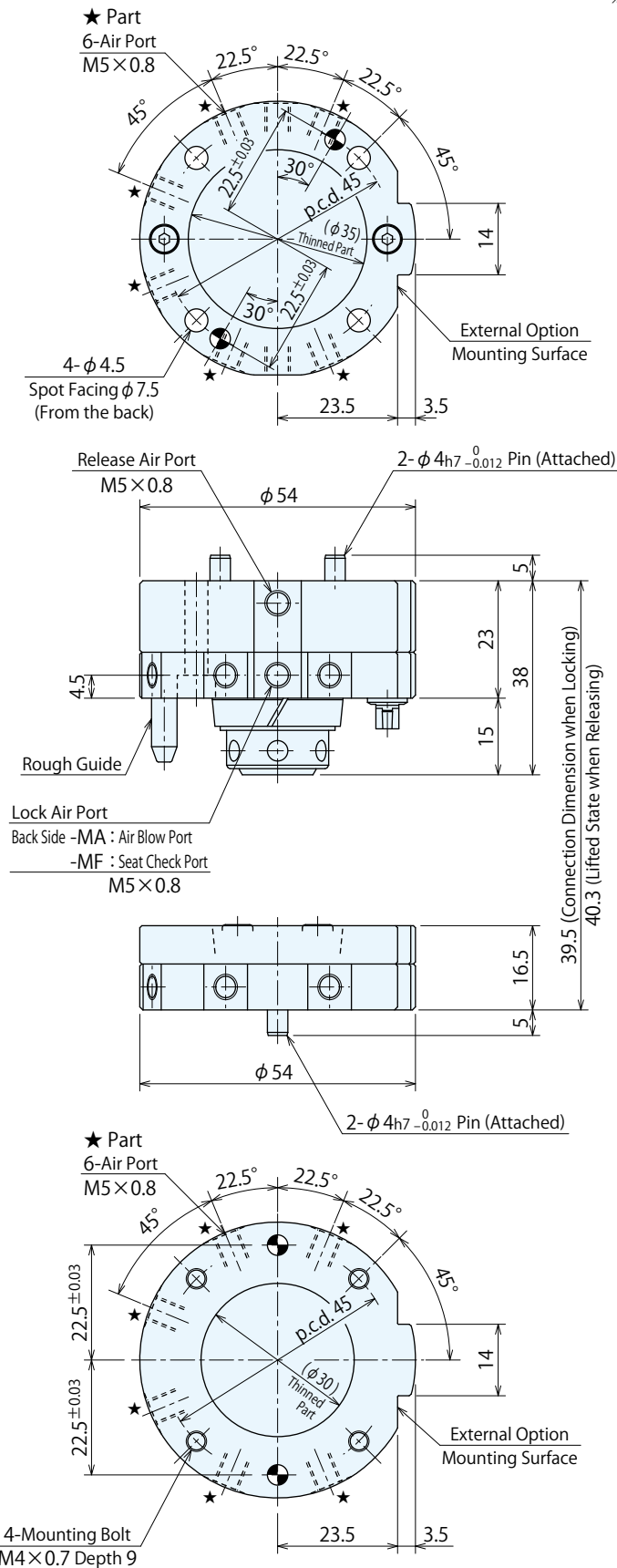

Tool Adapter SWR0120-T

Master Cylinder (with Check Valve)
SWR0120-M□-S

※ The air port positions and **mounting dimensions** are different from those of the standard option. Only the different dimensions are described below.

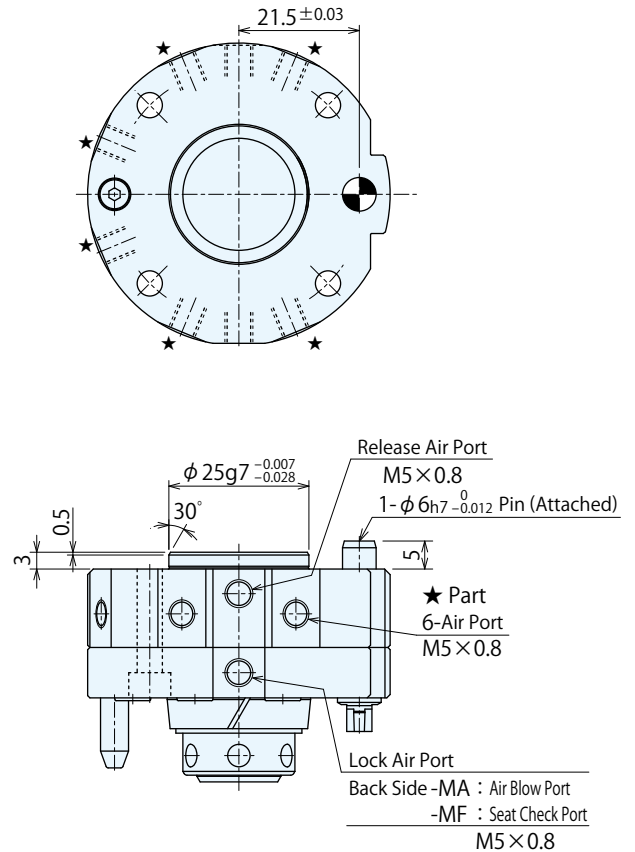

External Dimensions (SWR0250)

※ This drawing shows the released state of SWR0250.

Master Cylinder (Standard)
SWR0250-M□

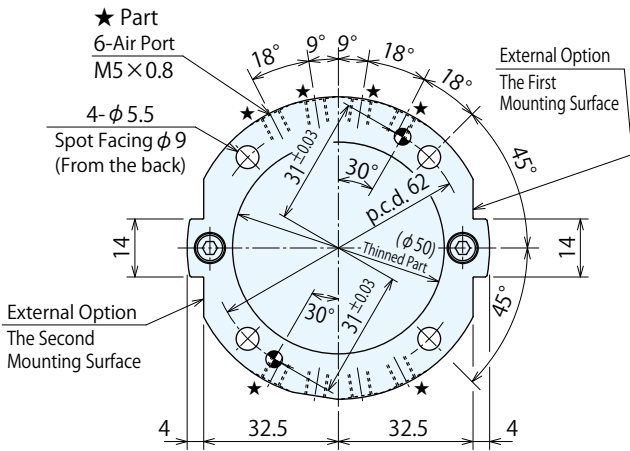

Master Cylinder (with Check Valve)
SWR0250-M□-S

※ The air port positions and **mounting dimensions are different** from those of the standard option.
Only the different dimensions are described below.

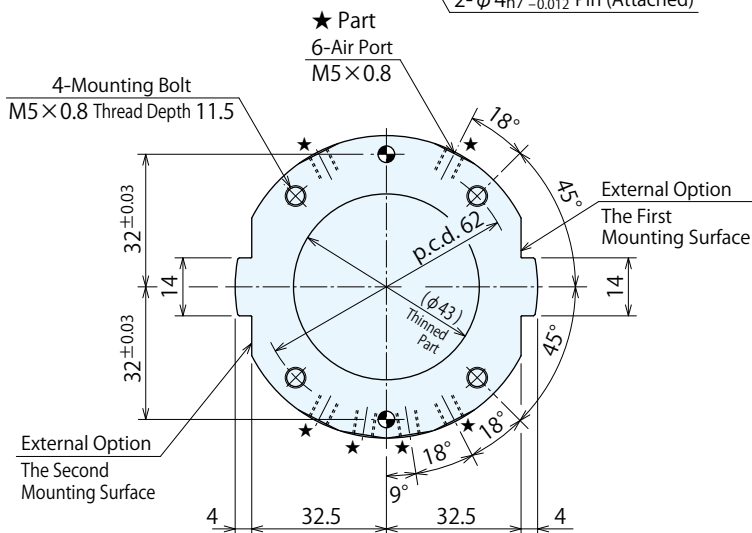
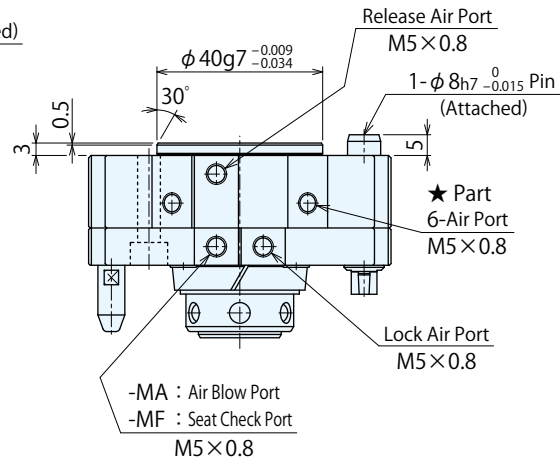
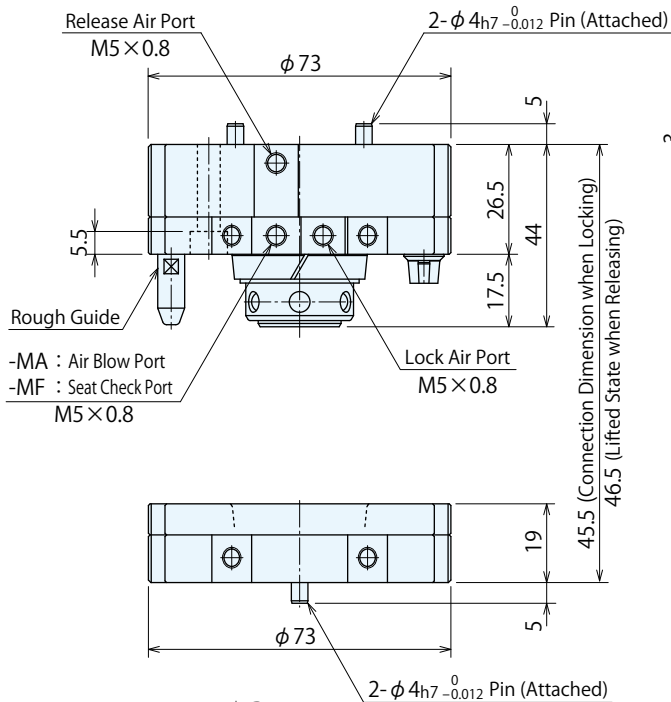
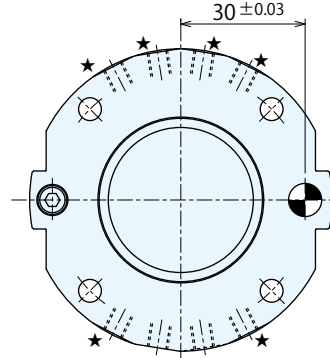

Tool Adapter **SWR0250-T**

Locating + Clamp

Locating

Hand · Clamp

Support

Valve · Coupler

Cautions · Others

Robotic Hand Changer

SWR
Payload
3kg ~ 360kg

SWR010
Payload
0.5kg ~ 1kg

Manual Robotic Hand Changer

SXR

Pneumatic Location Clamp

SWT

Compact Pneumatic Location Clamp

SWQ

High-Power Pneumatic Pallet Clamp

WVS

External Dimensions (SWR0500)

※ This drawing shows the released state of SWR0500.

Master Cylinder (Standard / with Check Valve)
SWR0500-M□ / SWR0500-M□-S

※ The different part between the standard and check valve option.
• The Joint Structure

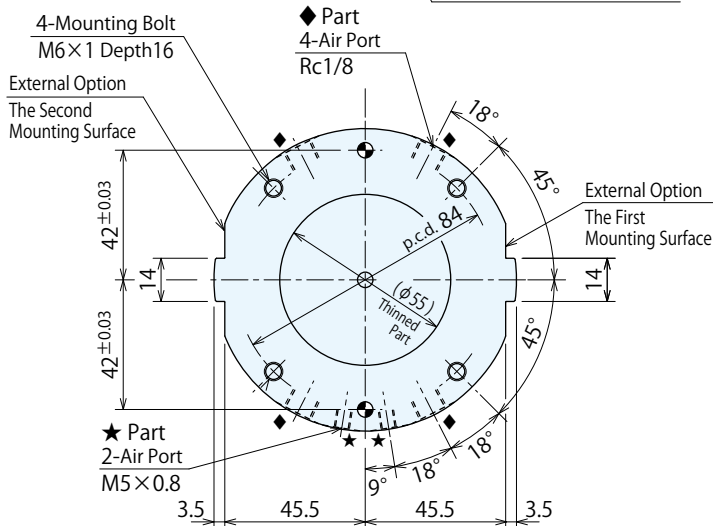
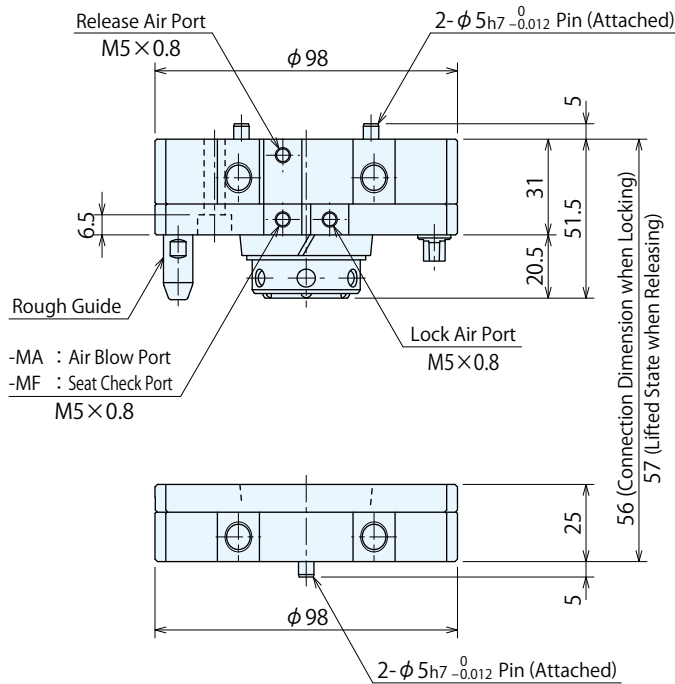
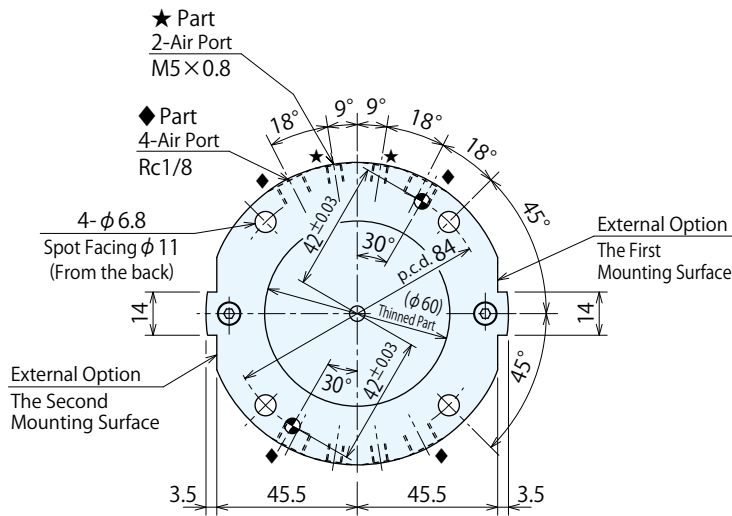

Tool Adapter SWR0500-T

SWR0500-M□-S (With Check Valve)
Joint Structure

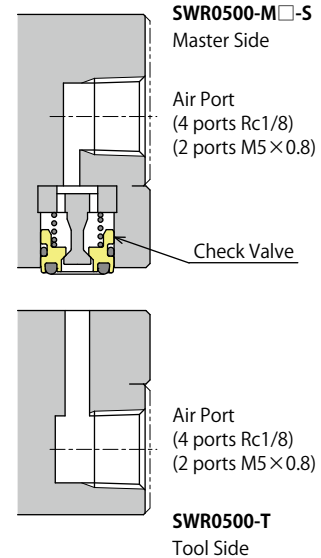

External Dimensions (SWR0750)

※ This drawing shows the released state of SWR0750.

Master Cylinder (Standard / with Check Valve)
SWR0750-M□ / SWR0750-M□-S

※ The different part between the standard and check valve option.
• The Joint Structure

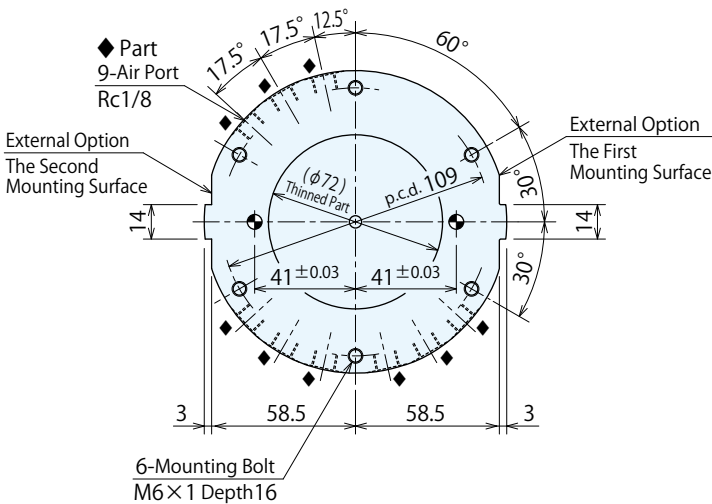
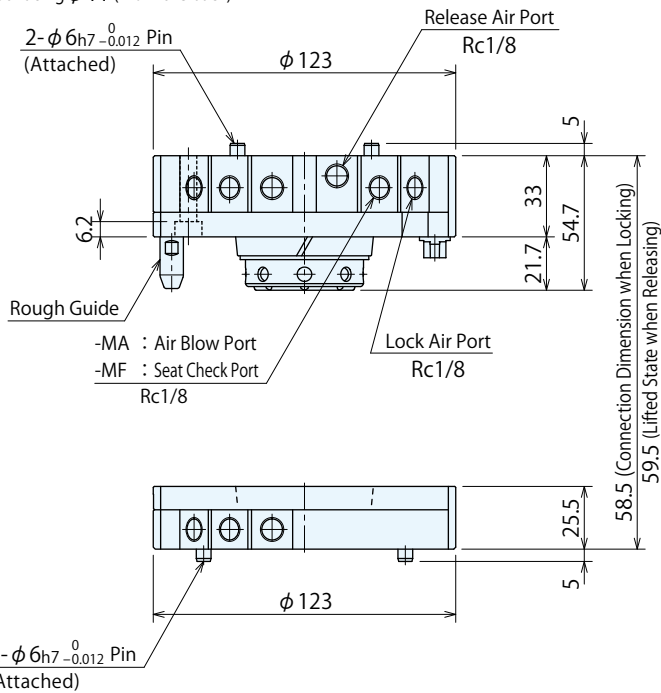
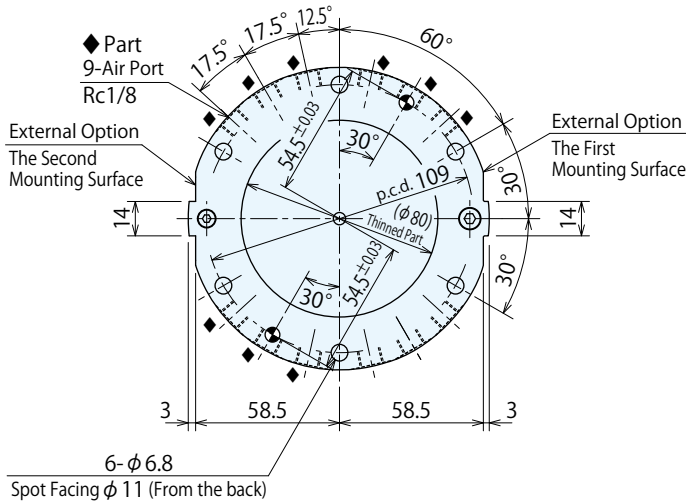

Tool Adapter **SWR0750-T**

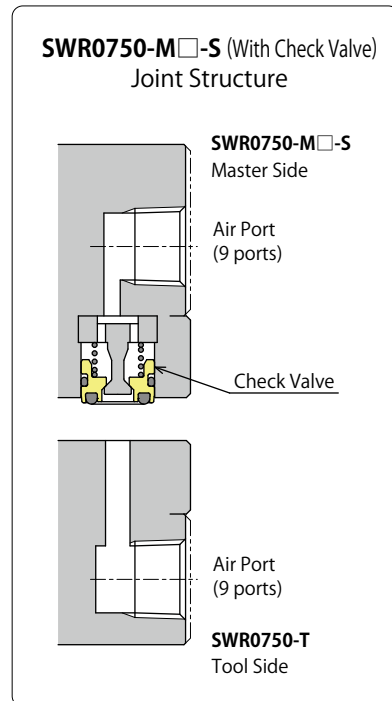

Locating + Clamp
Locating
Hand · Clamp
Support
Valve · Coupler
Cautions · Others

Robotic Hand Changer
SWR Payload 3kg ~ 360kg
SWR0010 Payload 0.5kg ~ 1kg
Manual Robotic Hand Changer
SXR
Pneumatic Location Clamp
SWT
Compact Pneumatic Location Clamp
SWQ
High-Power Pneumatic Pallet Clamp
WVS

External Dimensions (SWR1200)

※ This drawing shows the released state of SWR1200.

Master Cylinder (Standard / with Check Valve)
SWR1200-MAF-□ / SWR1200-MAF-□-S

※ The different part between the standard and check valve option.
 • The Joint Structure

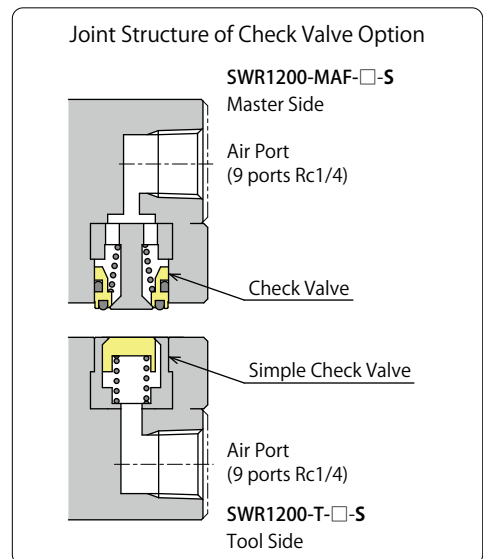
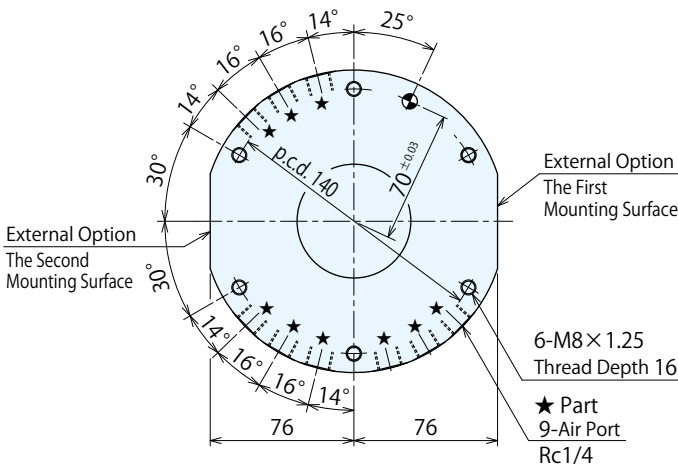
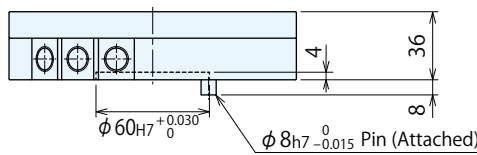
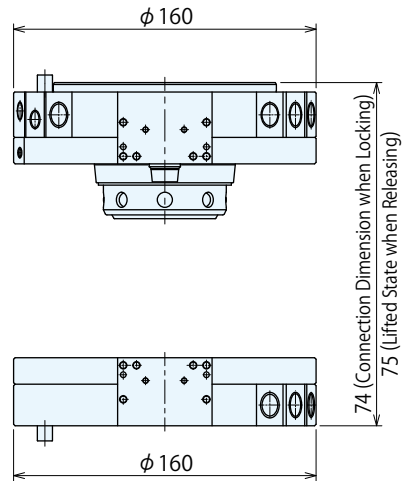
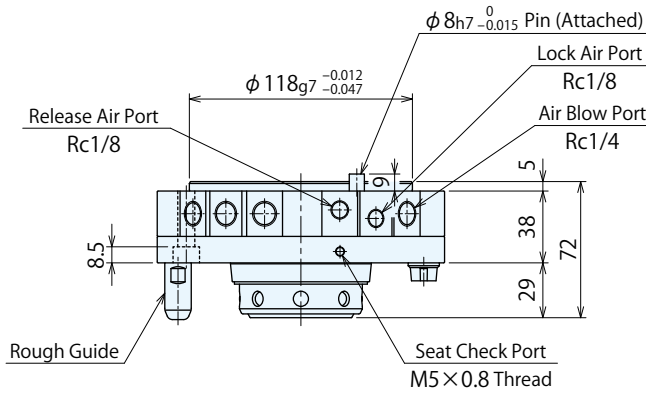
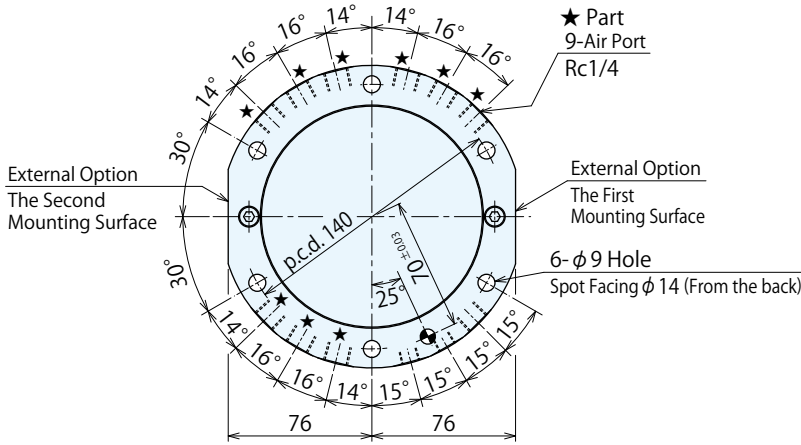

Tool Adapter (Standard / with Check Valve)
SWR1200-T-□ / SWR1200-T-□-S

※ The different part between the standard and check valve option.
 • The Joint Structure
 (Make sure to select the same option as the master cylinder.)

External Dimensions (SWR2300)

※ This drawing shows the released state of SWR2300.

Master Cylinder (Standard / with Check Valve)
SWR2300-MAF-□ / SWR2300-MAF-□-S

※ The different part between the standard and check valve option.
• The Joint Structure

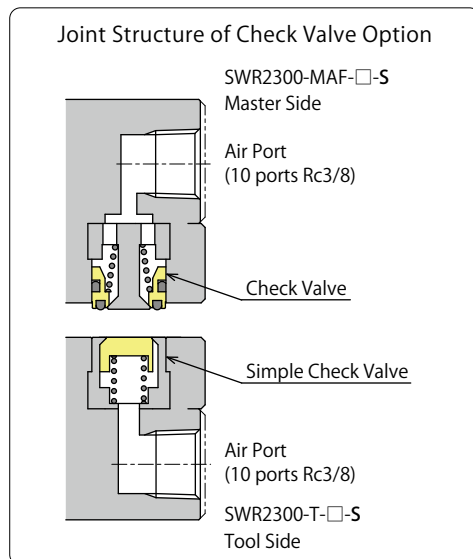
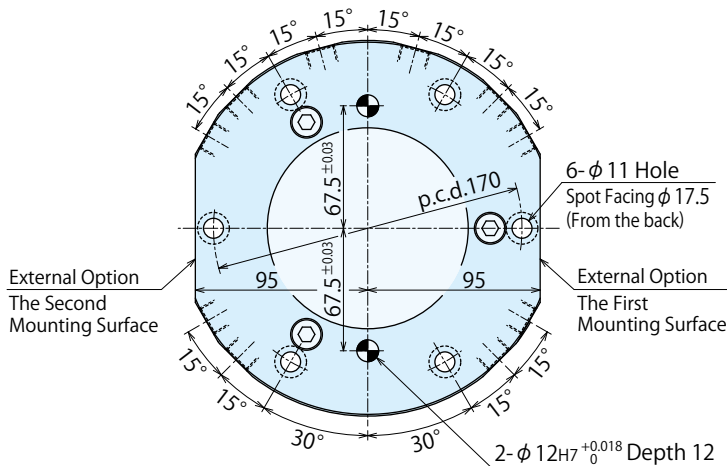
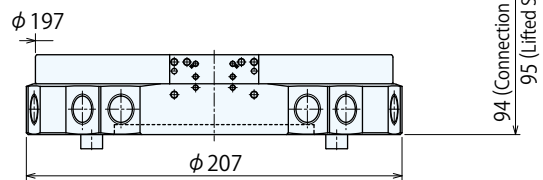
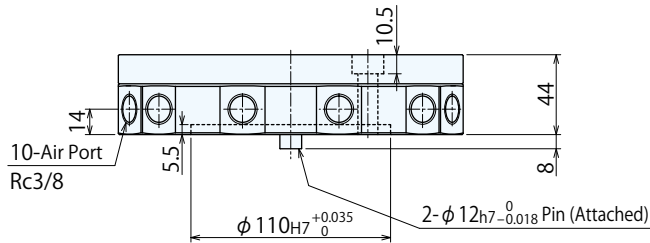
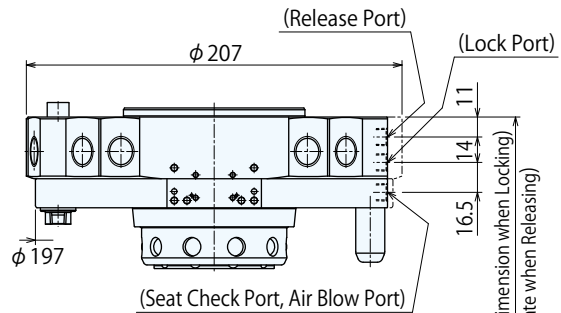
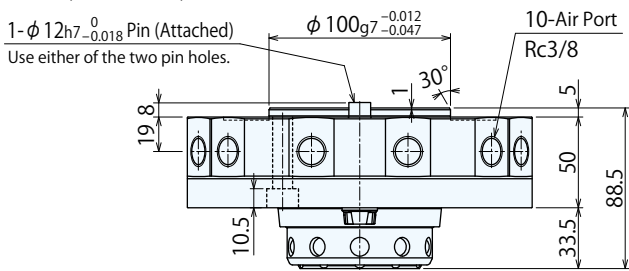
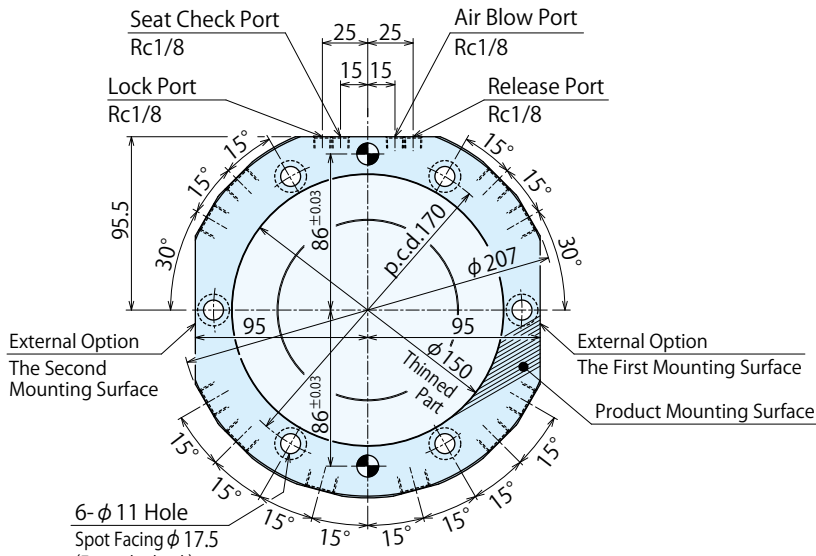

Tool Adapter (Standard / with Check Valve)
SWR2300-T-□ / SWR2300-T-□-S

※ The different part between the standard and check valve option.
• The Joint Structure
(Make sure to select the same option as the master cylinder.)

Locating + Clamp
Locating
Hand + Clamp
Support
Valve + Coupler
Cautions + Others

Robotic Hand Changer

SWR Payload 3kg ~ 360kg
SWR010 Payload 0.5kg ~ 1kg

Manual Robotic Hand Changer
SXR

Pneumatic Location Clamp
SWT

Compact Pneumatic Location Clamp
SWQ

High-Power Pneumatic Pallet Clamp
WVS

Option Mounting Dimensions (SWR0030 ~ SWR0120)

Electrodes and fixtures provided by other than Kosmek, can be mounted with option mounting bolts. This drawing shows the connected state of the master side and tool side.

SWR0030-M / SWR0030-T

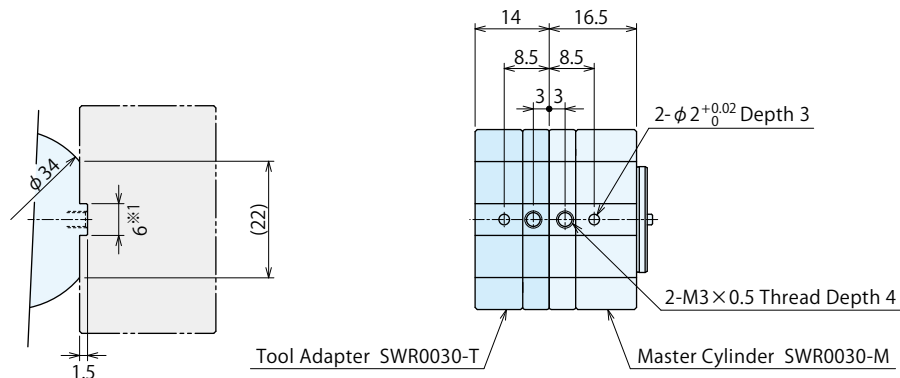

※1. Recommended width of option side is $6^{+0.10}_{+0.05}$.

SWR0070-M□ / SWR0070-T

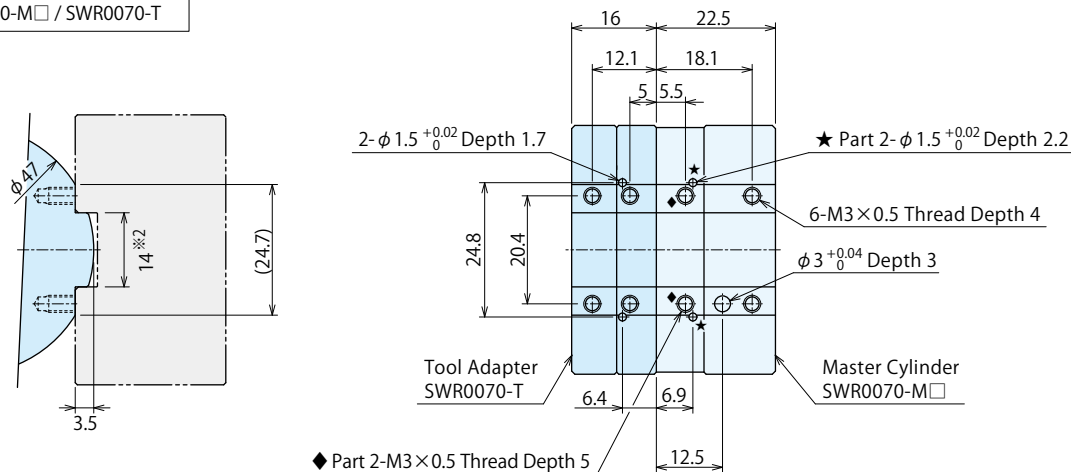

※2. Recommended width of option side is $14^{+0.15}_{+0.05}$.

SWR0120-M□ / SWR0120-T

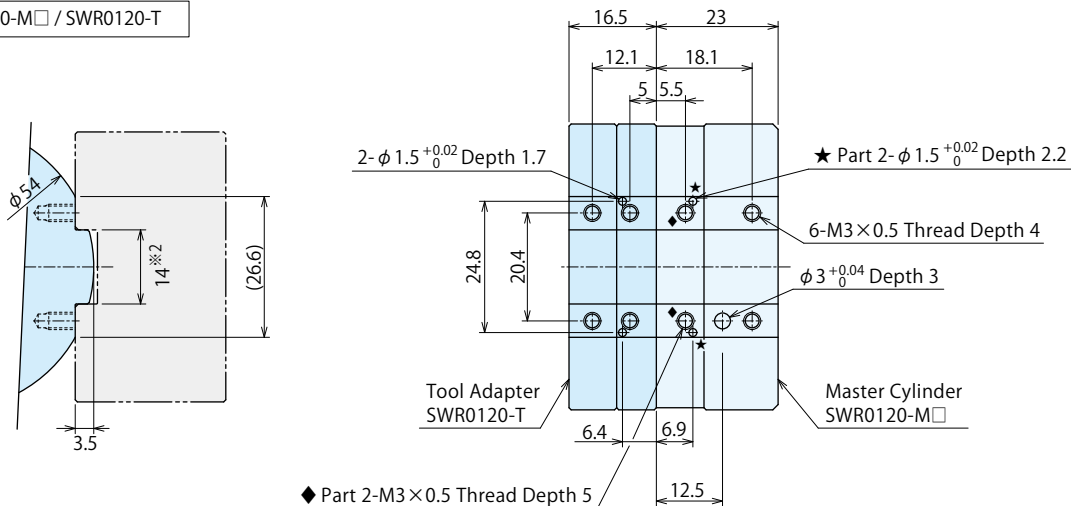

※2. Recommended width of option side is $14^{+0.15}_{+0.05}$.

Option Mounting Dimensions (SWR0250 ~ SWR2300)

Electrodes and fixtures provided by other than Kosmek, can be mounted with option mounting bolts.
This drawing shows the connected state of the master side and tool side.

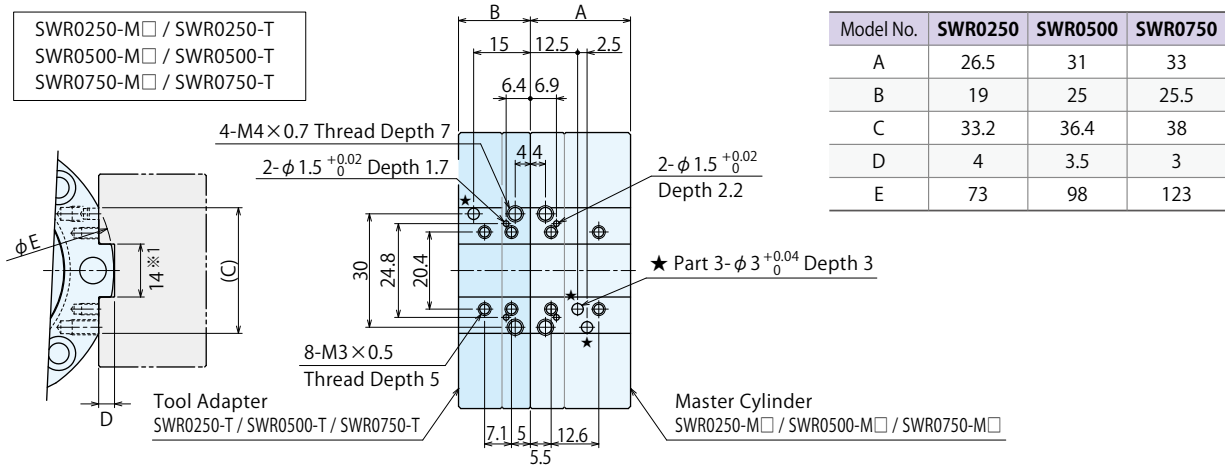

※1. Recommended width of option side is $14 \begin{smallmatrix} +0.15 \\ +0.05 \end{smallmatrix}$.

SWR1200-MAF-□ / SWR1200-T-□

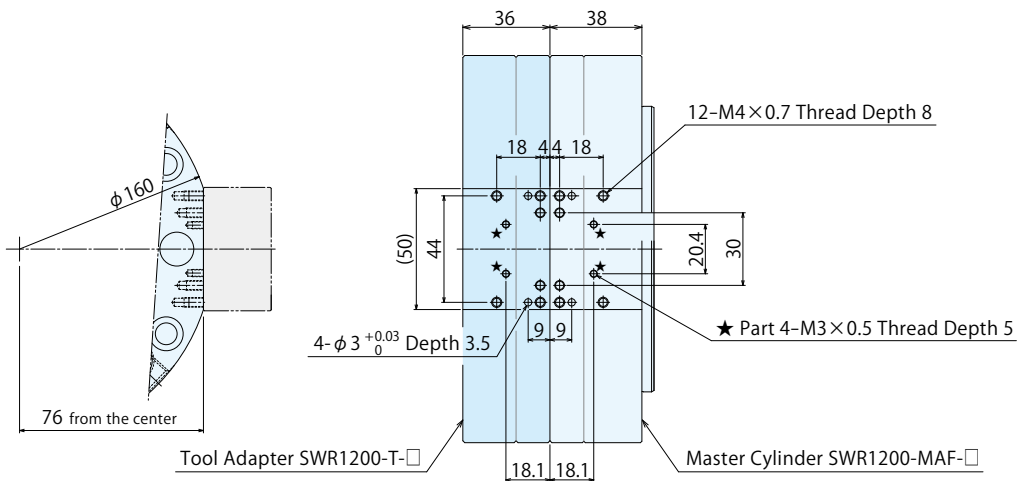

SWR2300-MAF-□ / SWR2300-T-□

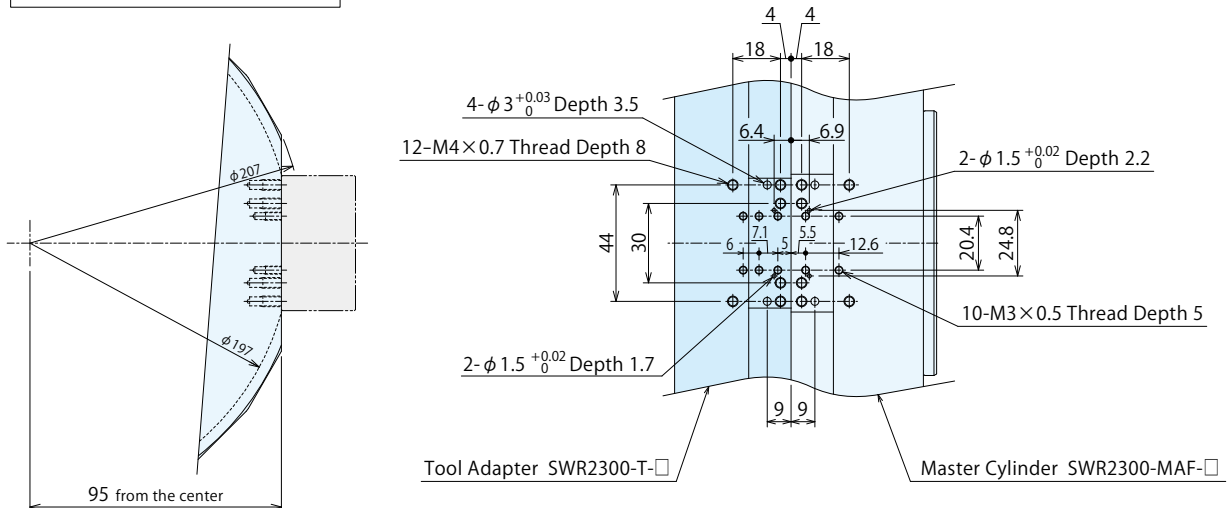

- Locating + Clamp
- Locating
- Hand · Clamp
- Support
- Valve · Coupler
- Cautions · Others

Robotic Hand Changer

SWR Payload 3kg ~ 360kg
SWR010 Payload 0.5kg ~ 1kg

Manual Robotic Hand Changer
SXR

Pneumatic Location Clamp
SWT

Compact Pneumatic Location Clamp
SWQ

High-Power Pneumatic Pallet Clamp
WVS

External Option : Resin Connector

External Option Symbol : J



Specifications

Rated Value (per contact)	DC 24V 2A : Pin 1,3,5,7,9,11,13,15 1A : Pin 2,4,6,8,10,12,14,16
Resin Connector	DF11-16DP-2DS(52) (HIROSE ELECTRIC)
Contact Resistance (Initial Value)	30mΩ or less
Total Current Capacity	10A
Number of Poles (per electrode)	16
Connector Pin Coating	Gold Coating
Weight ※1	Master Cylinder Side Electrode 13g Bracket for SWR0030-M : 10g Bracket for SWR1200-M : 18g
	Tool Adapter Side Electrode 11g Bracket for SWR0030-T : 8g Bracket for SWR1200-T : 16g
Cable with Applicable Connector (Sold Separately)	SWZ0J0-CL□ (Refer to P.39)

※ 1. Weight per electrode. Bracket weight shows the weight of SWRZ0S0-□, SWRZ0B0-120□B.

Connecting Cable

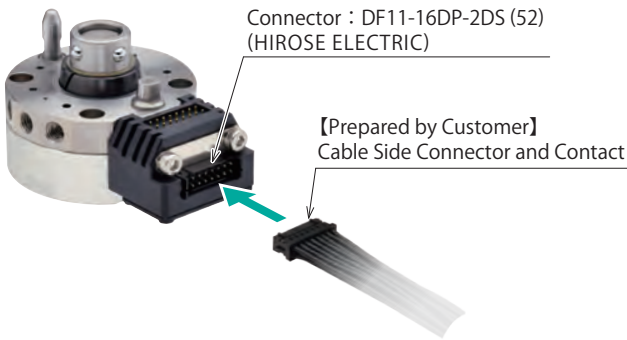

The cable side (connector, contact, cable) is not included.

Please prepare the cable with applicable connector (SWZ0J0-CL□) on P.39, or design them yourself referring to the following list.

Cable Side Connector Model No.	Cable Side Contact Model No.	Recommended Wire Size	Protective Tool		Maker
			Manual Crimping Tool	Contact Removal Tool	
DF11-16DS-2C	DF11-22SCA	AWG22	DF11-TA22HC	DF-C-PO(B)	HIROSE ELECTRIC
	DF11-2428SCA	AWG24 ~ 28	DF11-TA2428HC		

Notes : 1. Refer to HIROSE ELECTRIC catalogs for the detailed specifications and the rated current based on wire size.
2. The model number of connector required for the master cylinder and the tool adapter is the same.

External Dimensions (SWR0070/SWR0120/SWR0250/SWR0500/SWR0750/SWR2300)

Master Cylinder Side			
SWR0070-M□-J	SWR0120-M□-J	SWR0250-M□-J	SWR0500-M□-J
SWR0750-M□-J	SWR2300-MAF-J		

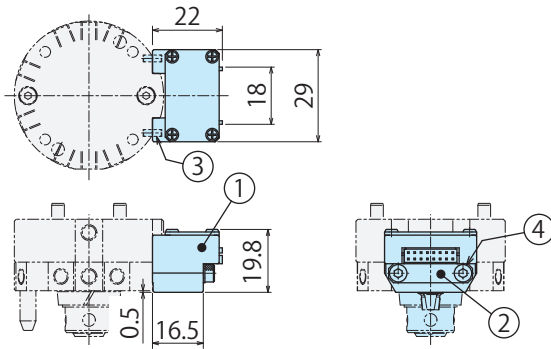

Model No.	No.	Name	Quantity
			J: 16 poles
SWRZ0J0-M	①	Electrode (Master Side)	1
	②	Spacer	1
	③	Parallel Pin φ1.5×4 B Type (SUS)	2
	④	Hexagon Socket Bolt M3×0.5×20 (SUS)	2

Tool Adapter Side			
SWR0070-T-J	SWR0120-T-J	SWR0250-T-J	SWR0500-T-J
SWR0750-T-J	SWR2300-T-J		

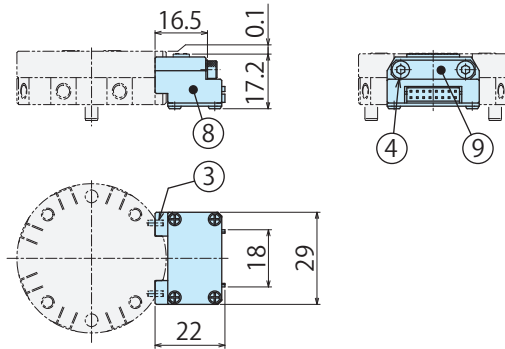

Model No.	No.	Name	Quantity
			J: 16 poles
SWRZ0J0-T	⑧	Electrode (Tool Side)	1
	⑨	Spacer	1
	③	Parallel Pin φ1.5×4 B Type (SUS)	2
	④	Hexagon Socket Bolt M3×0.5×20 (SUS)	2

Notes :

1. Inform us with the model number shown above if you require an electrode only. (SWRZ0J0-□ : one set is one electrode.)
2. Prepare additional mounting bolts by customer when extending another electrode. See P.35 ~ P.36 for mounting thread depth.

External Dimensions (SWR0030)

Master Cylinder Side

SWR0030-M-J ※ SWRZ050-M is mounted for SWR0030-M-J.

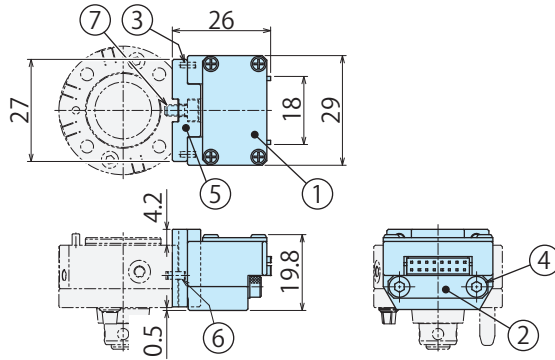

Model No.	No.	Name	Quantity J: 16 poles
SWRZ0J0-M	①	Electrode (Master Side)	1
	②	Spacer	1
	③	Parallel Pin $\phi 1.5 \times 4$ B Type (SUS)	2
	④	Hexagon Socket Bolt M3×0.5×20 (SUS)	2
SWRZ050-M	⑤	Bracket (Master Side)	1
	⑥	Parallel Pin $\phi 2 \times 6$ B Type (SUS)	1
	⑦	Hexagon Socket Bolt M3×0.5×6 (SUS)	1

Note :

1. Inform us with the model number shown above if you require an electrode only. (SWRZ0J0-□ : one set is one electrode.)

External Dimensions (SWR1200)

Master Cylinder Side

SWR1200-MAF-J ※ Please install SWRZ0B0-120MB only for SWR1200-MAF-J.

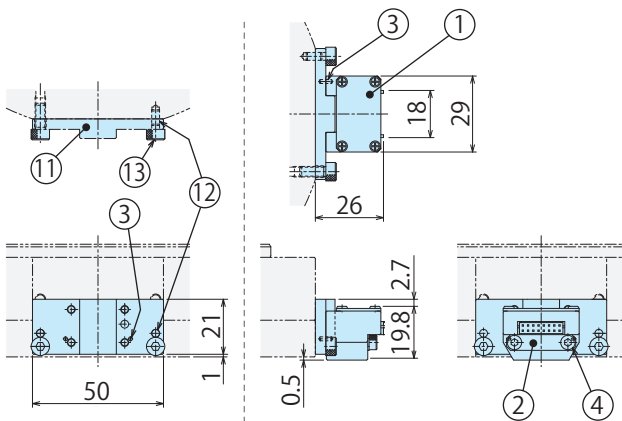

Model No.	No.	Name	Quantity J: 16 poles
SWRZ0J0-M	①	Electrode (Master Side)	1
	②	Spacer	1
	③	Parallel Pin $\phi 1.5 \times 4$ B Type (SUS)	2
	④	Hexagon Socket Bolt M3×0.5×20 (SUS)	2
SWRZ0B0-120MB	⑪	Bracket (Master Side)	1
	⑫	Parallel Pin $\phi 3 \times 6$ B Type (SUS)	1
	⑬	Hexagon Socket Bolt M4×0.7×10 (SUS)	1

Notes :

1. Inform us with the model number shown above if you require an electrode only. (SWRZ0J0-□ : one set is one electrode.)
2. Prepare additional mounting bolts by customer when extending another electrode. See P.36 for mounting thread depth.

Tool Adapter Side

SWR0030-T-J ※ SWRZ050-T is mounted for SWR0030-T-J.

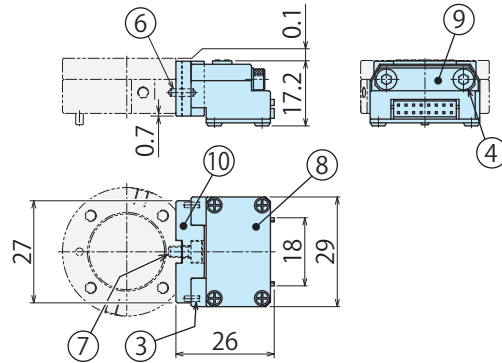

Model No.	No.	Name	Quantity J: 16 poles
SWRZ0J0-T	⑧	Electrode (Tool Side)	1
	⑨	Spacer	1
	③	Parallel Pin $\phi 1.5 \times 4$ B Type (SUS)	2
	④	Hexagon Socket Bolt M3×0.5×20 (SUS)	2
SWRZ050-T	⑩	Bracket (Tool Side)	1
	⑥	Parallel Pin $\phi 2 \times 6$ B Type (SUS)	1
	⑦	Hexagon Socket Bolt M3×0.5×6 (SUS)	1

Tool Adapter Side

SWR1200-T-J ※ Please install SWRZ0B0-120TB only for SWR1200-T-J.

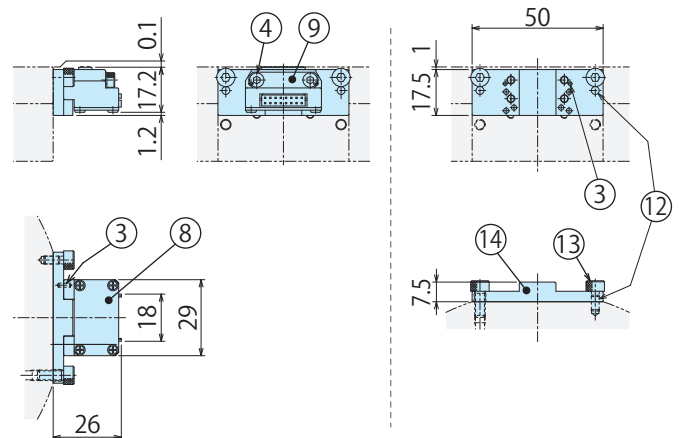

Model No.	No.	Name	Quantity J: 16 poles
SWRZ0J0-T	⑧	Electrode (Tool Side)	1
	⑨	Spacer	1
	③	Parallel Pin $\phi 1.5 \times 4$ B Type (SUS)	2
	④	Hexagon Socket Bolt M3×0.5×20 (SUS)	2
SWRZ0B0-120TB	⑭	Bracket (Tool Side)	1
	⑫	Parallel Pin $\phi 3 \times 6$ B Type (SUS)	2
	⑬	Hexagon Socket Bolt M4×0.7×10 (SUS)	2

Locating
+
Clamp

Locating

Hand • Clamp

Support

Valve • Coupler

Cautions • Others

Robotic
Hand Changer

SWR
Payload
3kg ~ 360kg

SWR0010
Payload
0.5kg ~ 1kg

Manual Robotic
Hand Changer

SXR

Pneumatic
Location Clamp

SWT

Compact Pneumatic
Location Clamp

SWQ

High-Power Pneumatic
Pallet Clamp

VVS

External Option : Cable with Connector for Resin Connector

This cable is an optional cable applicable to the Resin Connector Electrode (SWR External Option Symbol : J).

Model No. Indication

SWZ0J0-C

L1
L2

Cable Length
L1 : 1m
L2 : 2m

Design No.
(Revision Number)

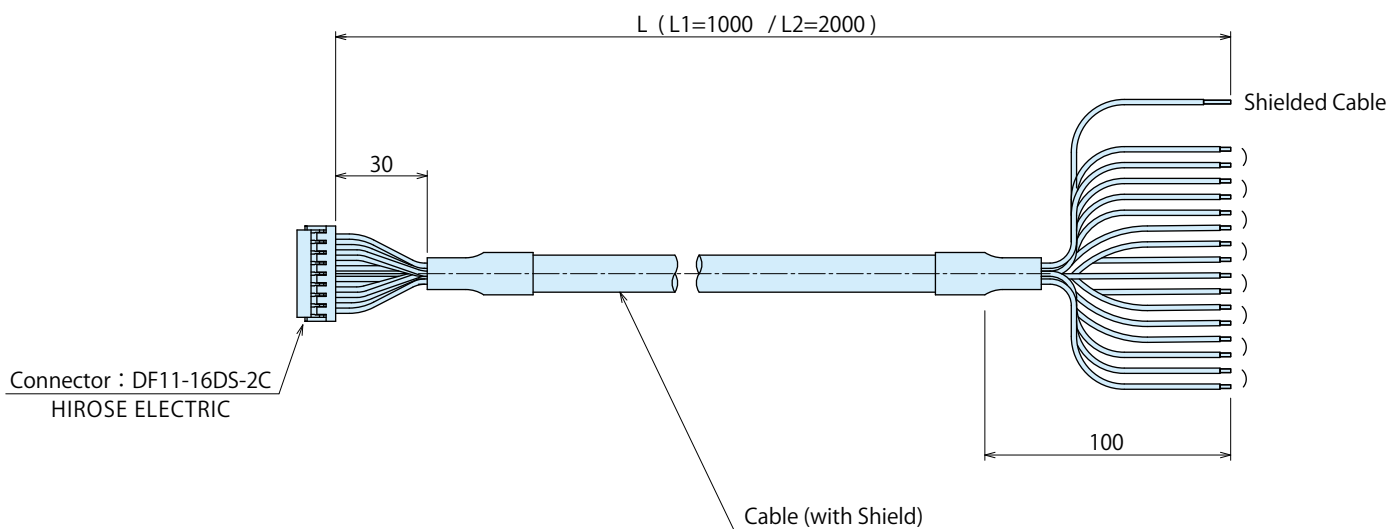

【 Important 】 Announcement of Cable Specifacaton Change

We are using the new robot cable due to its performance and flexibility improvement.
Please make sure to check the specifications of the new cable shown on the next page.



Current Cable

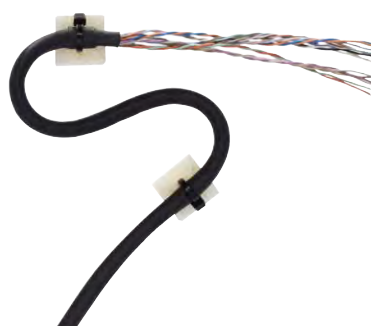

New Cable

Scheduled to change in January, 2020. (Replacement period is subject to change due to the stock condition.)

Pin Numbers and Wire Colors

[Important] Wire colors of the new cable and the current cable are different.

New Cable

HIFLON SD-SB/20276 Black AWG24X8P (with Shield)
 NISSEI ELECTRIC Weight : 76g /m (Weight per meter)
 Conductor Cross-Sectional Area : 0.2mm² (AWG24)
 Number of Cores : 16



Rated Current	2A								1A							
Pin Number	1	3	5	7	9	11	13	15	2	4	6	8	10	12	14	16
Wire Color	Black	White	Red	Green	Yellow	Brown	Blue	Orange	Gray	Violet	Light Blue	Pink	White/Black	White/Red	White/Blue	Yellow/Black
	Twisted Pair		Twisted Pair		Twisted Pair		Twisted Pair		Twisted Pair		Twisted Pair		Twisted Pair		Twisted Pair	

Current Cable

ORP—0.2SQX8P(SB) (2464) (with Shield)
 Oki Electric Cable Weight : 101g /m (Weight per meter)
 Conductor Cross-Sectional Area : 0.2mm² (AWG25)
 Number of Cores : 16



Rated Current	2A								1A							
Pin Number	1	3	5	7	9	11	13	15	2	4	6	8	10	12	14	16
Wire Color	Blue	White	Yellow	Brown	Green	Black	Red	Gray	Violet	Orange	Blue	Brown	Yellow	Black	Green	Gray
	Twisted Pair		Twisted Pair		Twisted Pair		Twisted Pair		Twisted Pair		Twisted Pair		Twisted Pair		Twisted Pair	

Note : Wire/Cable Procedure and Wiring

- Make sure to fix the wire and cable so that they are not pulled while a robot is moving or turning around.
 External force should not be applied on the connector part since it leads to breaking of wire, detaching of connector and contact failure.

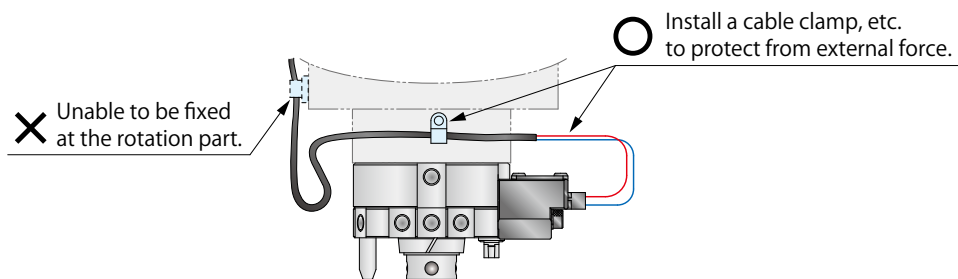

- Locating + Clamp
- Locating
- Hand · Clamp
- Support
- Valve · Coupler
- Cautions · Others
- Robotic Hand Changer
 - SWR Payload 3kg ~ 360kg
 - SWR0010 Payload 0.5kg ~ 1kg
- Manual Robotic Hand Changer
 - SXR
- Pneumatic Location Clamp
 - SWT
- Compact Pneumatic Location Clamp
 - SWQ
- High-Power Pneumatic Pallet Clamp
 - VVS

External Option : Solder Terminal

External Option Symbol : B

Master Cylinder
model SWR □ 0-M □ -B



Tool Adapter
model SWR □ 0-T □ -B



Specifications

Rated Value (per contact)	DC 24V 3A
Contact Resistance (Initial Value)	100mΩ or less
Total Current Capacity	10A
Number of Poles (per electrode)	15
Weight ※1	Master Cylinder Side Electrode 15g Bracket for SWR0030-M : 10g Bracket for SWR1200-M : 18g
	Tool Adapter Side Electrode 11g Bracket for SWR0030-T : 8g Bracket for SWR1200-T : 16g

※1. Weight per electrode. Bracket weight shows the weight of SWRZ050-□, SWRZ0B0-120□B.

External Dimensions : Electrode

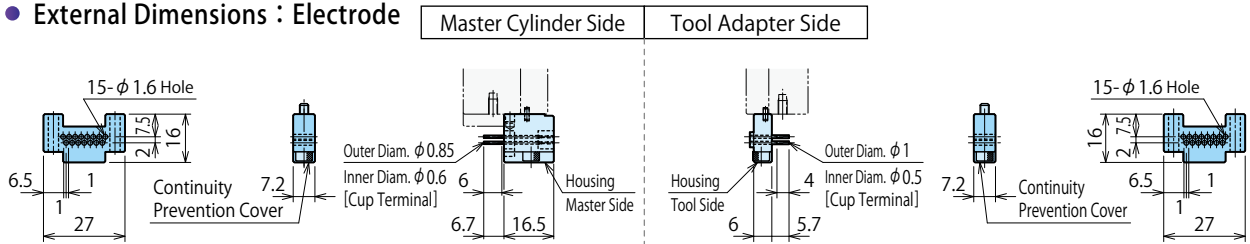

External Dimensions (SWR0070/SWR0120/SWR0250/SWR0500/SWR0750/SWR2300)

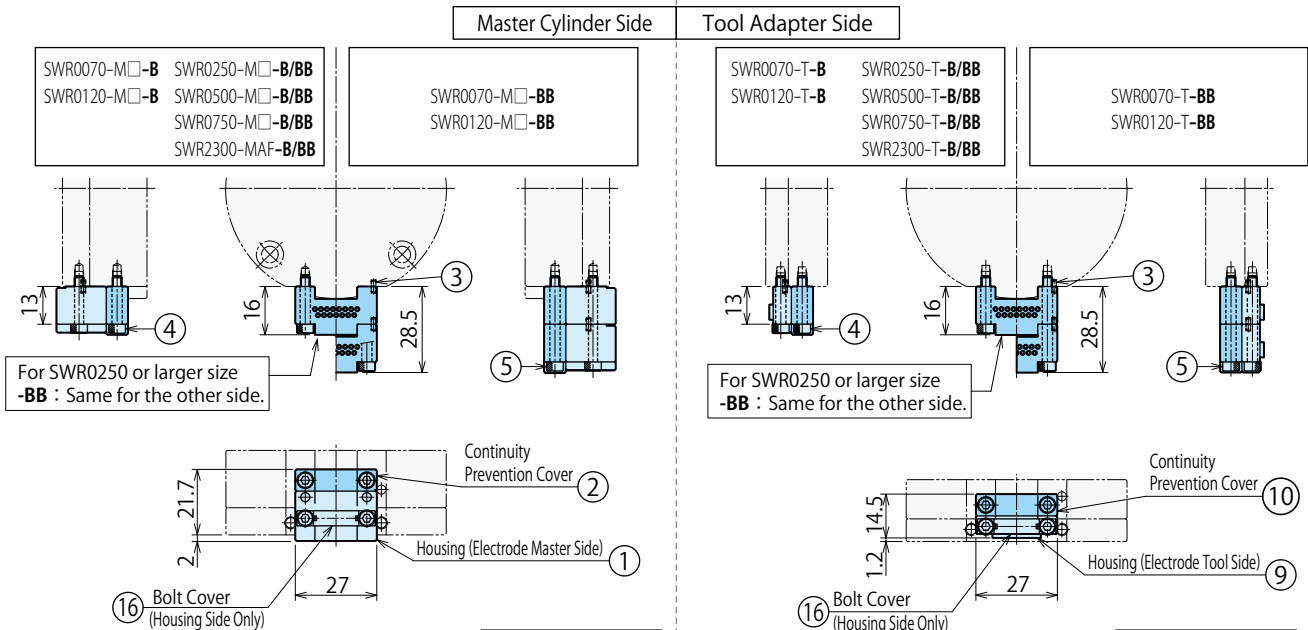

Model No.	No.	Name	Quantity		
			B : 15 poles	BB : 30 poles SWR0120 or smaller	SWR0250 or larger
SWRZ0B0-M	①	Electrode (Master Side)	1	2	
	②	Continuity Prevention Cover	1	2	
	③	Parallel Pin φ1.5×4 B Type (SUS)	2	4	
4SW101785-00※2	⑬	Bolt Cover	1	1	2
- ※2	④	Hexagon Socket Bolt M3×0.5×16 (SUS)	4	-	8
- ※2	⑤	Hexagon Socket Bolt M3×0.5×30 (SUS)	-	4	-

Model No.	No.	Name	Quantity		
			B : 15 poles	BB : 30 poles SWR0120 or smaller	SWR0250 or larger
SWRZ0B0-T	⑨	Electrode (Tool Side)	1	2	
	⑩	Continuity Prevention Cover	1	2	
	③	Parallel Pin φ1.5×4 B Type (SUS)	2	4	
4SW101785-00※2	⑬	Bolt Cover	1	1	2
- ※2	④	Hexagon Socket Bolt M3×0.5×16 (SUS)	4	-	8
- ※2	⑤	Hexagon Socket Bolt M3×0.5×30 (SUS)	-	4	-

Note : 1. Inform us with the model number shown above if you require an electrode only. (SWRZ0B0-□ : one set is one electrode.)
For SWRZ0B0-M/SWRZ0B0-T, the bolt and bolt cover marked with ※2 are not included.

External Dimensions (SWR0030)

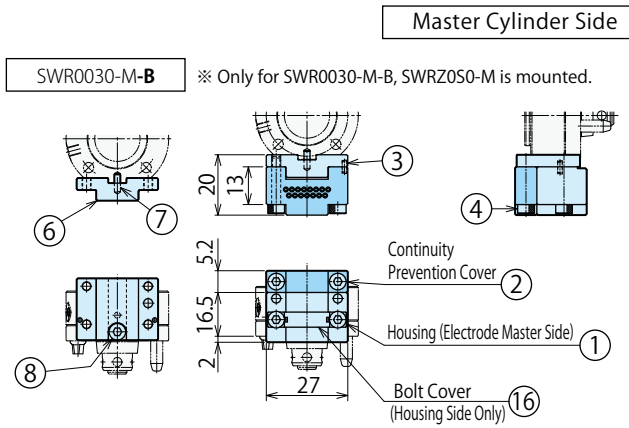

Model No.	No.	Name	Quantity
SWRZ0B0-M	①	Electrode (Master Side)	1
	②	Continuity Prevention Cover	1
	③	Parallel Pin $\phi 1.5 \times 4$ B Type (SUS)	2
4SW101785-00 ※2	⑩	Bolt Cover	1
	④	Hexagon Socket Bolt M3 \times 0.5 \times 16 (SUS)	4
SWRZ050-M	⑥	Bracket (Master Side)	1
	⑦	Parallel Pin $\phi 2 \times 6$ B Type (SUS)	1
	⑧	Hexagon Socket Bolt M3 \times 0.5 \times 6 (SUS)	1

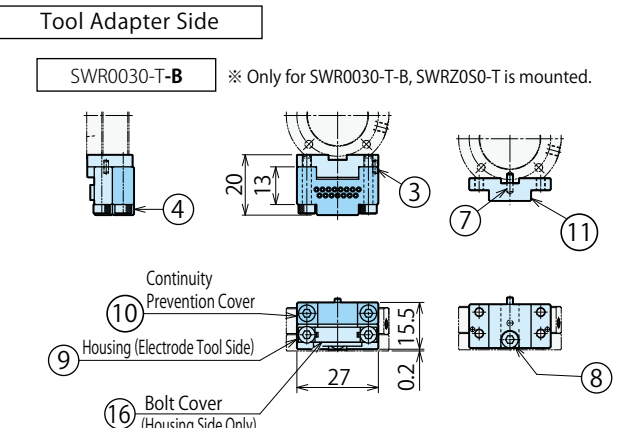

Model No.	No.	Name	Quantity
SWRZ0B0-T	⑨	Electrode (Tool Side)	1
	⑩	Continuity Prevention Cover	1
	③	Parallel Pin $\phi 1.5 \times 4$ B Type (SUS)	2
4SW101785-00 ※2	⑩	Bolt Cover	1
	④	Hexagon Socket Bolt M3 \times 0.5 \times 16 (SUS)	4
SWRZ050-T	⑪	Bracket (Tool Side)	1
	⑦	Parallel Pin $\phi 2 \times 6$ B Type (SUS)	1
	⑧	Hexagon Socket Bolt M3 \times 0.5 \times 6 (SUS)	1

Notes : 1. Inform us with the model number shown above if you require an electrode only. (SWRZ0B0-□ : one set is one electrode.)
 For SWRZ0B0-M/SWRZ050-M/SWRZ0B0-T/SWRZ050-T, the bolt and bolt cover marked with ※2 are not included.
 2. For SWRZ0B0-M/SWRZ0B0-T, the bolt and bolt cover marked with ※2 are not included.

Locating + Clamp
 Locating
 Hand + Clamp
 Support
 Valve + Coupler
 Cautions + Others

Robotic Hand Changer
 SWR Payload 3kg ~ 360kg
 SWR0010 Payload 0.5kg ~ 1kg
 Manual Robotic Hand Changer
 SXR
 Pneumatic Location Clamp
 SWT
 Compact Pneumatic Location Clamp
 SWQ
 High-Power Pneumatic Pallet Clamp
 WVS

External Dimensions (SWR1200)

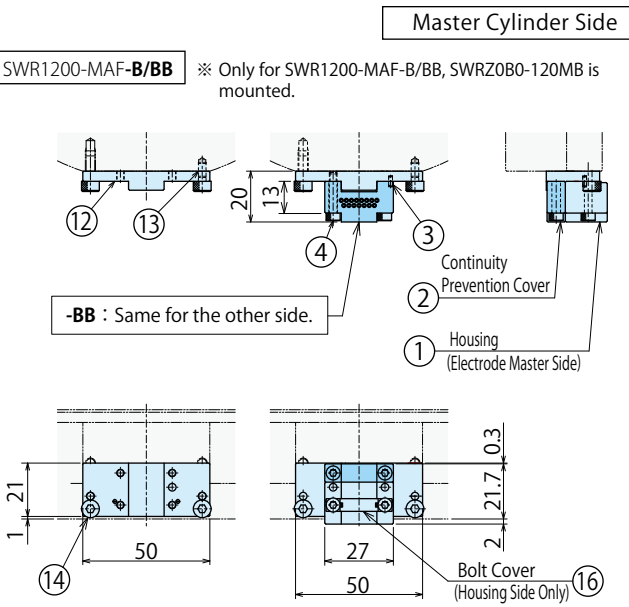

Model No.	No.	Name	Quantity
SWRZ0B0-M	①	Electrode (Master Side)	1
	②	Continuity Prevention Cover	1
	③	Parallel Pin $\phi 1.5 \times 4$ B Type (SUS)	2
4SW101785-00 ※2	⑯	Bolt Cover	1
	④	Hexagon Socket Bolt M3 \times 0.5 \times 16 (SUS)	4
SWRZ0B0-120MB	⑫	Bracket (Master Side)	1
	⑬	Parallel Pin $\phi 3 \times 6$ B Type (SUS)	2
	⑭	Hexagon Socket Bolt M4 \times 0.7 \times 10 (SUS)	2

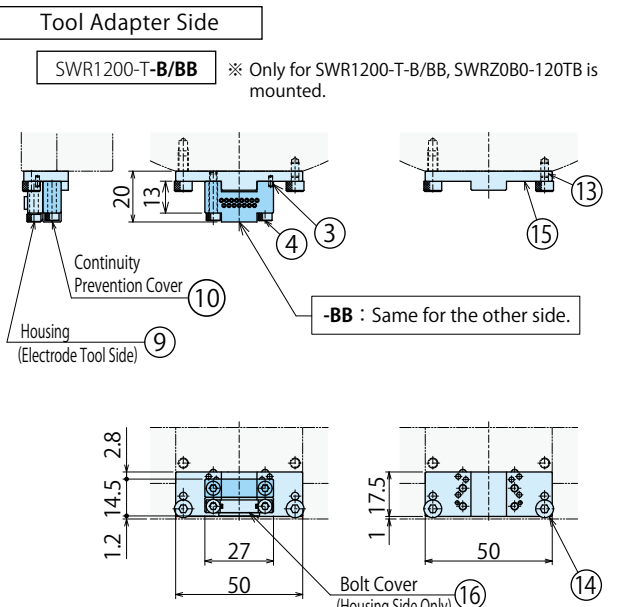

Model No.	No.	Name	Quantity
SWRZ0B0-T	⑨	Electrode (Tool Side)	1
	⑩	Continuity Prevention Cover	1
	③	Parallel Pin $\phi 1.5 \times 4$ B Type (SUS)	2
4SW101785-00 ※2	⑰	Bolt Cover	1
	④	Hexagon Socket Bolt M3 \times 0.5 \times 16 (SUS)	4
SWRZ0B0-120TB	⑮	Bracket (Tool Side)	1
	⑬	Parallel Pin $\phi 3 \times 6$ B Type (SUS)	2
	⑭	Hexagon Socket Bolt M4 \times 0.7 \times 10 (SUS)	2

Note : 1. Inform us with the model number shown above if you require an electrode only. (SWRZ0B0-□ : one set is one electrode.)
 For SWRZ0B0-M / SWRZ0B0-120MB / SWRZ0B0-T / SWRZ0B0-120TB, the bolt and bolt cover marked with ※2 are not included.

External Option : Solder Terminal with Cable

External Option Symbol : C01/C02

Master Cylinder
model SWR □ 0-M □ -

C01
C02



Tool Adapter
model SWR □ 0-T □ -

C01
C02



Specifications

Rated Value (per contact)	DC 24V 3A	
Contact Resistance (Initial Value)	100mΩ or less	
Total Current Capacity	10A	
Number of Poles (per electrode)	15	
Lead Wire Size	Refer to P.45 and P.46	
Lead Wire Length	-C01	1m
	-C02	2m
Weight ※1	Master Cylinder Side	Electrode -C01 : 120g / -C02 : 230g Bracket for SWR0030-M : 10g Bracket for SWR1200-M : 18g
	Tool Adapter Side	Electrode -C01 : 110g / -C02 : 220g Bracket for SWR0030-T : 8g Bracket for SWR1200-T : 16g

※1. Weight per electrode. Bracket weight shows the weight of SWRZ050-□, SWRZ080-120□B.

Master Cylinder Side | Tool Adapter Side

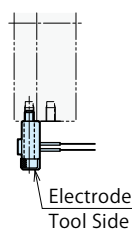
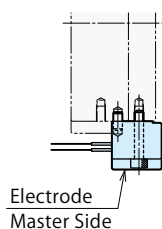

Please refer to P.45 and P.46 for the pin numbers, the wire colors and the cable specifications.

External Dimensions (SWR0070/SWR0120/SWR0250/SWR0500/SWR0750/SWR2300)

Master Cylinder Side

Tool Adapter Side

SWR0070-M□-C□ SWR0250-M□-C□/C□C□
SWR0120-M□-C□ SWR0500-M□-C□/C□C□
SWR0750-M□-C□/C□C□
SWR2300-MAF-C□/C□C□

SWR0070-M□-C□C□
SWR0120-M□-C□C□

SWR0070-T-C□ SWR0250-T-C□/C□C□
SWR0120-T-C□ SWR0500-T-C□/C□C□
SWR0750-T-C□/C□C□
SWR2300-T-C□/C□C□

SWR0070-T-C□C□
SWR0120-T-C□C□

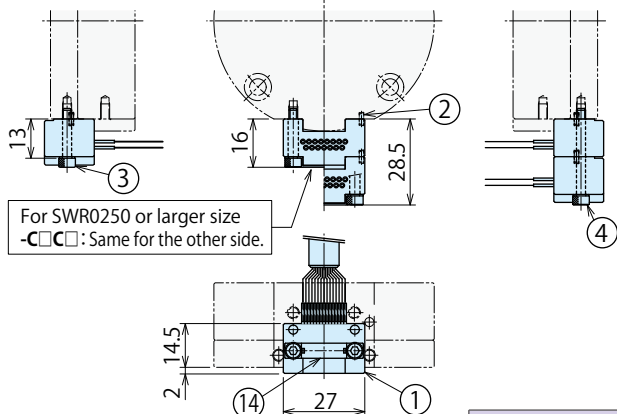

For SWR0250 or larger size
-C□C□ : Same for the other side.

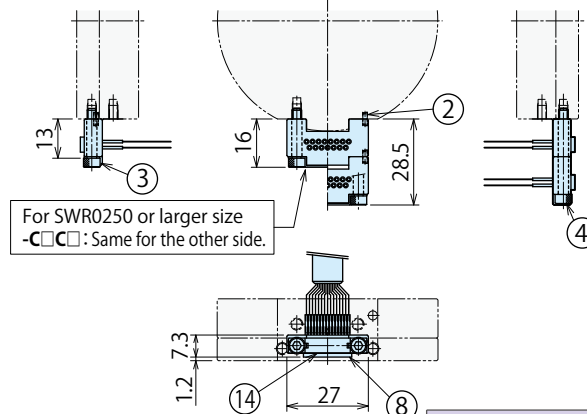

For SWR0250 or larger size
-C□C□ : Same for the other side.

Model No.	No.	Name	Quantity	
			C□ 15 poles	C□C□ : 30 poles SWR0120 or smaller SWR0250 or larger
SWRZ0C0 -M01/M02	①	Electrode (Master Side)	1	2
	②	Parallel Pin φ1.5×4 B Type (SUS)	2	4
4SW101785-00 ※2	⑭	Bolt Cover	1	1 2
	※2 ③	Hexagon Socket Bolt M3×0.5×16(SUS)	2	- 4
	※2 ④	Hexagon Socket Bolt M3×0.5×30(SUS)	-	2 -

Model No.	No.	Name	Quantity	
			C□ 15 poles	C□C□ : 30 poles SWR0120 or smaller SWR0250 or larger
SWRZ0C0 -T01/T02	⑧	Electrode (Tool Side)	1	2
	②	Parallel Pin φ1.5×4 B Type (SUS)	2	4
4SW101785-00 ※2	⑭	Bolt Cover	1	1 2
	※2 ③	Hexagon Socket Bolt M3×0.5×16(SUS)	2	- 4
	※2 ④	Hexagon Socket Bolt M3×0.5×30(SUS)	-	2 -

Notes : 1. Inform us with the model number shown above if you require an electrode only. (SWRZ0C0-□ : one set is one electrode.)

For SWRZ0C0-M□ / SWRZ050-M, the bolt and bolt cover marked with ※2 are not included.

2. The connected part of the solder terminal and lead wire is isolated with a thermal contraction tube.

3. For SWRZ0C0-□01/02 the lead wire length is different from its shown in the specifications.

(SWRZ0C0-□01 : Lead Wire Length 1m, SWRZ0C0-□02 : Lead Wire Length 2m)

External Dimensions (SWR0030)

Locating + Clamp
Locating
Hand • Clamp
Support
Valve • Coupler
Cautions • Others

Robotic Hand Changer

SWR Payload 3kg ~ 360kg

SWR010 Payload 0.5kg ~ 1kg

Manual Robotic Hand Changer

SXR

Pneumatic Location Clamp

SWT

Compact Pneumatic Location Clamp

SWQ

High-Power Pneumatic Pallet Clamp

WVS

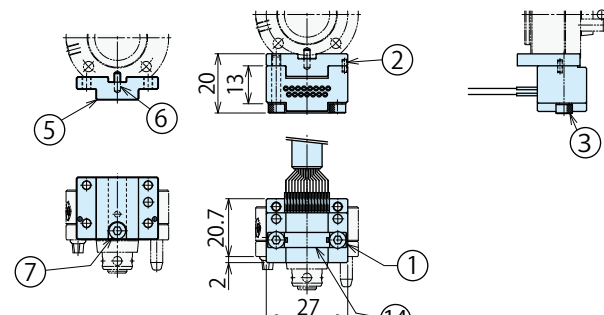
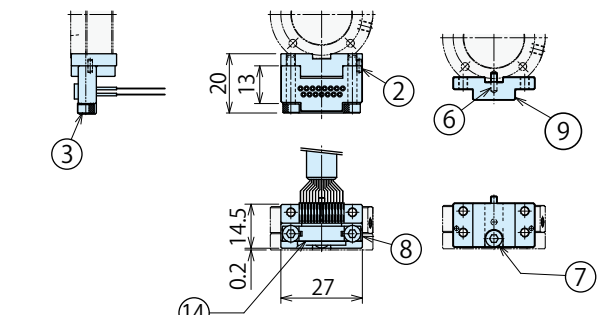
Master Cylinder Side				Tool Adapter Side				
SWR0030-M-C□ ※ Only for SWR0030-M-C□, SWRZ050-M is mounted.				SWR0030-T-C□ ※ Only for SWR0030-T-C□, SWRZ050-T is mounted.				
								
Model No.	No.	Name	Quantity	Model No.	No.	Name	Quantity	
SWRZ0C0 -M01/M02	①	Electrode (Master Side)	1	SWRZ0C0	⑧	Electrode (Tool Side)	1	
	②	Parallel Pin φ1.5×4 B Type (SUS)	2	-T01/T02	②	Parallel Pin φ1.5×4 B Type (SUS)	2	
	4SW101785-00 ※2	⑭	Bolt Cover	1	4SW101785-00 ※2	⑭	Bolt Cover	1
	- ※2	③	Hexagon Socket Bolt M3×0.5×16 (SUS)	2	- ※2	③	Hexagon Socket Bolt M3×0.5×16 (SUS)	2
SWRZ050-M	⑤	Bracket (Master Side)	1	SWRZ050-T	⑨	Bracket (Tool Side)	1	
	⑥	Parallel Pin φ2×6 B Type (SUS)	1		⑥	Parallel Pin φ2×6 B Type (SUS)	1	
	⑦	Hexagon Socket Bolt M3×0.5×6 (SUS)	1		⑦	Hexagon Socket Bolt M3×0.5×6 (SUS)	1	

- Notes : 1. Inform us with the model number shown above if you require an electrode only. (SWRZ0C0-□ : one set is one electrode.)
 For SWRZ0C0-M□ / SWRZ050-M / SWRZ0C0-T□ / SWRZ050-T, the bolt and bolt cover marked with ※2 are not included.
 2. The connected part of the solder terminal and lead wire is isolated with a thermal contraction tube.
 3. For SWRZ0C0-□01/02 the lead wire length is different from its shown in the specifications.
 (SWRZ0C0-□01 : Lead Wire Length 1m, SWRZ0C0-□02 : Lead Wire Length 2m)

External Dimensions (SWR1200)

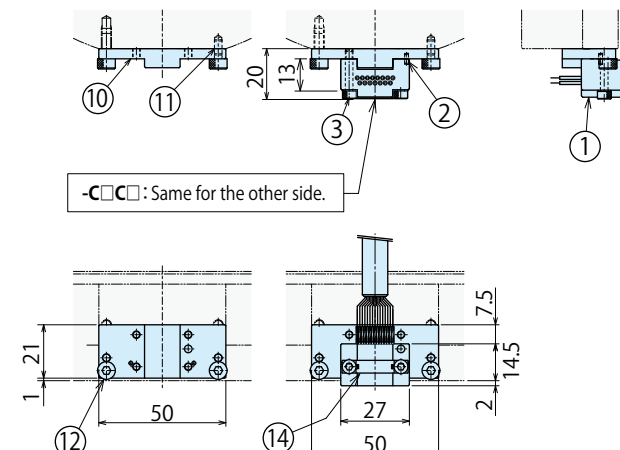
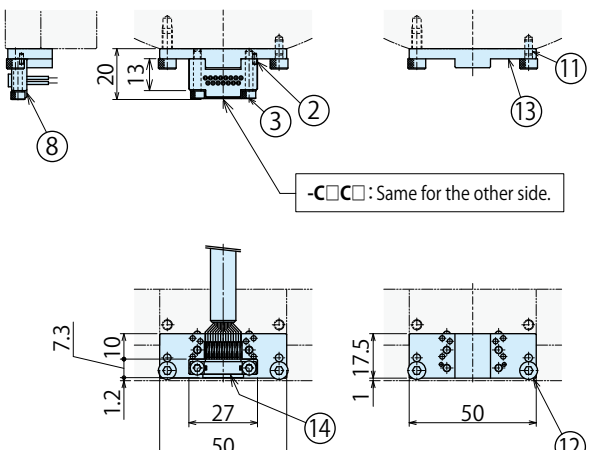
Master Cylinder Side				Tool Adapter Side				
SWR1200-MAF-C□/C□C□ ※ Only for SWR1200-MAF-C□/C□C□, SWRZ0B0-120MB is mounted.				SWR1200-T-C□/C□C□ ※ Only for SWR1200-T-C□/C□C□, SWRZ0B0-120TB is mounted.				
								
Model No.	No.	Name	Quantity	Model No.	No.	Name	Quantity	
SWRZ0C0 -M01/M02	①	Electrode (Master Side)	1 2	SWRZ0C0	⑧	Electrode (Tool Side)	1 2	
	②	Parallel Pin φ1.5×4 B Type (SUS)	1 4	-T01/T02	②	Parallel Pin φ1.5×4 B Type (SUS)	2 4	
	4SW101785-00 ※2	⑭	Bolt Cover	1 2	4SW101785-00 ※2	⑭	Bolt Cover	1 2
	- ※2	③	Hexagon Socket Bolt M3×0.5×16 (SUS)	2 4	- ※2	③	Hexagon Socket Bolt M3×0.5×16 (SUS)	2 4
SWRZ0B0-120MB	⑩	Bracket (Master Side)	1 2	SWRZ0B0-120TB	⑬	Bracket (Tool Side)	1 2	
	⑪	Parallel Pin φ3×6 B Type (SUS)	2 4		⑪	Parallel Pin φ3×6 B Type (SUS)	2 4	
	⑫	Hexagon Socket Bolt M4×0.7×10 (SUS)	2 4		⑫	Hexagon Socket Bolt M4×0.7×10 (SUS)	2 4	

- Notes : 1. Inform us with the model number shown above if you require an electrode only. (SWRZ0C0-□ : one set is one electrode.)
 For SWRZ0C0-M□ / SWRZ0B0-120MB / SWRZ0C0-T□ / SWRZ0B0-120TB, the bolt and bolt cover marked with ※2 are not included.
 2. The connected part of the solder terminal and lead wire is isolated with a thermal contraction tube.
 3. For SWRZ0C0-□01/02 the lead wire length is different from its shown in the specifications.
 (SWRZ0C0-□01 : Lead Wire Length 1m, SWRZ0C0-□02 : Lead Wire Length 2m)

External Option : Solder Terminal with Cable (Continued)

External Option Symbol : C01/C02

Master Cylinder
model SWR □ 0-M □ -

C01
C02



Tool Adapter
model SWR □ 0-T □ -

C01
C02



Pin Numbers

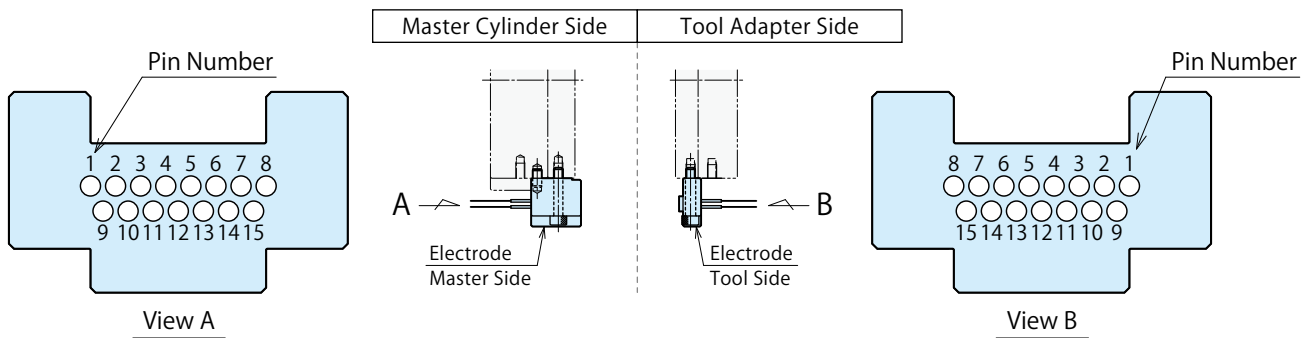

【 Important 】 Announcement of Cable Specification Change

We are using the new robot cable due to its performance and flexibility improvement. Please make sure to check the specifications of the new cable shown on the next page.



Current Cable

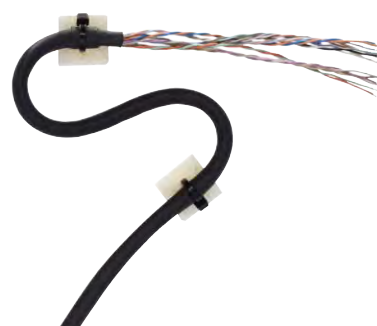

New Cable

Scheduled to change in April, 2020. (Replacement period is subject to change due to the stock condition.)

Pin Numbers and Wire Colors

[Important] Wire colors of the new cable and the current cable are different.

New Cable

HIFLON SD-SB/20276 Black AWG24X8P (with Shield)
 NISSEI ELECTRIC Weight : 76g /m (Weight per meter)
 Conductor Cross-Sectional Area : 0.2mm² (AWG24)
 Number of Cores : 16



Pin Number	1	2	3	4	5	6	7	8	9	10	11	12	13	14	15	Not Used
Wire Color	Black	White	Red	Green	Yellow	Brown	Blue	Orange	Gray	Violet	Light Blue	Pink	White/Black	White/Red	White/Blue	Yellow/Black
	Twisted Pair		Twisted Pair		Twisted Pair		Twisted Pair		Twisted Pair		Twisted Pair		Twisted Pair		Twisted Pair	

Current Cable

ORP—0.2SQX8P(SB) (2464) (with Shield)
 Oki Electric Cable Weight : 101g /m (Weight per meter)
 Conductor Cross-Sectional Area : 0.2mm² (AWG25)
 Number of Cores : 16



Pin Number	1	2	3	4	5	6	7	8	9	10	11	12	13	14	15	Not Used
Wire Color	Blue	White	Yellow	Brown	Green	Black	Red	Gray	Violet	Orange	Blue	Brown	Yellow	Black	Green	Gray
	Twisted Pair		Twisted Pair		Twisted Pair		Twisted Pair		Twisted Pair		Twisted Pair		Twisted Pair		Twisted Pair	

- Locating + Clamp
- Locating
- Hand - Clamp
- Support
- Valve - Coupler
- Cautions - Others

- Robotic Hand Changer
 - SWR Payload 3kg ~ 360kg
 - SWR0010 Payload 0.5kg ~ 1kg

- Manual Robotic Hand Changer
 - SXR

- Pneumatic Location Clamp
 - SWT

- Compact Pneumatic Location Clamp
 - SWQ

- High-Power Pneumatic Pallet Clamp
 - WVS

External Option : Waterproof Electrode (Simple Waterproof Option)

External Option Symbol : U01/U02

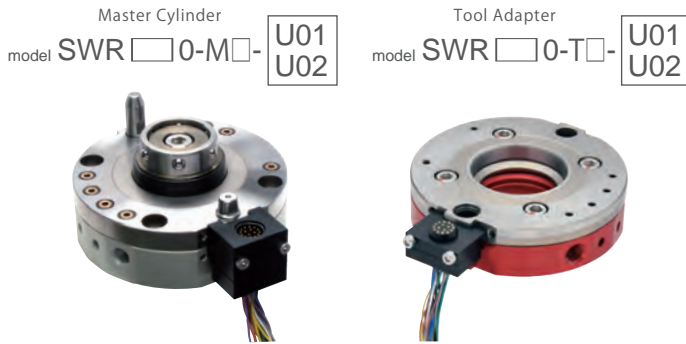

Specifications

Rated Value (per contact)	DC 24V 3A
Contact Resistance (Initial Value)	100mΩ or less
Total Current Capacity	10A
Number of Poles (per electrode)	16
Lead Wire Size	Refer to P.49 and P.50
Lead Wire Length	-U01 : 1m -U02 : 2m
Weight ※1	Master Cylinder Side Electrode - U01 : 140g / -U02 : 260g Bracket for SWR0030-M : 10g Bracket for SWR1200-M : 18g
	Tool Adapter Side Electrode - U01 : 140g / -U02 : 250g Bracket for SWR0030-T : 8g Bracket for SWR1200-T : 16g
Protection Grade ※2	Equivalent to IP54

※1. Weight per electrode. Bracket weight shows the weight of SWRZ050-□, SWRZ080-120□B.
 ※2. The protection grade is equivalent to IP54 at connected state (fit state) of the master cylinder and tool adapter.

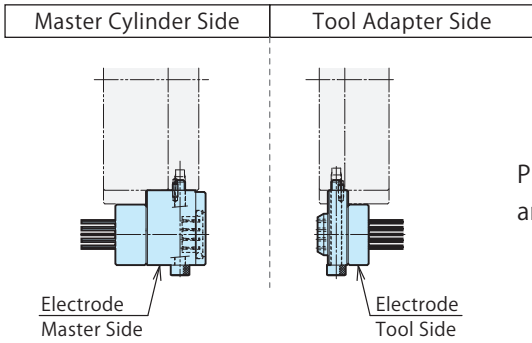

Please refer to P.49 and P.50 for the pin numbers, the wire colors and the cable specifications.

External Dimensions (SWR0070/SWR0120/SWR0250/SWR0500/SWR0750/SWR2300)

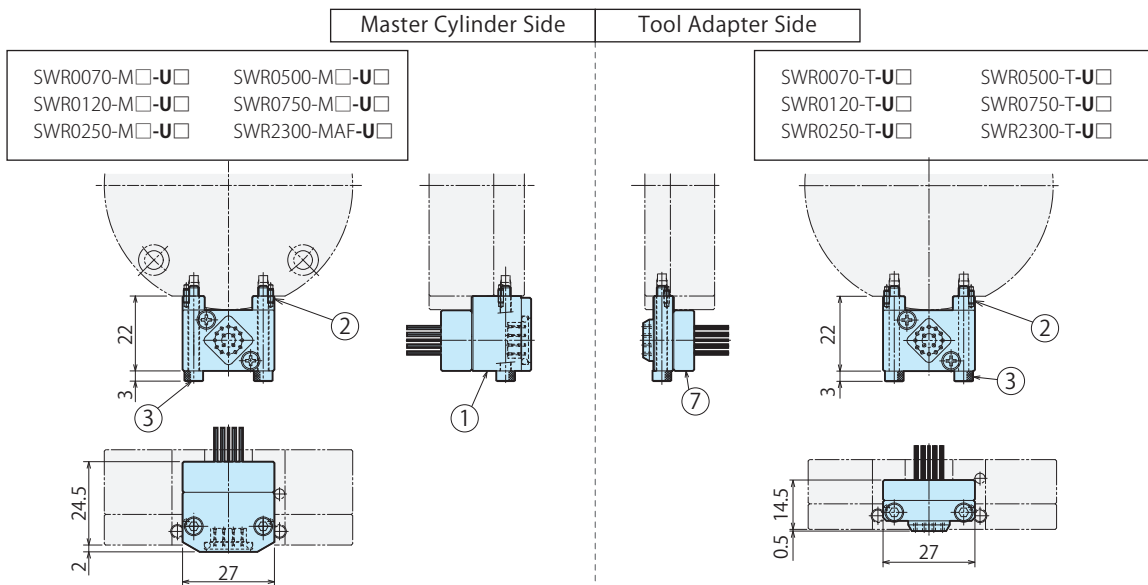

Model No.	No.	Name	Quantity
SWRZ0U0 -M01/M02	①	Electrode (Master Side)	1
	②	Parallel Pin φ1.5×4 B Type (SUS)	2
	③	Hexagon Socket Bolt M3×0.5×25 (SUS)	2

Model No.	No.	Name	Quantity
SWRZ0U0 -T01/T02	⑦	Electrode (Tool Side)	1
	②	Parallel Pin φ1.5×4 B Type (SUS)	2
	③	Hexagon Socket Bolt M3×0.5×25 (SUS)	2

Notes : 1. Inform us with the model number shown above if you require an electrode only. (SWRZ0U0-□ : one set is one electrode.)
 2. For SWRZ0U0-□01/02 the lead wire length is different from its shown in the specifications.
 (SWRZ0U0-□01 : Lead Wire Length 1m, SWRZ0U0-□02 : Lead Wire Length 2m)

External Dimensions (SWR0030)

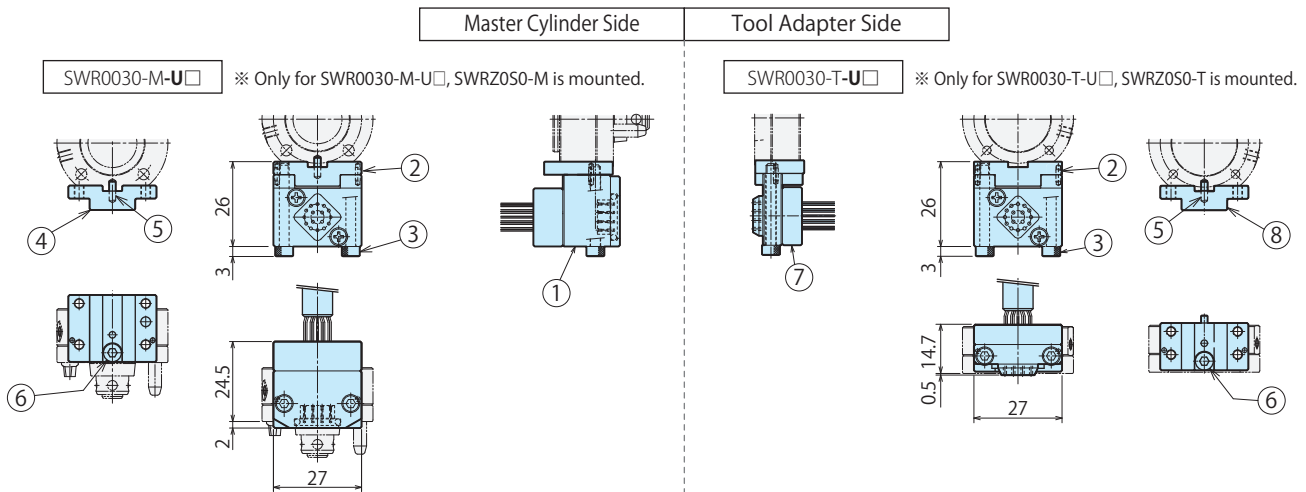

Model No.	No.	Name	Quantity
SWRZ0U0 -M01/M02	①	Electrode (Master Side)	1
	②	Parallel Pin φ1.5×4 B Type (SUS)	2
	③	Hexagon Socket Bolt M3×0.5×25 (SUS)	2
SWRZ050-M	④	Bracket (Master Side)	1
	⑤	Parallel Pin φ2×6 B Type (SUS)	1
	⑥	Hexagon Socket Bolt M3×0.5×6 (SUS)	1

Model No.	No.	Name	Quantity
SWRZ0U0 -T01/T02	⑦	Electrode (Tool Side)	1
	②	Parallel Pin φ1.5×4 B Type (SUS)	2
	③	Hexagon Socket Bolt M3×0.5×25 (SUS)	2
SWRZ050-T	⑧	Bracket (Tool Side)	1
	⑤	Parallel Pin φ2×6 B Type (SUS)	1
	⑥	Hexagon Socket Bolt M3×0.5×6 (SUS)	1

Notes : 1. Inform us with the model number shown above if you require an electrode only. (SWRZ0U0-□ : one set is one electrode.)
 2. For SWRZ0U0-□01/02 the lead wire length is different from its shown in the specifications.
 (SWRZ0U0-□01 : Lead Wire Length 1m, SWRZ0U0-□02 : Lead Wire Length 2m)

External Dimensions (SWR1200)

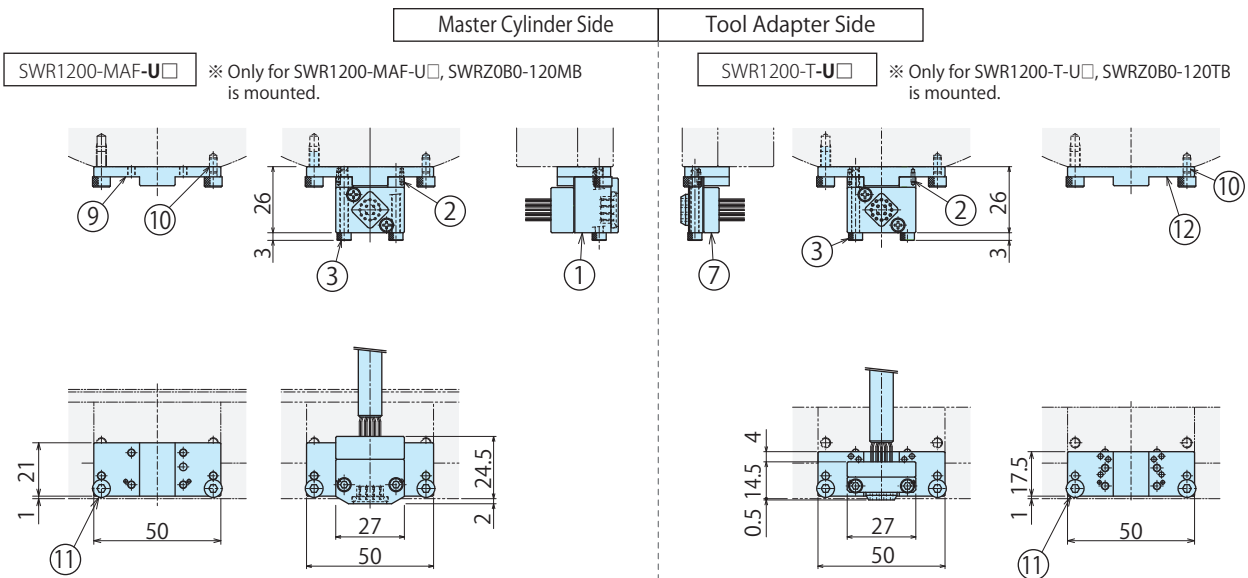

Model No.	No.	Name	Quantity
SWRZ0U0 -M01/M02	①	Electrode (Master Side)	1
	②	Parallel Pin φ1.5×4 B Type (SUS)	2
	③	Hexagon Socket Bolt M3×0.5×25 (SUS)	2
SWRZ0B0-120MB	⑨	Bracket (Master Side)	1
	⑩	Parallel Pin φ3×6 B Type (SUS)	2
	⑪	Hexagon Socket Bolt M4×0.7×10 (SUS)	2

Model No.	No.	Name	Quantity
SWRZ0U0 -T01/T02	⑦	Electrode (Tool Side)	1
	②	Parallel Pin φ1.5×4 B Type (SUS)	2
	③	Hexagon Socket Bolt M3×0.5×25 (SUS)	2
SWRZ0B0-120TB	⑫	Bracket (Tool Side)	1
	⑩	Parallel Pin φ3×6 B Type (SUS)	2
	⑪	Hexagon Socket Bolt M4×0.7×10 (SUS)	2

Notes : 1. Inform us with the model number shown above if you require an electrode only. (SWRZ0U0-□ : one set is one electrode.)
 2. For SWRZ0U0-□01/02 the lead wire length is different from its shown in the specifications.
 (SWRZ0U0-□01 : Lead Wire Length 1m, SWRZ0U0-□02 : Lead Wire Length 2m)

Locating + Clamp
Locating
Hand • Clamp
Support
Valve • Coupler
Cautions • Others
Robotic Hand Changer
SWR Payload 3kg ~ 360kg
SWR0010 Payload 0.5kg ~ 1kg
Manual Robotic Hand Changer
SXR
Pneumatic Location Clamp
SWT
Compact Pneumatic Location Clamp
SWQ
High-Power Pneumatic Pallet Clamp
WVS

External Option : Waterproof Electrode (Simple Waterproof Option)

External Option Symbol : U01/U02

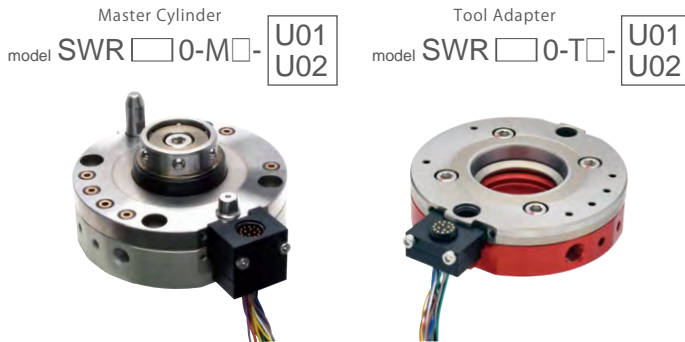

Pin Numbers

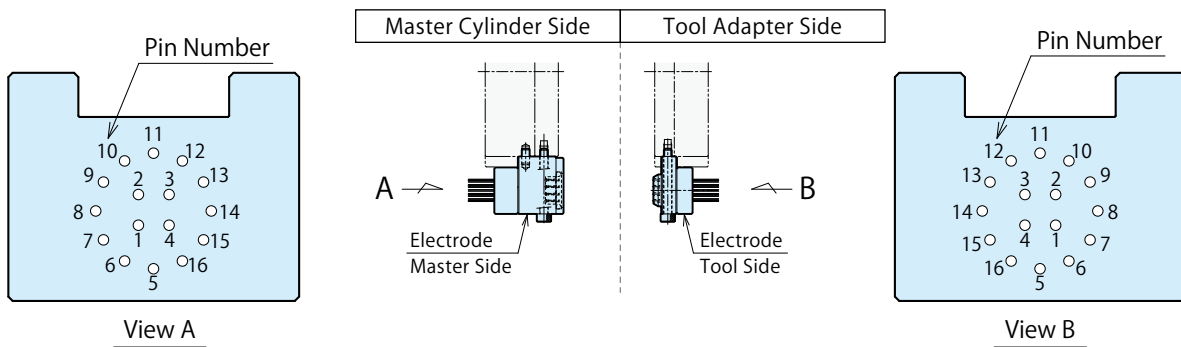

【 Important 】 Announcement of Cable Specification Change

We are using the new robot cable due to its performance and flexibility improvement. Please make sure to check the specifications of the new cable shown on the next page.

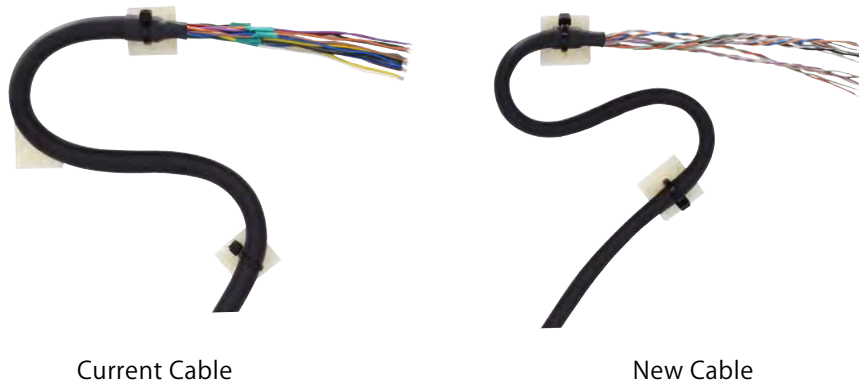

Scheduled to change in April, 2020. (Replacement period is subject to change due to the stock condition.)

Pin Numbers and Wire Colors

[Important] Wire colors of the new cable and the current cable are different.

New Cable

HIFLON SD-SB/20276 Black AWG24X8P (with Shield)
 NISSEI ELECTRIC Weight : 76g /m (Weight per meter)
 Conductor Cross-Sectional Area : 0.2mm² (AWG24)
 Number of Cores : 16



Pin Number	1	2	3	4	5	6	7	8	9	10	11	12	13	14	15	16
Wire Color	Black	White	Red	Green	Yellow	Brown	Blue	Orange	Gray	Violet	Light Blue	Pink	White/Black	White/Red	White/Blue	Yellow/Black
	Twisted Pair		Twisted Pair		Twisted Pair		Twisted Pair		Twisted Pair		Twisted Pair		Twisted Pair		Twisted Pair	

Current Cable

ORP—0.2SQX8P(SB) (2464) (with Shield)
 Oki Electric Cable Weight : 101g /m (Weight per meter)
 Conductor Cross-Sectional Area : 0.2mm² (AWG25)
 Number of Cores : 16

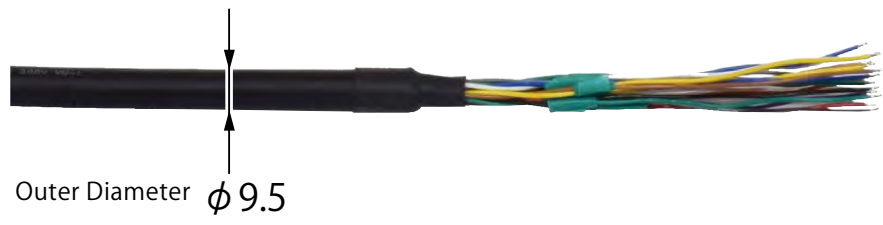

Pin Number	1	2	3	4	5	6	7	8	9	10	11	12	13	14	15	16
Wire Color	Blue	White	Yellow	Brown	Green	Black	Red	Gray	Violet	Orange	Blue	Brown	Yellow	Black	Green	Gray
	Twisted Pair		Twisted Pair		Twisted Pair		Twisted Pair		Twisted Pair		Twisted Pair		Twisted Pair		Twisted Pair	

- Locating + Clamp
- Locating
- Hand - Clamp
- Support
- Valve - Coupler
- Cautions - Others

- Robotic Hand Changer
 - SWR Payload 3kg ~ 360kg
 - SWR0010 Payload 0.5kg ~ 1kg

- Manual Robotic Hand Changer
 - SXR

- Pneumatic Location Clamp
 - SWT

- Compact Pneumatic Location Clamp
 - SWQ

- High-Power Pneumatic Pallet Clamp
 - WVS

External Option : D-SUB Connector

External Option Symbol : D



Specifications

Rated Value (per contact)	DC 24V 3A	
Contact Resistance (Initial Value)	100mΩ or less	
Total Current Capacity	10A	
Number of Poles (per electrode)	15	
Weight ※1	Master Cylinder Side	Electrode 80g / Bracket 17g
	Tool Adapter Side	Electrode 70g / Bracket 17g

※1. Weight per electrode.
Bracket weight shows the weight of SWRZ0Z0.

External Dimensions

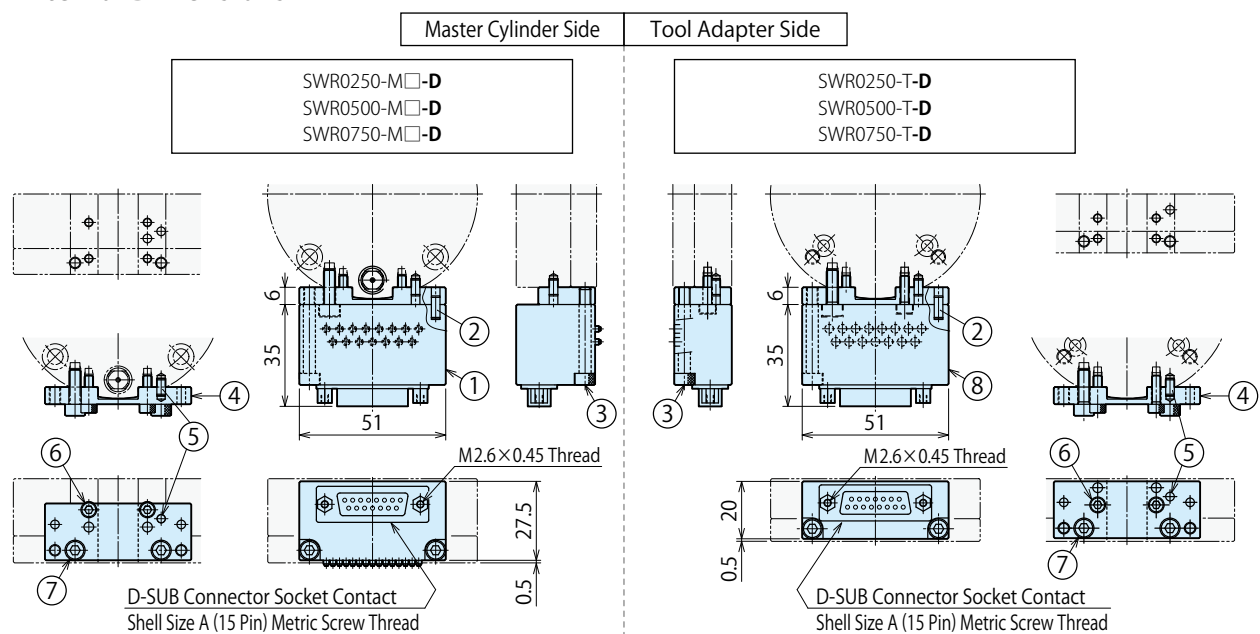

SWR1200-MAF-D
SWR2300-MAF-D ※ Unlisted dimensions are the same as the drawing above.

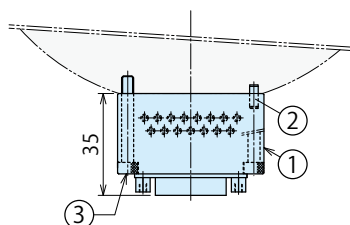

SWR1200-T-D
SWR2300-T-D ※ Unlisted dimensions are the same as the drawing above.

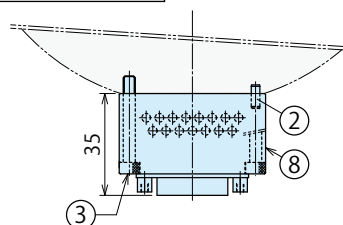

Model No.	No.	Name	Quantity
SWRZ0D0-M	①	Electrode (Master Side)	1
	②	Parallel Pin $\phi 3 \times 8$ B Type (SUS)	2
	③	Hexagon Socket Bolt M4×0.7×30 (SUS)	2
SWRZ0Z0	④	Bracket (Common for Master/Tool Side)	1
	⑤	Parallel Pin $\phi 3 \times 8$ B Type (SUS)	1
	⑥	Hexagon Socket Bolt M3×0.5×10 (SUS)	2
	⑦	Hexagon Socket Bolt M4×0.7×12 (SUS)	2

Model No.	No.	Name	Quantity
SWRZ0D0-T	⑧	Electrode (Tool Side)	1
	②	Parallel Pin $\phi 3 \times 8$ B Type (SUS)	2
	③	Hexagon Socket Bolt M4×0.7×30 (SUS)	2
SWRZ0Z0	④	Bracket (Common for Master/Tool Side)	1
	⑤	Parallel Pin $\phi 3 \times 8$ B Type (SUS)	1
	⑥	Hexagon Socket Bolt M3×0.5×10 (SUS)	2
	⑦	Hexagon Socket Bolt M4×0.7×12 (SUS)	2

Notes : 1. Inform us with the model number shown above if you require an electrode only. (SWRZ0D0-□ : one set is one electrode.)
2. For SWR1200/SWR2300, SWRZ0Z0 is not required.

External Option : Circular Connector (Connector Based on JIS C 5432)

External Option Symbol : G



Specifications

Rated Value (per contact)	DC 24V 3A
Contact Resistance (Initial Value)	100mΩ or less
Total Current Capacity	17A
Number of Poles (per electrode)	15
Weight※1	Master Cylinder Side Electrode 100g / Bracket 21g
	Tool Adapter Side Electrode 120g / Bracket 21g

※1. Weight per electrode.

Bracket weight shows the weight of SWRZ0E0.

External Dimensions

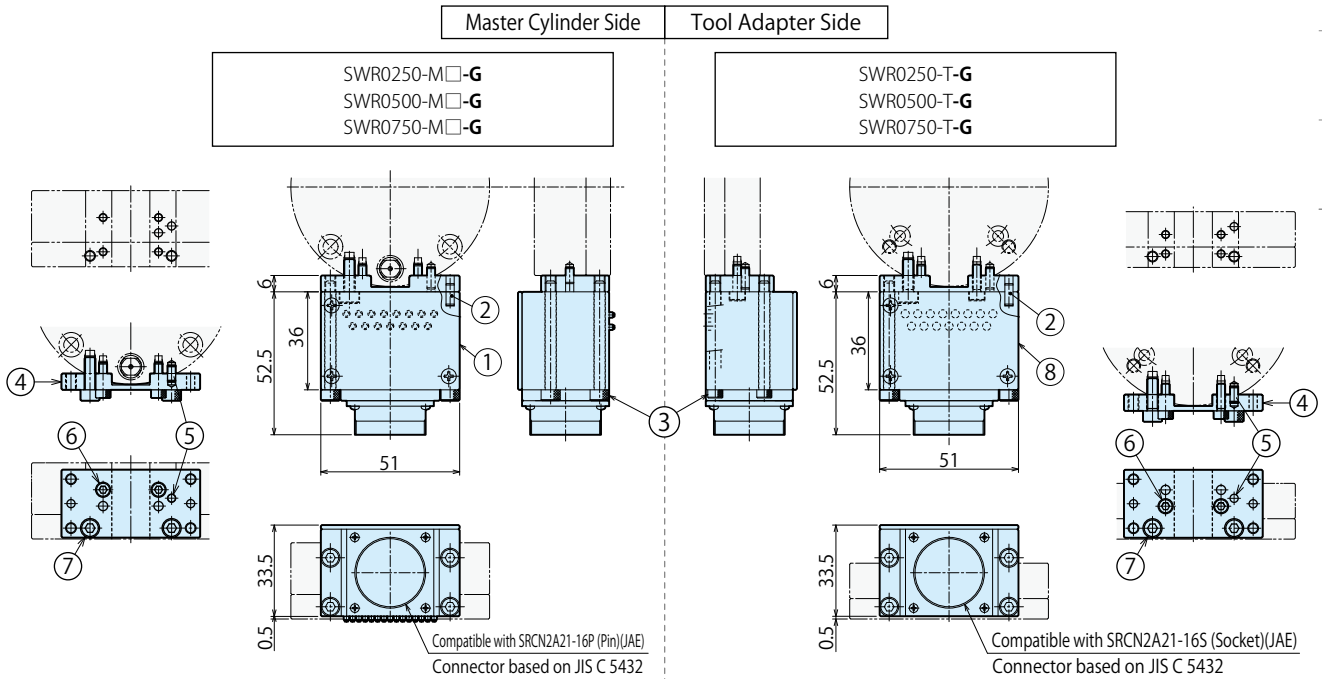

SWR1200-MAF-G
SWR2300-MAF-G ※ Unlisted dimensions are the same as the drawing above.

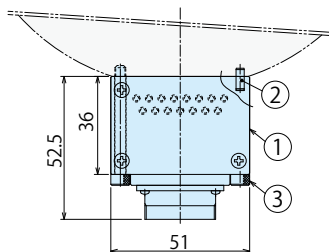

SWR1200-T-G
SWR2300-T-G ※ Unlisted dimensions are the same as the drawing above.

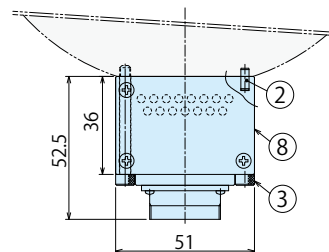

Model No.	No.	Name	Quantity
SWRZ0G0-M	①	Electrode (Master Side)	1
	②	Parallel Pin $\phi 3 \times 8$ B Type (SUS)	2
	③	Hexagon Socket Bolt M4×0.7×40 (SUS)	4
SWRZ0E0	④	Bracket (Common for Master/Tool Side)	1
	⑤	Parallel Pin $\phi 3 \times 6$ B Type (SUS)	1
	⑥	Hexagon Socket Bolt M3×0.5×10 (SUS)	2
	⑦	Hexagon Socket Bolt M4×0.7×12 (SUS)	2

Model No.	No.	Name	Quantity
SWRZ0G0-T	⑧	Electrode (Tool Side)	1
	②	Parallel Pin $\phi 3 \times 8$ B Type (SUS)	2
	③	Hexagon Socket Bolt M4×0.7×40 (SUS)	4
SWRZ0E0	④	Bracket (Common for Master/Tool Side)	1
	⑤	Parallel Pin $\phi 3 \times 6$ B Type (SUS)	1
	⑥	Hexagon Socket Bolt M3×0.5×10 (SUS)	2
	⑦	Hexagon Socket Bolt M4×0.7×12 (SUS)	2

Notes : 1. Inform us with the model number shown above if you require an electrode only. (SWRZ0G0-□ : one set is one electrode.)
2. For SWR1200/SWR2300, SWRZ0E0 is not required.

Locating
+
Clamp

Locating

Hand · Clamp

Support

Valve · Coupler

Cautions · Others

Robotic
Hand Changer

SWR
Payload
3kg ~ 360kg

SWR0010
Payload
0.5kg ~ 1kg

Manual Robotic
Hand Changer

SXR

Pneumatic
Location Clamp

SWT

Compact Pneumatic
Location Clamp

SWQ

High-Power Pneumatic
Pallet Clamp

WVS

External Option : Compact Electric Power Transmission

Extendible Options : Resin Connector, Solder Terminal

External Option Symbol : K

Master Cylinder
model SWR □ 0-M □

K
or
Model No. for
Extendible Option

Tool Adapter
model SWR □ 0-T □

K
or
Model No. for
Extendible Option



Specifications

Rated Value (per contact)	AC/DC 200V 5A
Total Current Capacity	12A
Number of Poles (per electrode)	4
Weight*1	Master Cylinder Side Electrode 17g Bracket for SWR0030-M : 10g
	Tool Adapter Side Electrode 13g Bracket for SWR0030-T : 8g
Cable with Applicable Terminal (Sold Separately)	SWZ0K0-CL □ (Refer to P.55)

*1. Weight per electrode.
Bracket weight shows the weight of SWR2050-□.

Extendible Options Additional electrode can be extended to the option : K.

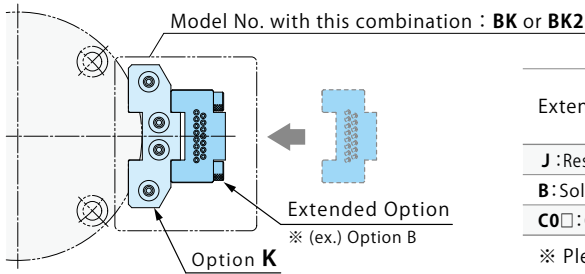

Extendable Electrode	Model No. for Extendible Option						
	SWR 0030	SWR 0070	SWR 0120	SWR 0250	SWR 0500	SWR 0750	SWR 2300
J : Resin Connector		JK	JK	JK2	JK2	JK2	JK2
B : Solder Terminal	N/A	BK	BK	BK2	BK2	BK2	BK2
CO □ : Cable with Solder Terminal		CO □ K	CO □ K	CO □ K2	CO □ K2	CO □ K2	CO □ K2

* Please contact us for detailed dimensions for extendible options.

Applicable Cable

The cable with applicable terminal and applicable terminal are not included.

Please prepare the cable with applicable terminal (SWZ0K0-CL □) on P.55 or design it yourself referring to the applicable terminal on P.55.

External Dimensions (SWR0070/SWR0120/SWR0250/SWR0500/SWR0750/SWR2300)

Master Cylinder Side				Tool Adapter Side			
SWR0070-M □ -K	SWR0120-M □ -K	SWR0250-M □ -K	SWR0500-M □ -K	SWR0070-T-K	SWR0120-T-K	SWR0250-T-K	SWR0500-T-K
SWR0750-M □ -K	SWR2300-MAF-K			SWR0750-T-K	SWR2300-T-K		

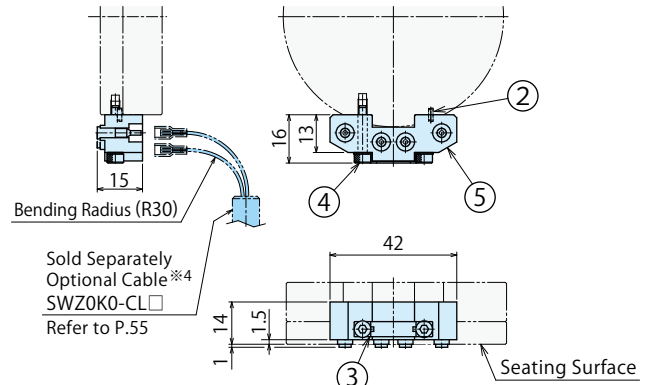
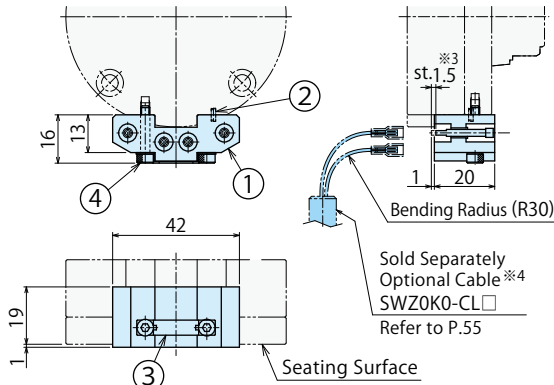

Model No.	No.	Name	Quantity
SWRZ0K0-M	①	Electrode (Master Side)	1
	②	Parallel Pin φ 1.5×4 B Type (SUS)	2
45W101785-00 ※2	③	Bolt Cover	1
- ※2	④	Hexagon Socket Bolt M3×0.5×16 (SUS)	2

Model No.	No.	Name	Quantity
SWRZ0K0-T	⑤	Electrode (Tool Side)	1
	②	Parallel Pin φ 1.5×4 B Type (SUS)	2
45W101785-00 ※2	③	Bolt Cover	1
- ※2	④	Hexagon Socket Bolt M3×0.5×16 (SUS)	2

Notes : 1. Inform us with the model number shown above if you require an electrode only. (SWRZ0K0-□ : one set is one electrode.)

For SWRZ0K0-M / SWRZ0K0-T, the bolt and bolt cover marked with ※2 are not included.

2. The electrode probe on master side strokes 1.5mm (※3) when connecting with SWR.
When fixing the cable, make sure there is enough space for the probe operation.

3. The electrode stays connected when released, because its connecting stroke requires 1.5mm which is longer than SWR lift stroke.

※4. The optional cable and terminal are not included in the electrode. Please prepare them separately.

● External Dimensions (SWR0030)

Locating + Clamp
Locating
Hand + Clamp
Support
Valve + Coupler
Cautions + Others
Robotic Hand Changer
SWR Payload 3kg ~ 360kg
SWR0010 Payload 0.5kg ~ 1kg
Manual Robotic Hand Changer
SXR
Pneumatic Location Clamp
SWT
Compact Pneumatic Location Clamp
SWQ
High-Power Pneumatic Pallet Clamp
WVS

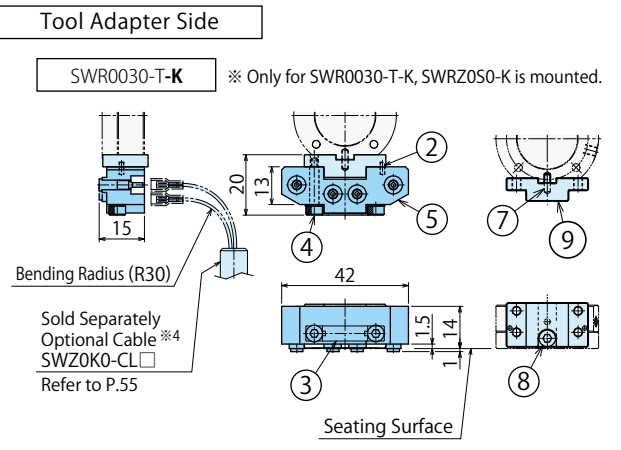
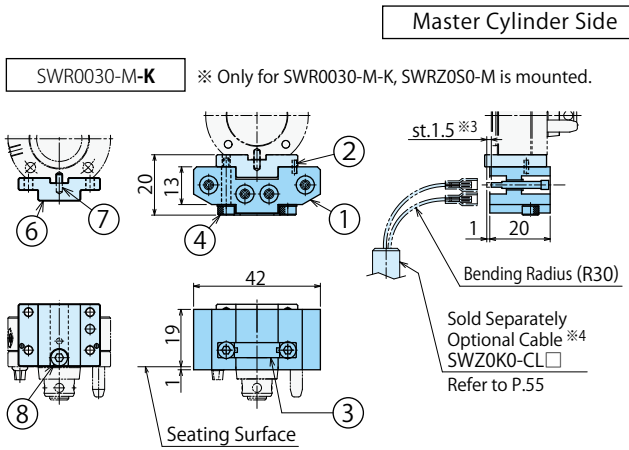

Model No.	No.	Name	Quantity
SWRZ0K0-M	①	Electrode (Master Side)	1
	②	Parallel Pin $\phi 1.5 \times 4$ B Type (SUS)	2
	③	Bolt Cover	1
	④	Hexagon Socket Bolt M3 \times 0.5 \times 16 (SUS)	2
4SW101785-00 ※2	⑤	Bolt Cover	1
	⑥	Bracket (Master Side)	1
	⑦	Parallel Pin $\phi 2 \times 6$ B Type (SUS)	1
	⑧	Hexagon Socket Bolt M3 \times 0.5 \times 6 (SUS)	1

Model No.	No.	Name	Quantity
SWRZ0K0-T	⑤	Electrode (Tool Side)	1
	②	Parallel Pin $\phi 1.5 \times 4$ B Type (SUS)	2
	③	Bolt Cover	1
	④	Hexagon Socket Bolt M3 \times 0.5 \times 16 (SUS)	2
4SW101785-00 ※2	⑥	Bracket (Tool Side)	1
	⑦	Parallel Pin $\phi 2 \times 6$ B Type (SUS)	1
	⑧	Hexagon Socket Bolt M3 \times 0.5 \times 6 (SUS)	1

- Notes : 1. Inform us with the model number shown above if you require an electrode only. (**SWRZ0K0-□** : one set is one electrode.)
 For SWRZ0K0-M / SWRZ0K0-T / SWRZ050-M / SWRZ050-T, the bolt and bolt cover marked with ※2 are not included.
 2. The electrode probe on master side strokes 1.5mm (※3) when connecting with SWR.
 When fixing the cable, make sure there is enough space for the probe operation.
 3. The electrode stays connected when released, because its connecting stroke requires 1.5mm which is longer than SWR lift stroke.
 ※4. The optional cable and terminal are not included in the electrode. Please prepare them separately.

External Option : Cable with Terminal for Compact Electric Power Transmission

This cable is an optional cable applicable to the Compact Electric Power Transmission (SWR External Option Symbol : K).

Model No. Indication

SWZ0K0-C

L1
L2

Cable Length
L1 : 1m
L2 : 2m

Design No.
(Revision Number)

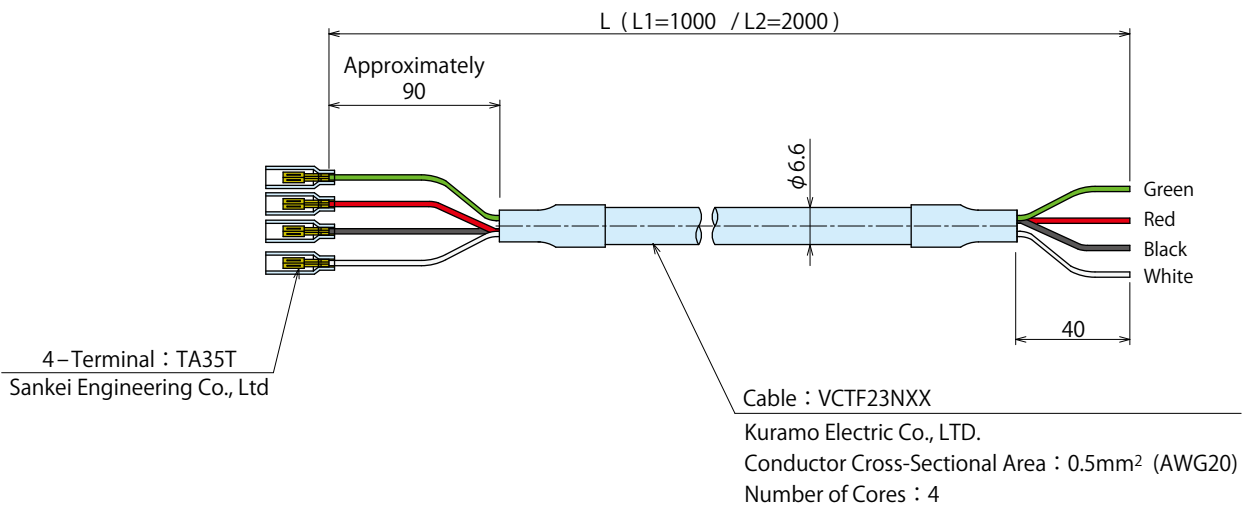

※ A crimp tool for crimping the applicable terminal (TA35T) is required when preparing a cable by yourself referring to this drawing.

【Notes on Wire/Cable Procedure and Wiring】

- Make sure to fix the wire and cable so that they are not pulled while a robot is moving or turning around. External force should not be applied on the connector part since it leads to breaking of wire, detaching of connector and contact failure. However, the electrode probe on master side strokes 1.5mm when connecting with SWR. When fixing the cable, make sure there is enough space for the probe to stroke.

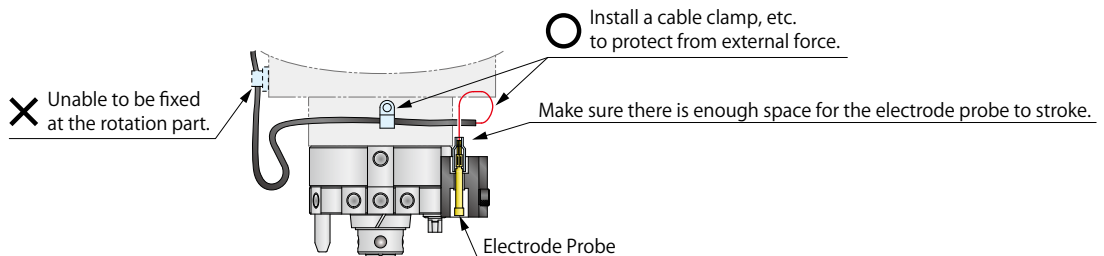

- As for Compact Electric Power Transmission option, the electrode probes on both master cylinder and tool adaptor are exchangeable. The electrode probes will be fallen out if pushed from the cable connecting side with power stronger than a certain level. In case the electrode probes are pushed out after connecting the cable, make sure to push them back from the seating surface side before use.

MEMO

- Locating + Clamp**
- Locating
- Hand • Clamp
- Support
- Valve • Coupler
- Cautions • Others

- Robotic Hand Changer**
- SWR Payload 3kg ~ 360kg**
- SWR010 Payload 0.5kg ~ 1kg
- Manual Robotic Hand Changer
- SXR
- Pneumatic Location Clamp
- SWT
- Compact Pneumatic Location Clamp
- SWQ
- High-Power Pneumatic Pallet Clamp
- WVS

External Option : Power Transmission Option (Connector Based on MIL-DTL-5015)

External Option Symbol : E



Specifications

Rated Value (per contact)	AC/DC 200V 5A	
Total Current Capacity	24A	
Number of Poles (per electrode)	8	
Weight ※1	Master Cylinder Side	Electrode 140g / Bracket 21g
	Tool Adapter Side	Electrode 150g / Bracket 21g

※1. Weight per electrode.
Bracket weight shows the weight of SWRZ0E0.

External Dimensions

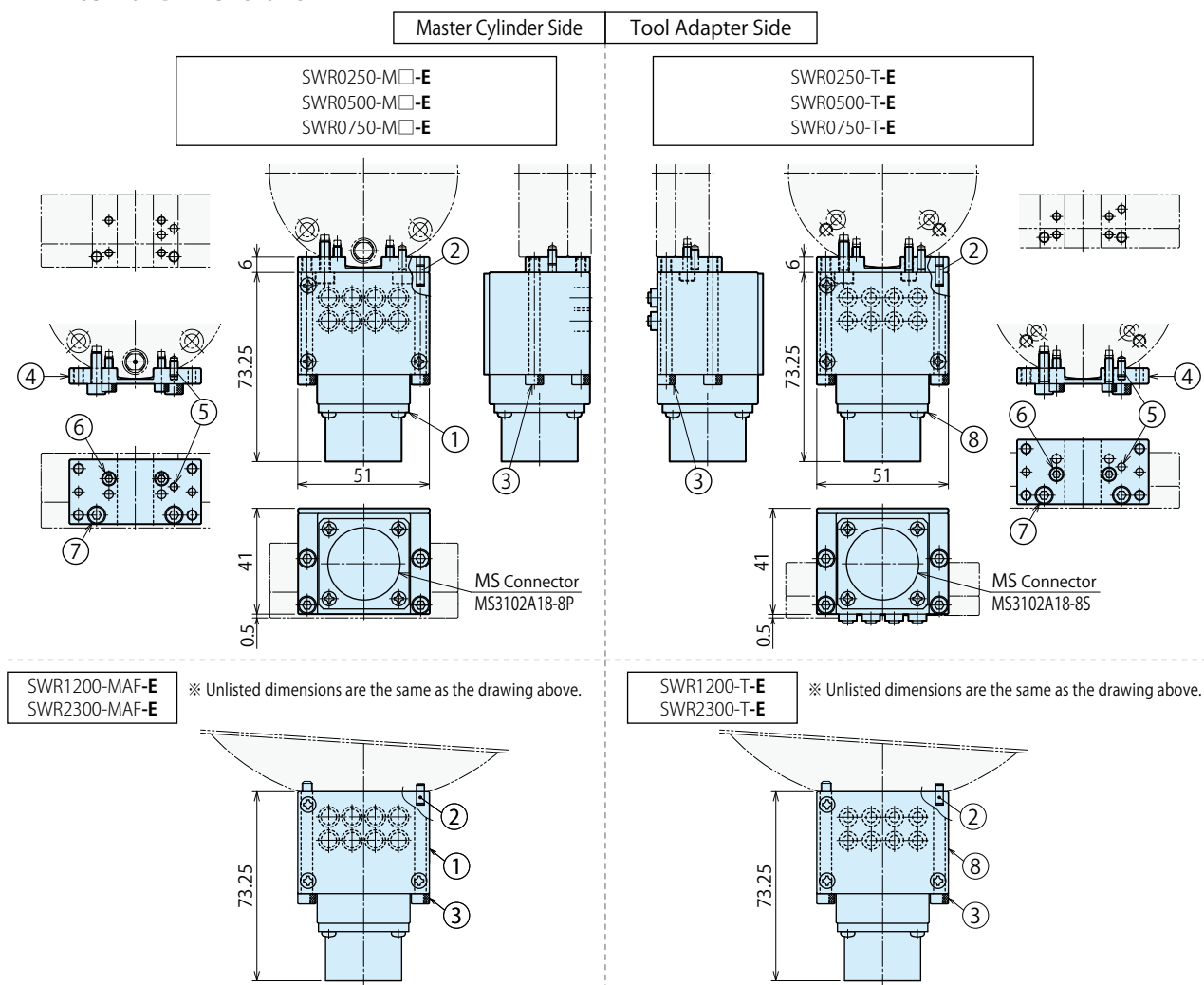

Model No.	No.	Name	Quantity
SWRZ0E0-M	①	Electrode (Master Side)	1
	②	Parallel Pin $\phi 3 \times 8$ B Type (SUS)	2
	③	Hexagon Socket Bolt M4 \times 0.7 \times 45 (SUS)	4
SWRZ0E0	④	Bracket (Common for Master/Tool Side)	1
	⑤	Parallel Pin $\phi 3 \times 6$ B Type (SUS)	1
	⑥	Hexagon Socket Bolt M3 \times 0.5 \times 10 (SUS)	2
	⑦	Hexagon Socket Bolt M4 \times 0.7 \times 12 (SUS)	2

Model No.	No.	Name	Quantity
SWRZ0E0-T	⑧	Electrode (Tool Side)	1
	②	Parallel Pin $\phi 3 \times 8$ B Type (SUS)	2
	③	Hexagon Socket Bolt M4 \times 0.7 \times 45 (SUS)	4
SWRZ0E0	④	Bracket (Common for Master/Tool Side)	1
	⑤	Parallel Pin $\phi 3 \times 6$ B Type (SUS)	1
	⑥	Hexagon Socket Bolt M3 \times 0.5 \times 10 (SUS)	2
	⑦	Hexagon Socket Bolt M4 \times 0.7 \times 12 (SUS)	2

Notes : 1. Inform us with the model number shown above if you require an electrode only. (SWRZ0E0-□ : one set is one electrode.)
2. For SWR1200/SWR2300, SWRZ0E0 is not required.

External Option : High Current Transmission Option (Connector Based on MIL-DTL-5015)

External Option Symbol : H

Master Cylinder
model SWR□□0-M□-H



Tool Adapter
model SWR□□0-T□-H

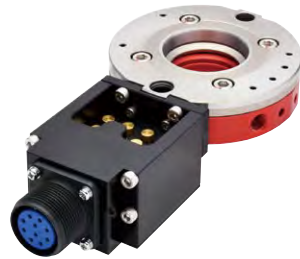

Specifications

Rated Value (per contact)	AC/DC 200V 13A
Total Current Capacity	57A
Number of Poles (per electrode)	10
Weight ※1	Master Cylinder Side Electrode 280g / Bracket 24g
	Tool Adapter Side Electrode 210g / Bracket 24g

※1. Weight per electrode.

Bracket weight shows the weight of SWRZ0H0.

External Dimensions

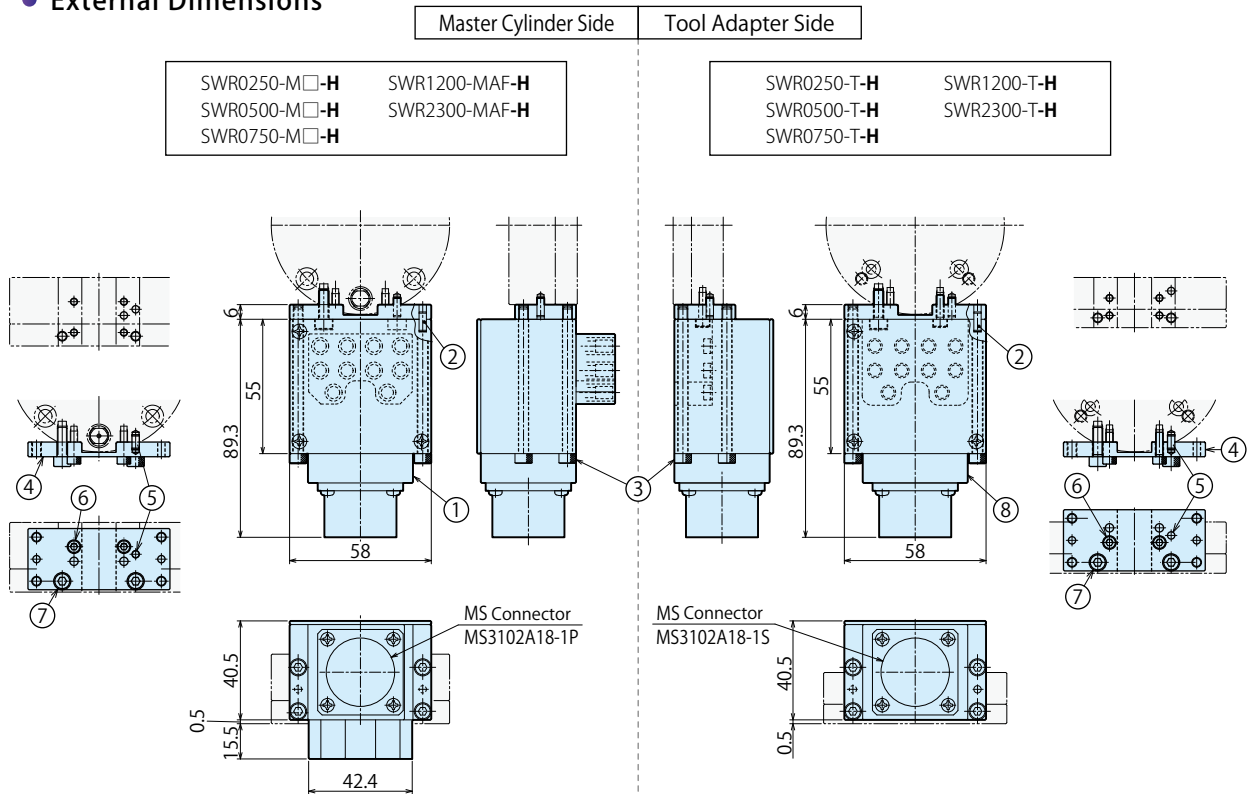

Model No.	No.	Name	Quantity
SWRZ0H0-M	①	Electrode (Master Side)	1
	②	Parallel Pin $\phi 3 \times 8$ B Type (SUS)	2
	③	Hexagon Socket Bolt M4×0.7×60 (SUS)	4
SWRZ0H0	④	Bracket (Common for Master/Tool Side)	1
	⑤	Parallel Pin $\phi 3 \times 6$ B Type (SUS)	1
	⑥	Hexagon Socket Bolt M3×0.5×10 (SUS)	2
	⑦	Hexagon Socket Bolt M4×0.7×12 (SUS)	2

Model No.	No.	Name	Quantity
SWRZ0H0-T	⑧	Electrode (Tool Side)	1
	②	Parallel Pin $\phi 3 \times 8$ B Type (SUS)	1
	③	Hexagon Socket Bolt M4×0.7×60 (SUS)	4
SWRZ0H0	④	Bracket (Common for Master/Tool Side)	1
	⑤	Parallel Pin $\phi 3 \times 6$ B Type (SUS)	1
	⑥	Hexagon Socket Bolt M3×0.5×10 (SUS)	2
	⑦	Hexagon Socket Bolt M4×0.7×12 (SUS)	2

Note : 1. Inform us with the model number shown above if you require an electrode only. (SWRZ0H0-□ : one set is one electrode.)

Locating + Clamp

Locating

Hand - Clamp

Support

Valve - Coupler

Cautions - Others

Robotic Hand Changer

SWR Payload 3kg ~ 360kg

SWR010 Payload 0.5kg ~ 1kg

Manual Robotic Hand Changer

SXR

Pneumatic Location Clamp

SWT

Compact Pneumatic Location Clamp

SWQ

High-Power Pneumatic Pallet Clamp

WVS

External Option : Servo Electrode

External Option Symbol : F01 / F02 / F05

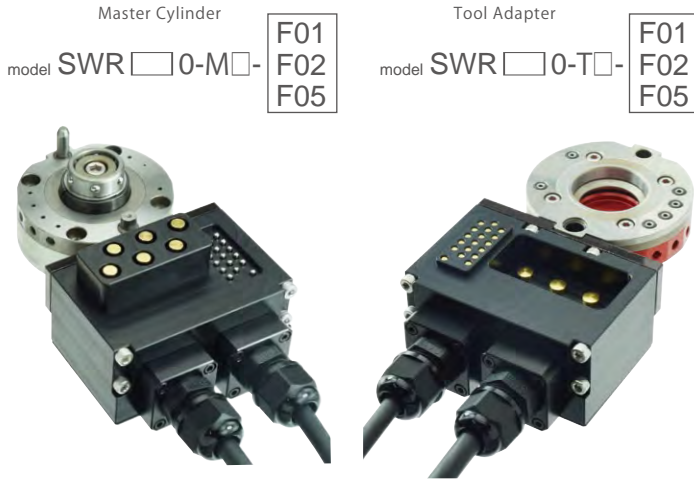

Specifications

Contact A for Power Supply		
Rated Value (per contact)	AC / DC 240V 20A ※1 ※2	
Number of Poles (per electrode)	6	
Contact B for Signal		
Rated Value (per contact)	DC 24V 3A	
Number of Poles (per electrode)	17 (for Signal) + 1 (for Functional Ground)	
Total Current Capacity	10A	
Cable Specifications		
Refer to the following table.		
Lead Wire Length	In case of - F01	1m
	In case of - F02	2m
	In case of - F05	5m
Weight※3	Master Cylinder Side	Electrode -F01 : 750g / -F02 : 1030g -F05 : 1850g Bracket : 32g
	Tool Adapter Side	Electrode -F01 : 710g / -F02 : 990g -F05 : 1810g Bracket : 32g

- ※1. Depending on the operating environment of a customer, the cable for power supply may become hot. Refer to the following conditions, and check if the maximum temperature in the operating environment combined with the temperature rise is safe before using the product.
 - After 5 minutes of use with all 6 poles at 50% usage rate of 20A (5 sec. ON/ 5 sec. OFF), the cable temperature rise is Δt= about 20°C.
 - After 5 minutes of use with all 6 poles at 100% usage rate of 20A and continuous current, the cable temperature rise is Δt=about 40°C.
- ※2. When supplying power for more than 5 minutes, reduce the current per electrode to suppress the temperature rise.
 - Example 1. Using multiple electrodes can reduce the current per pole.
 - Example 2. Suppress the surface temperature of cable coating installed in areas easily touched by people to below 60°C.
- ※3. Weight per electrode. Bracket weight shows the weight of SWR20F0.

Pin Numbers and Wire Colors

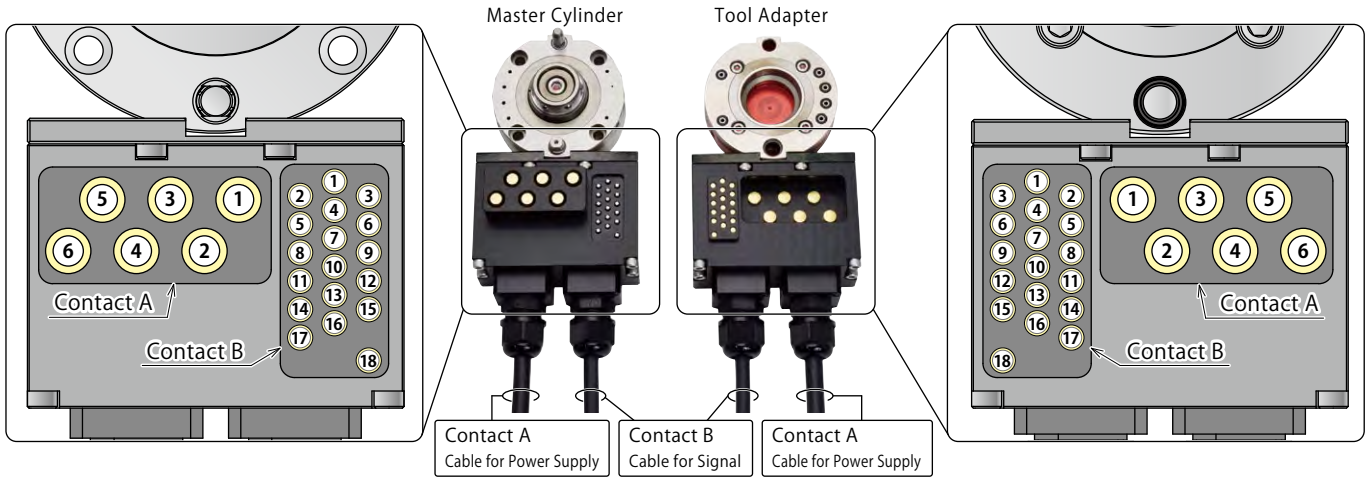

Contact A Cable for Power Supply	HIFLON SD/2586 6C×15AWG Black	Weight : 188g /m (Weight per meter)														
	NISSEI ELECTRIC Conductor Cross-Sectional Area : 2.0 mm ² (AWG15) Number of Cores : 6 Cable Rated Value Temp : 105°C Voltage : 600V															
		<table border="1"> <tr> <th>Pin Number</th> <td>1</td> <td>2</td> <td>3</td> <td>4</td> <td>5</td> <td>6</td> </tr> <tr> <th>Wire Color</th> <td>Brown</td> <td>Yellow</td> <td>Green</td> <td>Red</td> <td>White</td> <td>Black</td> </tr> </table>	Pin Number	1	2	3	4	5	6	Wire Color	Brown	Yellow	Green	Red	White	Black
Pin Number	1	2	3	4	5	6										
Wire Color	Brown	Yellow	Green	Red	White	Black										

Contact B Cable for Signal	HIFLON SD-SB/20276 10P×23AWG Black (with Shield)	Weight : 119g /m (Weight per meter)
	NISSEI ELECTRIC Conductor Cross-Sectional Area : 0.3mm ² (AWG23) Cable Rated Value Temp : 80°C Voltage : 30V	
		Number of Cores : 20

Pin Number	1	2	3	4	5	6	7	8	9	10	11	12	13	14	15	16	17	18(FG)	Not Used	Not Used
Wire Color	Yellow/Blue	Yellow/Red	Yellow/Black	White/Blue	White/Red	White/Black	Pink	Light Blue	Violet	Gray	Orange	Blue	Brown	Yellow	Green	Red	White	Black	Orange/Black	Orange/Blue
	Twisted Pair		Twisted Pair		Twisted Pair		Twisted Pair		Twisted Pair		Twisted Pair		Twisted Pair		Twisted Pair		Twisted Pair		Twisted Pair	

● External Dimensions

Master Cylinder Side	Tool Adapter Side
----------------------	-------------------

Electrode Part
 SWR0250-M□-F□ SWR0500-M□-F□ SWR0750-M□-F□
 SWR1200-MAF-F□ SWR2300-MAF-F□

Electrode Part
 SWR0250-T-F□ SWR0500-T-F□ SWR0750-T-F□
 SWR1200-T-F□ SWR2300-T-F□

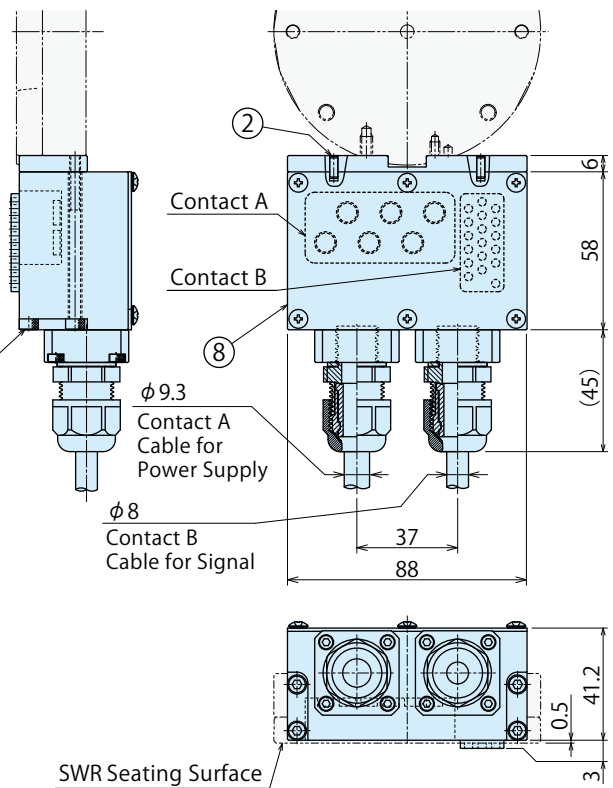
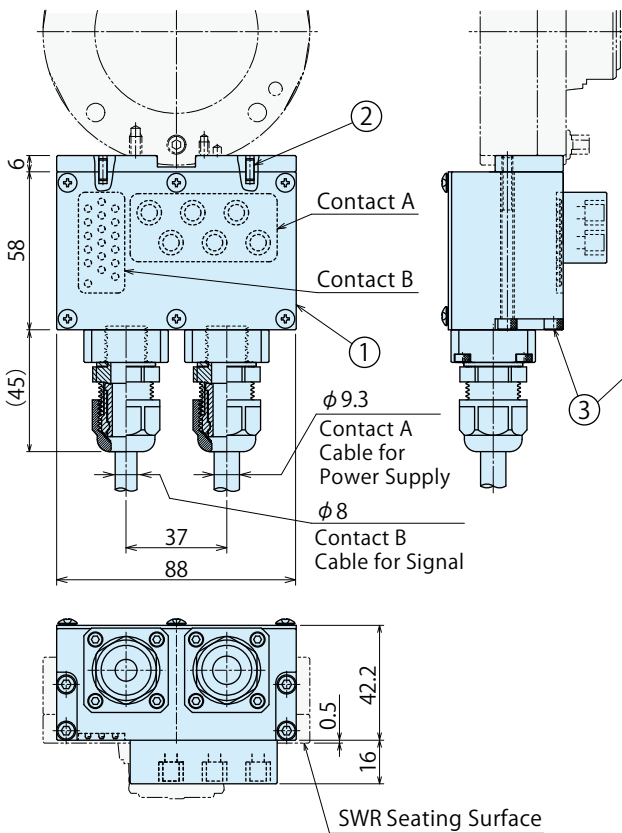

Bracket Part
 SWR0250-M□-F□ SWR0500-M□-F□ SWR0750-M□-F□
 SWR1200-MAF-F□ SWR2300-MAF-F□

Bracket Part
 SWR0250-T-F□ SWR0500-T-F□ SWR0750-T-F□
 SWR1200-T-F□ SWR2300-T-F□

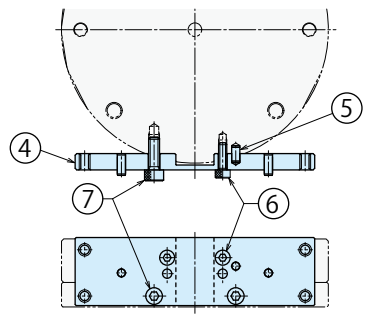
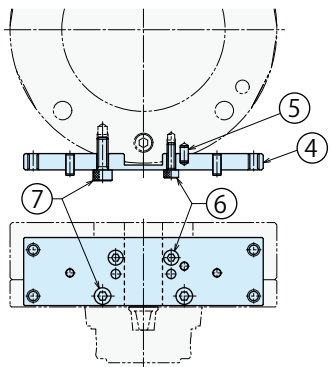

Model No.	No.	Name	Quantity
SWRZ0F0 -M01/M02/M05	①	Electrode (Master Side)	1
	②	Parallel Pin φ3×8 B type (SUS)	2
	③	Hex. Socket Bolt M4×0.7×60 (SUS)	4
	④	Bracket (Common for Master/Tool Side)	1
SWRZ0F0	⑤	Parallel Pin φ3×6 B type (SUS)	1
	⑥	Hex. Socket Bolt M3×0.5×10 (SUS)	2
	⑦	Hex. Socket Bolt M4×0.7×12 (SUS)	2

Model No.	No.	Name	Quantity
SWRZ0F0- -T01/T02/T05	⑧	Electrode (Tool Side)	1
	②	Parallel Pin φ3×8 B type (SUS)	2
	③	Hex. Socket Bolt M4×0.7×60(SUS)	4
	④	Bracket (Common for Master/Tool Side)	1
SWRZ0F0	⑤	Parallel Pin φ3×6 B type (SUS)	1
	⑥	Hex. Socket Bolt M3×0.5×10(SUS)	2
	⑦	Hex. Socket Bolt M4×0.7×12(SUS)	2

Notes : 1. Inform us with the model number shown above if you require an electrode only. (SWRZ0F0-□ : one set is one electrode.)
 2. For SWRZ0F0-□01/02/05 the lead wire length is different from its shown in the specifications.
 (SWRZ0F0-□01 : Lead Wire Length 1m, SWRZ0F0-□02 : Lead Wire Length 2m, SWRZ0F0-□05 : Lead Wire Length 5m)

- Locating + Clamp
- Locating
- Hand · Clamp
- Support
- Valve · Coupler
- Cautions · Others

- Robotic Hand Changer
 - SWR Payload 3kg ~ 360kg
 - SWR010 Payload 0.5kg ~ 1kg
- Manual Robotic Hand Changer
 - SXR
- Pneumatic Location Clamp
 - SWT
- Compact Pneumatic Location Clamp
 - SWQ
- High-Power Pneumatic Pallet Clamp
 - WVS

External Option : Compact Waterproof Electrode (Noncontact Waterproof Option) IP67

External Option Symbol : W/WX

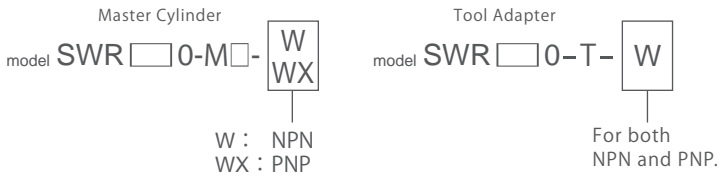

Specifications

Number of Signals (per electrode)	4	
Protection Grade ※1	IP67	
Cable	PUR ϕ 6.3 7×0.259mm ²	
Cable Length	Master Cylinder Side	2m
	Tool Adapter Side	1m
Weight ※2	Master Cylinder Side	Electrode 20g Cable 60g/m × 2m Bracket for SWR0030 8g
	Tool Adapter Side	Electrode 20g Cable 60g/m × 1m Bracket for SWR0030 8g

※1. Protection grade of the electrode part.

※2. Weight per electrode.

Bracket weight shows the weight of SWRZ050-T.

External Dimensions

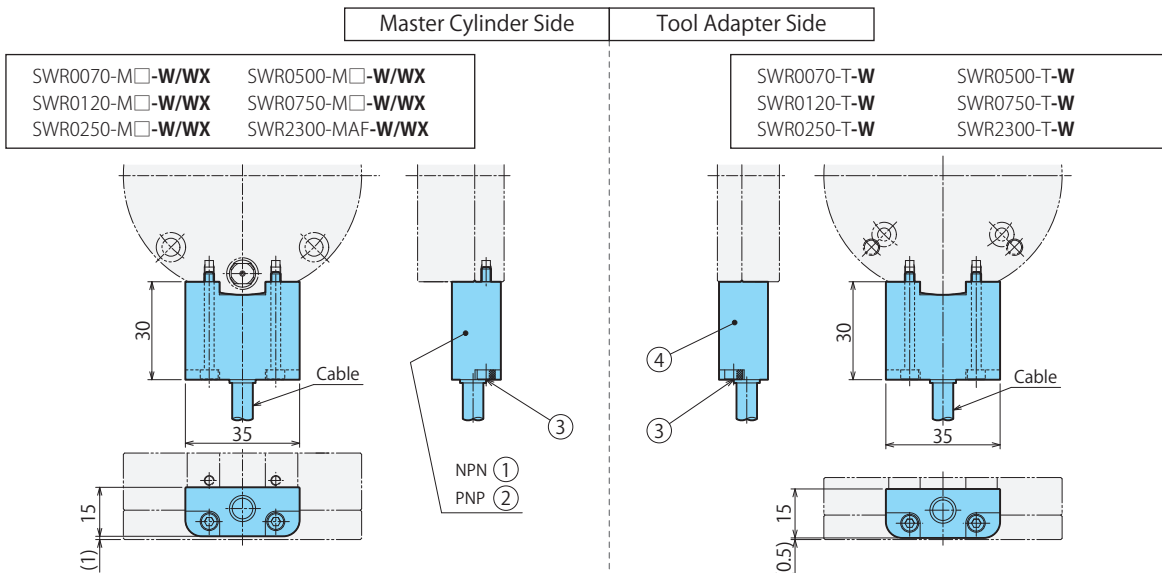

SWR0030-M-W/WX ※ Mount SWRZ050-T, only in case of SWR0030-M-W/WX.

SWR0030-T-W ※ Mount SWRZ050-T, only in case of SWR0030-T-W.

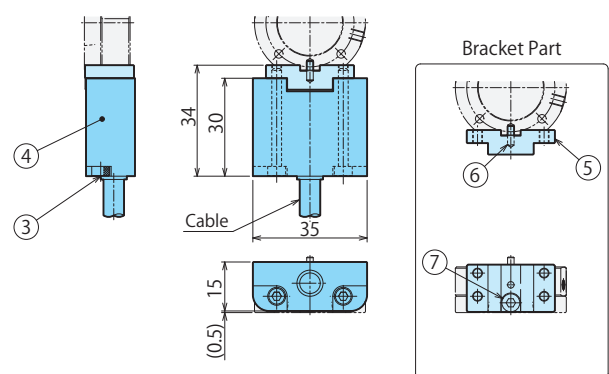
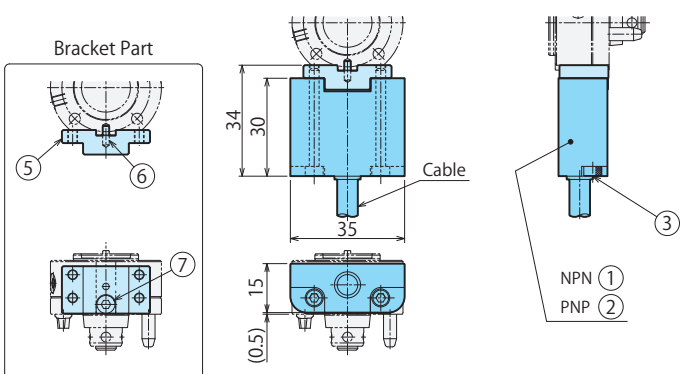

Model No.	No.	Name	Quantity
SWRZ0W0-M	①	Electrode (Master Side) NPN (B & Plus)	1
	③	Hexagon Socket Bolt M3×0.5×30 (SUS)	2
SWRZ0WX0-M	②	Electrode (Master Side) PNP (B & Plus)	1
	③	Hexagon Socket Bolt M3×0.5×30 (SUS)	2
SWRZ050-T	⑤	Bracket (Common for Master/Tool Side)	1
	⑥	Parallel Pin ϕ 2×6 B Type (SUS)	1
	⑦	Hexagon Socket Bolt M3×0.5×6 (SUS)	1

Model No.	No.	Name	Quantity
SWRZ0W0-T	④	Electrode (Tool Side)	1
	③	Hexagon Socket Bolt M3×0.5×30 (SUS)	2
SWRZ050-T	⑤	Bracket (Common for Master/Tool Side)	1
	⑥	Parallel Pin ϕ 2×6 B Type (SUS)	1
	⑦	Hexagon Socket Bolt M3×0.5×6 (SUS)	1

Notes : 1. Inform us with the model number shown above if you require an electrode only. (SWRZ0 W [] 0- [] : one set is one electrode.)
2. SWR1200 has a bracket. Please contact us for further information.

Details and Notes on External Option : Compact Noncontact Waterproof Electrode

Attention for Installation

(Read this section thoroughly before installation.)

- ◆ Ensure the power is switched off during installation or maintenance operations.
- ◆ Use a regulated power supply, e.g. switch-model type.
Simpler power supplies, such as a full-wave rectification type, will cause the permissible ripple rating to be exceeded and may cause malfunction.
- ◆ Ensure correct connections by referencing the wiring diagram.
- ◆ To avoid malfunction caused by induction noise, cable should be kept apart from motor or other power cable.

Electrode Specifications (Tool Adapter Side)

Model No.	SWR□□0-T□-W
Applicable Sensor	DC 3-Wire Sensor
Drive Voltage	12V ±1.5V DC
No. of Input Signals	4
Drive Current	≤ 30mA ≤ 60mA
Operating Distance	0~3mm 0~2mm
Center Offset	± 2mm ± 1mm
Operating Temperature	0 ~ +50°C
Protection Grade	IP67
Cable	PUR φ6.3 / 7x0.259mm ² Hitachi Metals, Ltd. RBT-VUCTF
Material	ABS
Weight	Body 20g + Cable 60g/m

Electrode Specifications (Master Cylinder Side)

Model No.	NPN	SWR□□0-M□-W
No.	PNP	SWR□□0-M□-WX
Supply Voltage	24V DC ± 10% (Including Ripple)	
Current Consumption	≤ 200mA	
No. of Output Signals	4 + 1 (Inzone)	
Load Current	≤ 50mA/1 Output	
LED Indication	Status (Green), Inzone (Orange)	
Circuit Protection	Short Circuit Protection, Converse Protection, Surge Suppression	
Operating Temperature	0 ~ +50°C	
Protection Grade	IP67	
Cable	PUR φ6.3 / 7x0.259mm ² Hitachi Metals, Ltd. RBT-VUCTF	
Material	ABS	
Weight	Body 20g + Cable 60g/m	

- Total current consumption of detectors must not exceed the rated drive current.
- Reduce the switches when the total current consumption exceeds the drive current.

Wiring Diagram

SWR□□0-M□-W : NPN

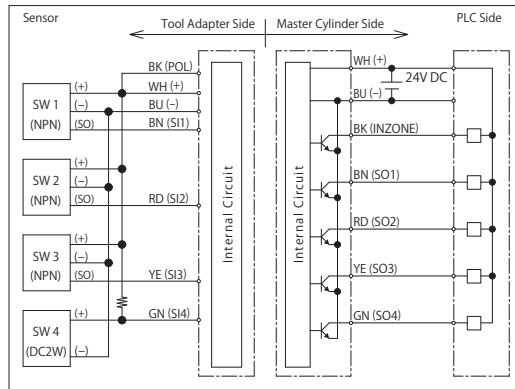

System Configuration

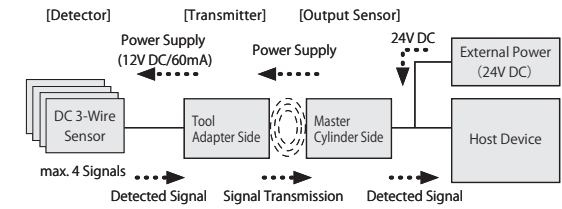

【Function of Each Component】

- Detector** : Connects Detector Sensor (max. 4) and transmits the detected signals to Transmitter.
- Transmitter** : Provides power for Detector, also passes detected signals from Detector to Output Sensor.
- Output Sensor** : Puts out detected signal to external controller, also sends power for operating of Detector and Transmitter.

Applicable Sensor

Supply Voltage	12V DC
Total Current Consumption	≤ 60mA
Residual Voltage	≤ 3.5V
Load Current	—

Bending Radius of Cable

The minimum bending radius for the sensors are 50mm.

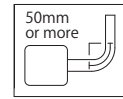

※ Do not pull the cable with excessive force when installing.

Installation Notes

In order to avoid influence of surrounding metal, or to avoid mutual influence between parallel-mounted sensors, keep the minimum free zone as described on the right.
(M3 Mounting Bolt
Tightening Torque : 0.63N · m)

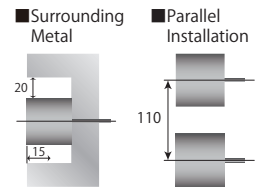

Locating + Clamp

Locating

Hand · Clamp

Support

Valve · Coupler

Cautions · Others

Robotic Hand Changer

SWR Payload
3kg ~ 360kg

SWR010
Payload
0.5kg ~ 1kg

Manual Robotic Hand Changer

SWR

Locating Location Clamp

SWT

Compact Pneumatic Location Clamp

SWQ

High-Power Pneumatic Pallet Clamp

WVS

■ SW4 of the wiring diagram is an example of the DC-2 wire sensor wiring (Recommend resistance is 1~2KΩ). DC-3 wire sensor can also be used.

LED Indication

■ Status LED (Green)

LED	Blinking	Pattern	Meaning
ON	—	—	The power is supplied.
OFF	—	—	The power is not supplied.
Blink	Slow (1.5 sec.)	OFF time of the LED is long.	Anomalous Temperature
Blink	Mid. Speed (0.6 sec.)	OFF time of the LED is long.	Supply voltage is high.
Blink	High Speed (0.2 sec.)	Lighting time of the LED is long.	Supply voltage is low.
Blink	High Speed (0.2 sec.)	The LED flashes at the same interval.	Short Circuit Protection

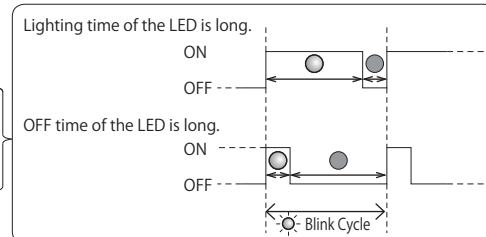

■ Status LED (Orange) The master cylinder and tool adapter are opposed, LED is lit when you can communicate.

The information above is quoted from B & Plus K.K. Remote System User's Guide (No.T315201D).

Please contact B & Plus K.K. (TEL 81(0)-493-71-5160) for further information about electrodes (Model No. SWRZ0W0-M-__ / SWRZ0W0-T-__).

External Option : Waterproof Electrode (Noncontact Waterproof Option) IP67

External Option Symbol : V/V5/VX/VX5

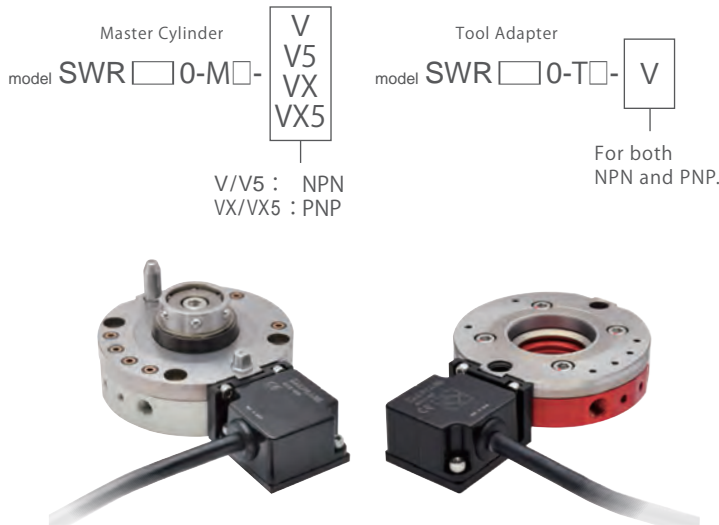

Specifications

Number of Signals (per electrode)	12 点	
Protection Grade ※1	IP67 対応	
Cable	PUR φ 8.6 2×0.5mm ² +13×0.18mm ²	
Cable Length	Master Cylinder Side -V	2m
	Tool Adapter Side	1m
	- VX	2m
	- V5 / VX5	5m
Weight※2	Master Cylinder Side -V / VX	Electrode + Bracket 130g Cable 210g
	Master Cylinder Side -V5 / VX5	Electrode + Bracket 130g Cable 525g
	Tool Adapter Side -V	Electrode + Bracket 130g Cable 105g

※1. Protection grade of the electrode part.

※2. Weight per electrode.

External Dimensions

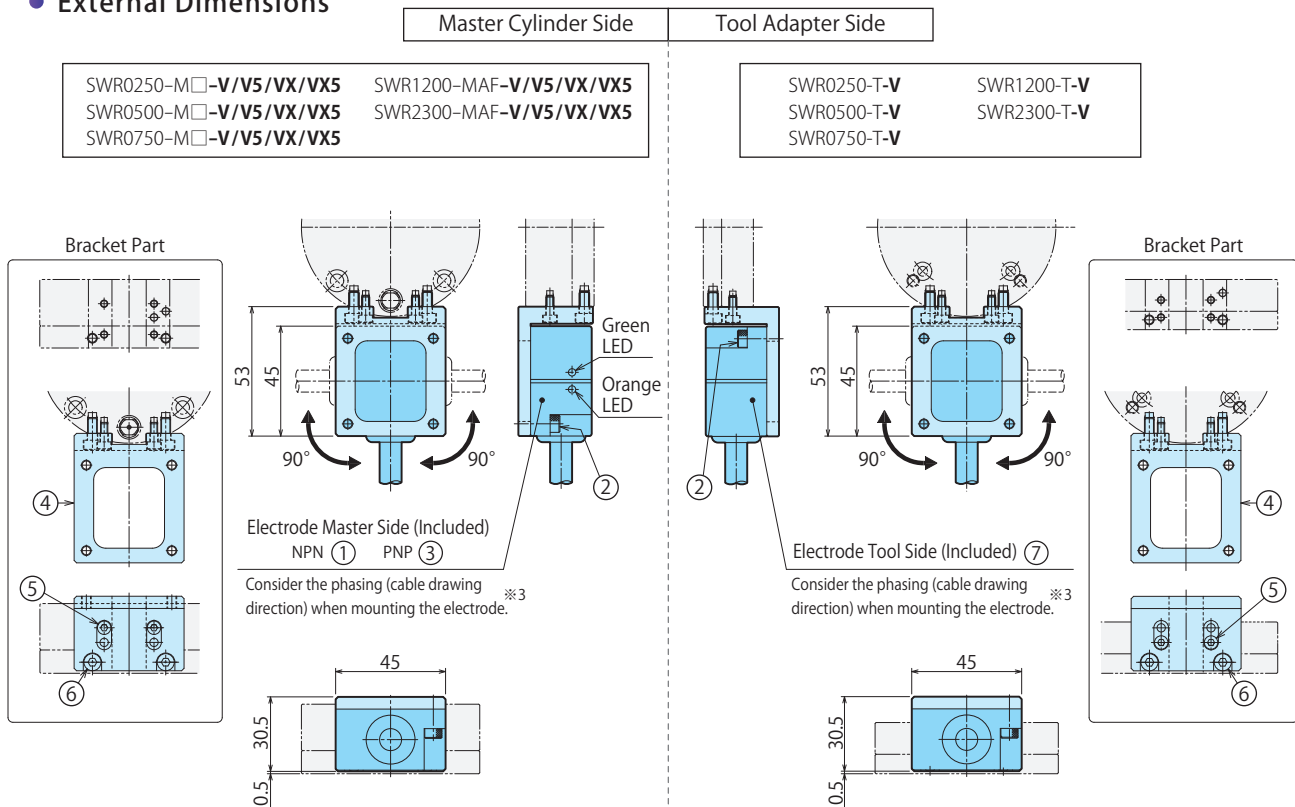

Model No.	No.	Name	Quantity
SWRZ0V0 -M/M05	①	Electrode (Master Side) NPN Made by B & Plus RS12E-422N-PU-02/05	1
	②	Hexagon Socket Bolt M4×0.7×12 (SUS)	2
SWRZ0VX0 -M/M05	③	Electrode (Master Side) PNP Made by B & Plus RS12E-422P-PU-02/05	1
	②	Hexagon Socket Bolt M4×0.7×12 (SUS)	2
SWRZ0V0	④	Bracket (Common for Master/Tool Side)	1
	⑤	Hexagon Socket Bolt M3×0.5×8 (SUS)	2
	⑥	Hexagon Socket Bolt M4×0.7×8 (SUS)	2

Model No.	No.	Name	Quantity
SWRZ0V0-T	⑦	Electrode (Tool Side) Made by B & Plus RS12T-422-PU-01	1
	⑧	Hexagon Socket Bolt M4×0.7×12 (SUS)	2
SWRZ0V0	④	Bracket (Common for Master/Tool Side)	1
	⑤	Hexagon Socket Bolt M3×0.5×8 (SUS)	2
	⑥	Hexagon Socket Bolt M4×0.7×8 (SUS)	2

Notes : 1. Inform us with the model number shown above if you require an electrode only. (SWRZ0 V□ 0-□ : one set is one electrode.)

2. For SWRZ0V0-M/M05 and SWRZ0VX0-M/M05, cable length of -M is 2m, and cable length of -M05 is 5m.

※3. Even if the mounting phase of electrode on master and tool sides is different, signals can be transmitted.

Determine the mounting phase of electrodes based on the cable drawing direction.

Details and Notes on External Option : Noncontact Waterproof Electrode

Attention for Installation

(Read this section thoroughly before installation.)

- ◆ Ensure the power is switched off during installation or maintenance operations.
- ◆ Use a regulated power supply, e.g. switch-model type. Simpler power supplies, such as a full-wave rectification type, will cause the permissible ripple rating to be exceed and may cause malfunction.
- ◆ Ensure correct connections by reference to the wiring diagram.
- ◆ To avoid malfunction caused by induction noise, cable should be kept apart from motor or other power cable.

Electrode Specifications (Tool Adapter Side)

Model No.	SWR□□0-T□-V
Applicable Sensor	DC 3-Wire Sensor
Drive Voltage	12V ±1.5V DC
Drive Current	≤ 230mA
No. of Input Signals	12
Operating Distance	2 ~ 5mm
Center Offset	± 3mm
Operating Temperature	0 ~ +50°C
Protection Class	IP67
Material	ABS

Electrode Specifications (Master Cylinder Side)

Model No.	NPN	SWR□□0-M□-V / V5
	PNP	SWR□□0-M□-VX / VX5
Supply Voltage	24V DC ± 10% (Including Ripple)	
Current Consumption	≤ 600mA	
No. of Output Signals	12 + 1 (Status)	
Load Current	≤ 50mA/1 Output	
LED Indication	Status (Green), Signal (Orange)	
Circuit Protection	Short Circuit Protection, High Temperature Protection, Converse Protection, Surge Suppression	
Operating Temperature	0 ~ +50°C	
Protection Class	IP67	
Material	ABS	

- Total current consumption of detectors must not exceed the rated drive current.
- Reduce the switches when the total current consumption exceeds the drive current.

Wiring Diagram

SWR□□0-M□-V / V5 : NPN

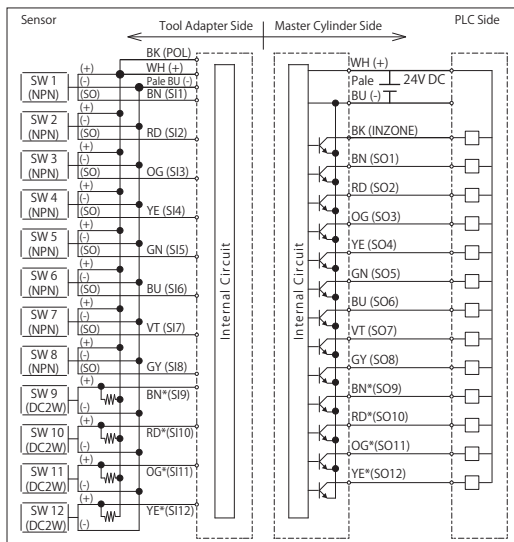

System Configuration

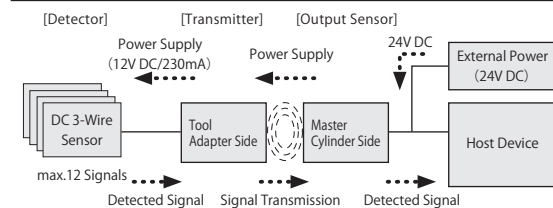

【Function of Each Component】

- Detector : Connects Detector Sensor (max. 12) and transmits the detected signals to Transmitter.
- Transmitter : Provides power for Detector, also passes detected signals from Detector to Output Sensor.
- Output Sensor : Puts out detected signal to external controller, also sends power for operating of Detector and Transmitter.

Applicable Sensor

Supply Voltage	12V DC
Total Current Consumption	≤ 230mA
Residual Voltage	≤ 3.5V
Load Current	—

Bending Radius of Cable

The minimum bending radius for the sensors are 50mm.

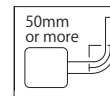

※ Do not pull the cable with excessive force when installing.

Installation Notes

In order to avoid influence of surrounding metal, or to avoid mutual influence between parallel-mounted sensors, keep the minimum free zone as described below.
(M4 Mounting Bolt)
Tightening Torque : 1.5N · m

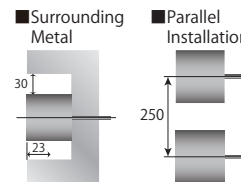

SWR□□0-M□-VX / VX5 : PNP

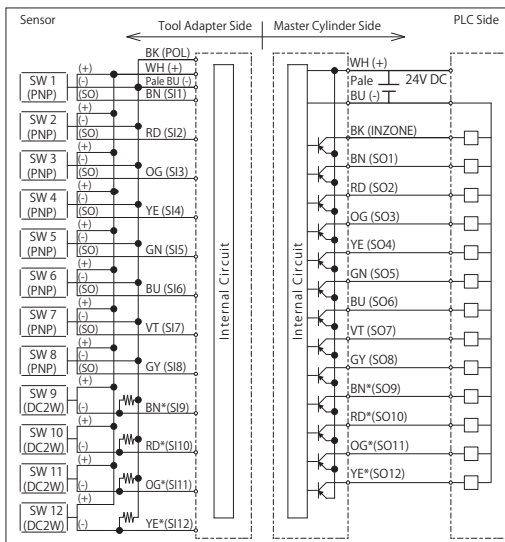

- SW9 ~ 12 of the wiring diagram is an example of the DC-2 wire sensor wiring (Recommend resistance is 1 ~ 2KΩ). DC-3 wire sensor can also be used.
- Cable GN* and BU* and VT* is not used.

LED Indication

■ Status LED (Green)

LED	Blinking	Pattern	Meaning
ON	—	—	The power is supplied.
OFF	—	—	The power is not supplied.
Blink (Slow)	Slow (1.5 sec.)	OFF time of the LED is long.	Abnormal Temperature
Blink (Mid-Speed)	Mid-Speed (0.6 sec.)	Lighting time of the LED is long.	Oscillation Circuit Overcurrent
Blink (High Speed)	High Speed (0.2 sec.)	OFF time of the LED is long.	Supply voltage is high.
Blink (High Speed)	High Speed (0.2 sec.)	Lighting time of the LED is long.	Supply voltage is low.
Blink (High Speed)	High Speed (0.2 sec.)	The LED flashes at the same interval.	Short Circuit Protection

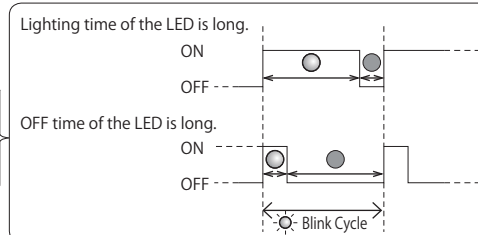

- Status LED (Orange) The master cylinder and tool adapter are opposed, LED is lit when you can communicate. When the output signal from each sensor and flash accordingly.

The information above is quoted from B & Plus K.K. Remote System User's Guide (No.T313A01E).
Please contact B & Plus K.K. (TEL 81(0)-493-71-5160) for further information about electrodes (Model No. RS12E-422□-PU-02/05 and RS12T-422-PU-01).

- Locating + Clamp
- Locating
- Hand · Clamp
- Support
- Valve · Coupler
- Cautions · Others

Robotic Hand Changer

SWR Payload	3kg ~ 360kg
SWR010 Payload	0.5kg ~ 1kg

Manual Robotic Hand Changer
SXR

Placement Location Clamp
SWT

Compact Pneumatic Location Clamp
SWQ

High-Power Pneumatic Pallet Clamp
WVS

External Option : Ground Electrode

External Option Symbol : T

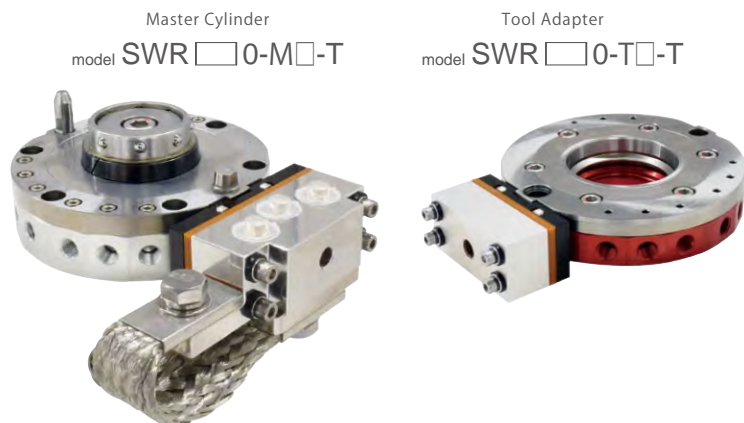

Specifications

Rated Capacity		500A (Activity Ratio 50%)
Weight ※1	Master Cylinder Side	Electrode 1200g Bracket 55g
	Tool Adapter Side	Electrode 400g Bracket 35g

※1. Weight per electrode. Bracket weight shows the weight of SWRZ0T0-MB, SWRZ0T0-TB.

Ground Electrode Application Example

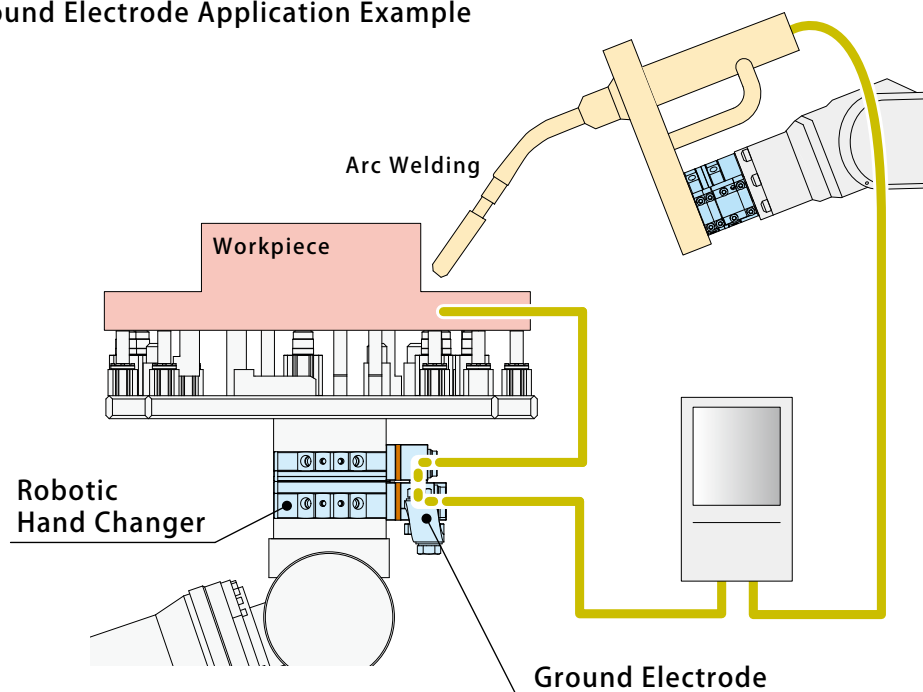

Activity Ratio

Activity ratio shows the ratio of load time when welding with rated capacity to the prescribed period (10 minutes in JIS standard). Make sure that the activity ratio does not exceed 50% which is the rated activity ratio of the ground electrode (SWRZ0T0).

$$\text{Activity Ratio (\%)} = \frac{\text{Welding Time (min.)}}{\text{Prescribed Period (10 min.)}} \times 100$$

$$\text{Allowable Activity Ratio (\%)} = \frac{(\text{Rated Capacity } 500 \text{ (A)})^2}{(\text{Operating Current (A)})^2} \times \text{Rated Activity Ratio } 50 \text{ (\%)}$$

In case of Ground Electrode (SWRZ0T0) :

- Ex.1) When welding with 500A, because the activity ratio is 50%, it can be operated for 5 minutes and needs to be suspended for 5 minutes in a 10-minute period.
- Ex.2) When welding with 390A, the activity ratio is 78% so it can be operated for about 8 minutes and needs to be suspended for about 2 minutes in a 10-minute period.
- Ex.3) Unable to be operated when exceeding the rated capacity 500A. Please contact us.

Notes for Usage

The stroke of the ground electrode (SWRZ0T0) is larger than the lifting stroke (detaching stroke) of SWR. When not pressing with a robot, SWR tilts during connecting operation so that connection may not be completed. Press not to tilt until SWR reaches the released (lifted) position by using a robot, etc.

● External Dimensions

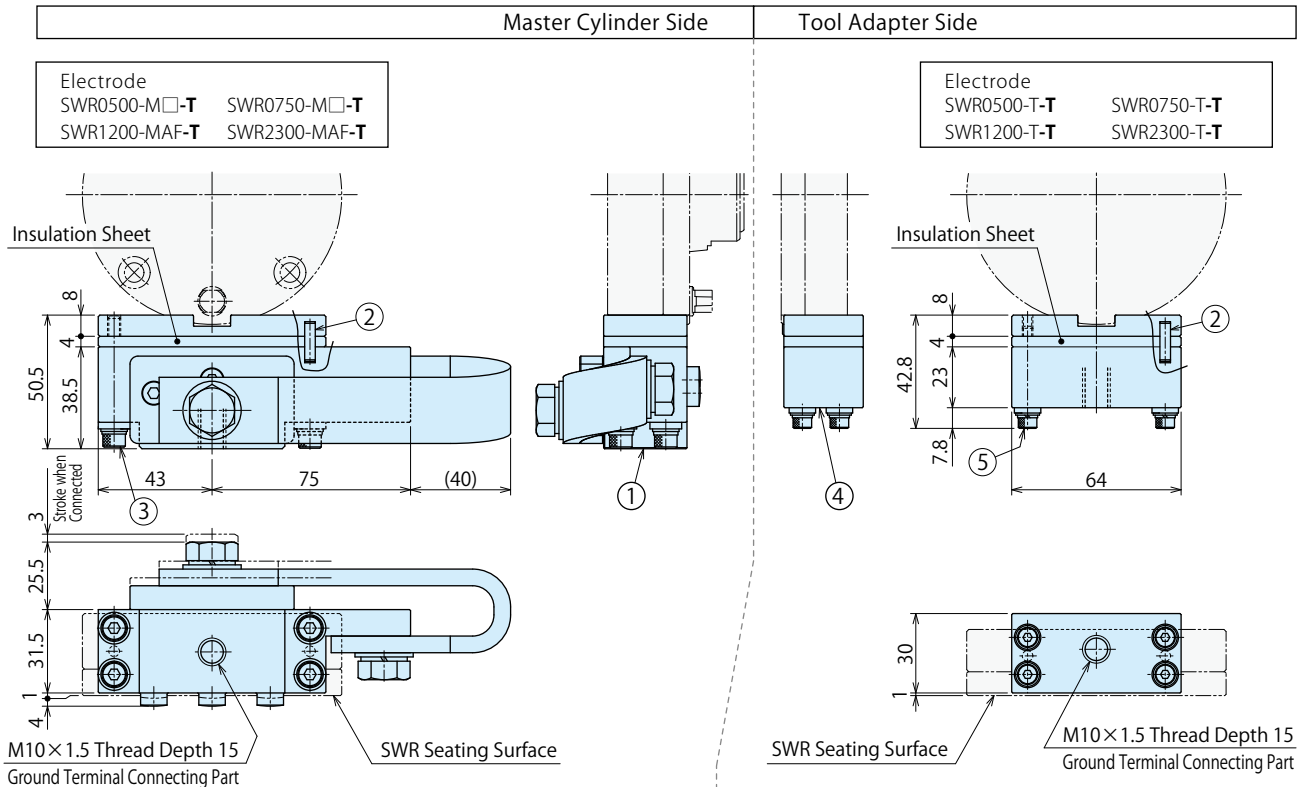

- Locating + Clamp
- Locating
- Hand + Clamp
- Support
- Valve + Coupler
- Cautions + Others

- Robotic Hand Changer
 - SWR Payload 3kg ~ 360kg
 - SWR010 Payload 0.5kg ~ 1kg
- Manual Robotic Hand Changer
 - SXR
- Pneumatic Location Clamp
 - SWT
- Compact Pneumatic Location Clamp
 - SWQ
- High-Power Pneumatic Pallet Clamp
 - WVS

Bracket
SWR0500-M□-T SWR0750-M□-T

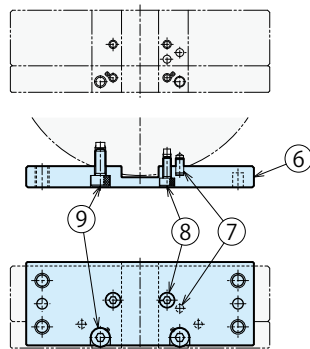

Bracket
SWR0500-T-T SWR0750-T-T

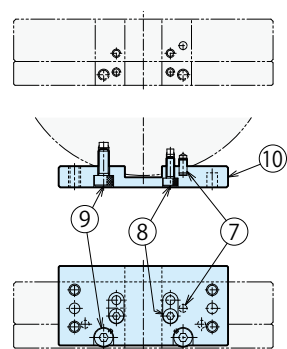

Bracket
SWR1200-MAF-T SWR2300-MAF-T

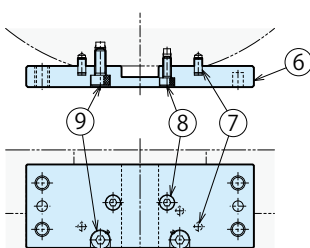

Bracket
SWR1200-T-T SWR2300-T-T

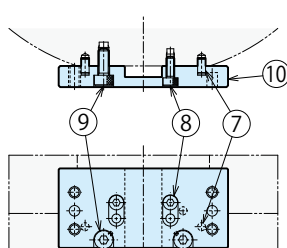

Model No.	No.	Name	Quantity
SWRZ0T0-M	①	Electrode (Master Side) ※Including Insulation Sheet	1
	②	Parallel Pin φ4×15 (Resin)	2
	③	Hexagonal Socket Bolt M5×0.8×45 (SUS)	4
SWRZ0T0-MB	⑥	Bracket (Master Side)	1
	⑦	Parallel Pin φ3×6 B Type (SUS)	2 (1※2)
	⑧	Hexagonal Socket Bolt M3×0.5×8 (SUS)	2
	⑨	Hexagonal Socket Bolt M4×0.7×10 (SUS)	2

Model No.	No.	Name	Quantity
SWRZ0T0-T	④	Electrode (Tool Side) ※Including Insulation Sheet	1
	②	Parallel Pin φ4×15 (Resin)	2
	⑤	Hexagon Socket Bolt M4×0.7×35 (SUS)	4
SWRZ0T0-TB	⑩	Bracket (Tool Side)	1
	⑦	Parallel Pin φ3×6 B Type (SUS)	2 (1※2)
	⑧	Hexagonal Socket Bolt M3×0.5×8 (SUS)	2
	⑨	Hexagonal Socket Bolt M4×0.7×10 (SUS)	2

Notes : 1. Inform us with the model number shown above if you require an electrode only. (SWRZ0T0-□ : one set is one electrode.)
 ※2. In case of SWR0500/0750, only one parallel pin (②) is used.

External Option : Ethernet Electrode

External Option Symbol : L

Master Cylinder
model SWR □ 0-M □ -L

Tool Adapter
model SWR □ 0-T-L



Specifications

Rated Value (per contact)	DC 30V 0.5A	
Number of Poles (per electrode)	4	
Connector	M12 D-code 4 poles (female) (based on IEC61076-2-101)	
Ethernet Applicable Standard	100BASE-TX	
Transmission Speed	100Mbps	
Category	CAT5	
Applicable Fieldbus	EtherNet/IP EtherCAT PROFINET Modbus TCP CC-Link IE Field Network Basic ※2	
Weight※1	Master Cylinder Side	Electrode : 106g Bracket : 16g
	Tool Adapter Side	Electrode : 96g Bracket : 16g

※1. Weight per electrode. Bracket weight shows the weight of SWRZ0E0.

※2. Cannot be used with a fieldbus that requires a communication speed of 1Gbps such as CC-Link IE.

External Dimensions (SWR0250/SWR0500/SWR0750)

Master Cylinder Side			Tool Adapter Side		
SWR0250-M □ -L	SWR0500-M □ -L	SWR0750-M □ -L	SWR0250-T-L	SWR0500-T-L	SWR0750-T-L

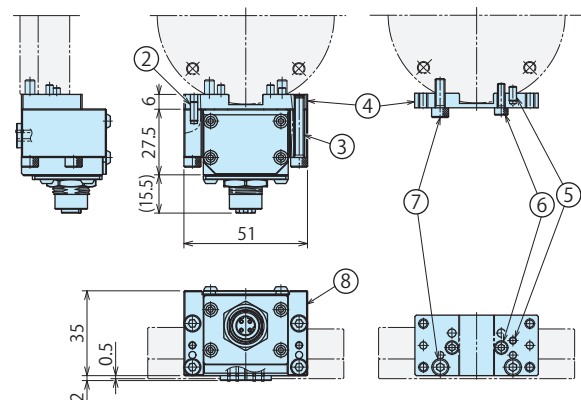
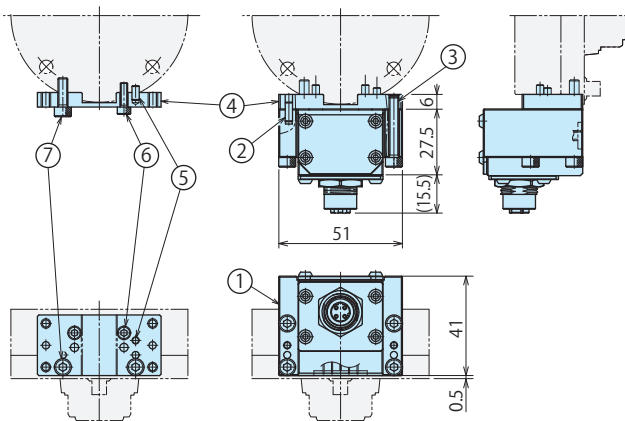

Model No.	No.	Name	Quantity
SWRZ0L0-M	①	Electrode (Master Side)	1
	②	Parallel Pin $\phi 3 \times 8$ B Type (SUS)	2
	③	Hexagon Socket Bolt M4×0.7×25 (SUS)	4
SWRZ0E0	④	Bracket (Common for Master/Tool Side)	1
	⑤	Parallel Pin $\phi 3 \times 6$ B Type (SUS)	1
	⑥	Hexagon Socket Bolt M3×0.5×10 (SUS)	2
	⑦	Hexagon Socket Bolt M4×0.7×12 (SUS)	2

Model No.	No.	Name	Quantity
SWRZ0L0-T	⑧	Electrode (Tool Side)	1
	②	Parallel Pin $\phi 3 \times 8$ B Type (SUS)	2
	③	Hexagon Socket Bolt M4×0.7×25 (SUS)	4
SWRZ0E0	④	Bracket (Common for Master/Tool Side)	1
	⑤	Parallel Pin $\phi 3 \times 6$ B type (SUS)	1
	⑥	Hexagon Socket Bolt M3×0.5×10 (SUS)	2
	⑦	Hexagon Socket Bolt M4×0.7×12 (SUS)	2

Notes: 1. Inform us with the model number shown above if you require an electrode only. (SWRZ0L0-□ : one set is one electrode.)

● External Dimensions(SWR1200/SWR2300)

Master Cylinder Side		Tool Adapter Side																													
SWR1200-M□-L	SWR2300-MAF-L	SWR1200-T-L	SWR2300-T-L																												
<table border="1" style="width:100%; border-collapse: collapse;"> <thead> <tr> <th>Model No.</th> <th>No.</th> <th>Name</th> <th>Quantity</th> </tr> </thead> <tbody> <tr> <td rowspan="3" style="text-align: center;">SWRZ0L0-M</td> <td style="text-align: center;">①</td> <td>Electrode (Master Side)</td> <td style="text-align: center;">1</td> </tr> <tr> <td style="text-align: center;">②</td> <td>Parallel Pin $\phi 3 \times 8$ B Type (SUS)</td> <td style="text-align: center;">2</td> </tr> <tr> <td style="text-align: center;">③</td> <td>Hexagon Socket Bolt M4×0.7×25 (SUS)</td> <td style="text-align: center;">4</td> </tr> </tbody> </table>	Model No.	No.	Name	Quantity	SWRZ0L0-M	①	Electrode (Master Side)	1	②	Parallel Pin $\phi 3 \times 8$ B Type (SUS)	2	③	Hexagon Socket Bolt M4×0.7×25 (SUS)	4		<table border="1" style="width:100%; border-collapse: collapse;"> <thead> <tr> <th>Model No.</th> <th>No.</th> <th>Name</th> <th>Quantity</th> </tr> </thead> <tbody> <tr> <td rowspan="3" style="text-align: center;">SWRZ0L0-T</td> <td style="text-align: center;">⑧</td> <td>Electrode (Tool Side)</td> <td style="text-align: center;">1</td> </tr> <tr> <td style="text-align: center;">②</td> <td>Parallel Pin $\phi 3 \times 8$ B Type (SUS)</td> <td style="text-align: center;">2</td> </tr> <tr> <td style="text-align: center;">③</td> <td>Hexagon Socket Bolt M4×0.7×25 (SUS)</td> <td style="text-align: center;">4</td> </tr> </tbody> </table>	Model No.	No.	Name	Quantity	SWRZ0L0-T	⑧	Electrode (Tool Side)	1	②	Parallel Pin $\phi 3 \times 8$ B Type (SUS)	2	③	Hexagon Socket Bolt M4×0.7×25 (SUS)	4	
Model No.	No.	Name	Quantity																												
SWRZ0L0-M	①	Electrode (Master Side)	1																												
	②	Parallel Pin $\phi 3 \times 8$ B Type (SUS)	2																												
	③	Hexagon Socket Bolt M4×0.7×25 (SUS)	4																												
Model No.	No.	Name	Quantity																												
SWRZ0L0-T	⑧	Electrode (Tool Side)	1																												
	②	Parallel Pin $\phi 3 \times 8$ B Type (SUS)	2																												
	③	Hexagon Socket Bolt M4×0.7×25 (SUS)	4																												

Notes: 1. For SWR1200/SWR2300, SWRZ0E0 is not required.

- Locating + Clamp
- Locating
- Hand + Clamp
- Support
- Valve + Coupler
- Cautions + Others

- Robotic Hand Changer
 - SWR Payload 3kg ~ 360kg
 - SWR0010 Payload 0.5kg ~ 1kg
- Manual Robotic Hand Changer
 - SXR
- Pneumatic Location Clamp
 - SWT
- Compact Pneumatic Location Clamp
 - SWQ
- High-Power Pneumatic Pallet Clamp
 - WVS

External Option : Air Joint (3-Port Option (1 Port Rc1/8))

Extensible Options :
Resin Connector, Solder Terminal

External Option Symbol : R

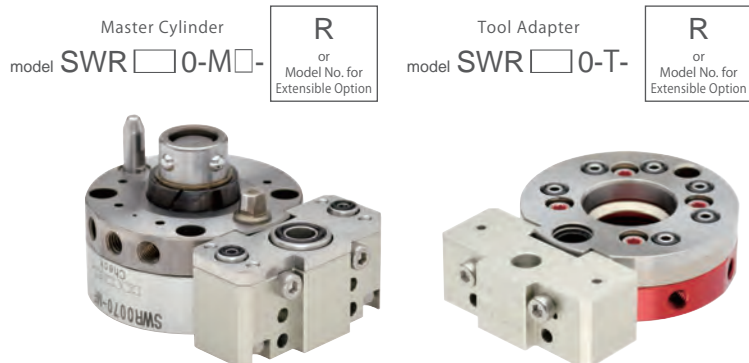

Specifications

Port Size	Rc1/8	M5	
Number of Ports	1	2	
Operating Pressure	SWR0070 or larger	max. 0.7MPa (Vacuum Available)	
	SWR0030	max. 0.5MPa (Vacuum Available)	
Withstanding Pressure	1.1MPa		
Min. Passage Area	28.3mm ²	3.1mm ²	
Operating Temperature	0 ~ 70°C		
Usable Fluid	Dry Air		
Reaction Force (per port)	Pressure at 0.7 MPa	0.13 kN	0.04kN
	Pressure at 0.5 MPa	0.10 kN	0.03kN
	Pressure at P MPa	0.154×P+0.019 kN	0.047×P+0.008 kN
Weight ※1	Master Cylinder Side	Air Joint 51g Bracket for SWR0030-M : 10g	
	Tool Adapter Side	Air Joint 25g Bracket for SWR0030-T : 8g	

※1. Weight per joint.

Bracket weight is the weight of SWRZ050-□.

Extensible Options Additional electrode can be extended to the option : R.

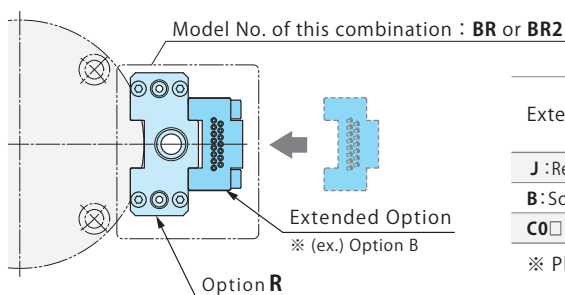

Extensible Electrode	Model No. for Extensible Option					
	SWR 0030	SWR 0070	SWR 0120	SWR 0250	SWR 0500	SWR 0750
J : Resin Connector		JR	JR	JR2	JR2	JR2
B : Solder Terminal	N/A	BR	BR	BR2	BR2	BR2
CO□ : Cable with Solder Terminal		CO□R	CO□R	CO□R2	CO□R2	CO□R2

※ Please contact us for detailed dimensions for extensible options.

External Dimensions (SWR0070/SWR0120/SWR0250/SWR0500/SWR0750)

Master Cylinder Side			Tool Adapter Side				
SWR0070-M□-R SWR0250-M□-R SWR0750-M□-R SWR0120-M□-R SWR0500-M□-R			SWR0070-T-R SWR0250-T-R SWR0750-T-R SWR0120-T-R SWR0500-T-R				
Model No.	No.	Name	Quantity	Model No.	No.	Name	Quantity
SWRZ0R0-M	①	Joint (Master Side)	1	SWRZ0R0-T	④	Joint (Tool Side)	1
	②	Parallel Pin φ 1.5×4 B Type (SUS)	2		②	Parallel Pin φ 1.5×4 B Type (SUS)	2
	- ※2	③	Hexagon Socket Bolt M3×0.5×20 (SUS)		2	- ※2	③

Note : 1. Inform us with the model number shown above if you require an air joint only. (SWRZ0R0-□ : one set is one air joint.)
For SWRZ0R0-M / SWRZ0R0-T, the bolt marked with ※2 is not included.

● External Dimensions (SWR0030)

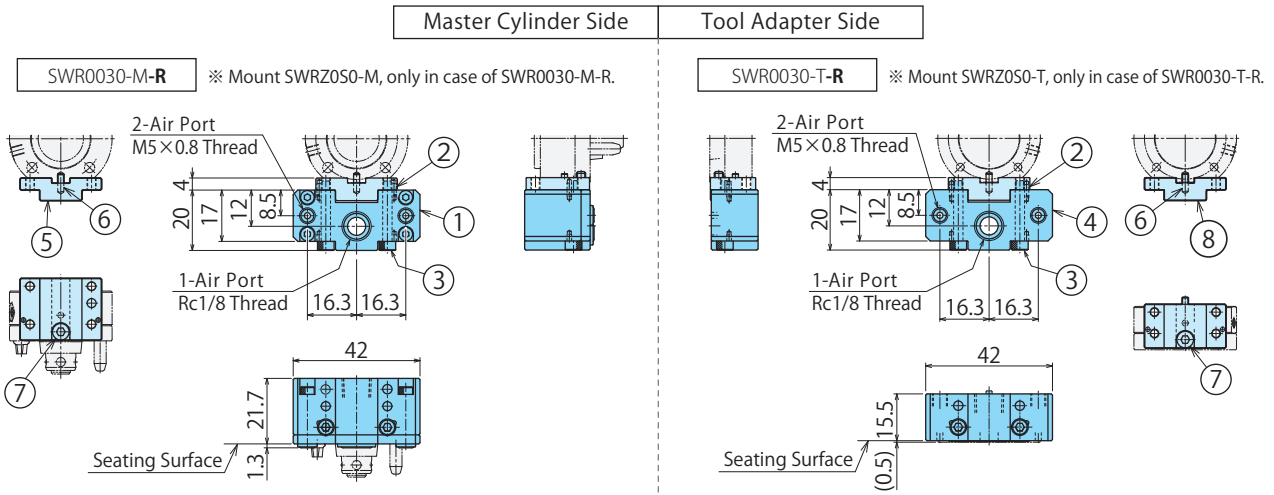

Model No.	No.	Name	Quantity
SWRZ0R0-M	①	Joint (Master Side)	1
	②	Parallel Pin $\phi 1.5 \times 4$ B Type (SUS)	2
	③	Hexagon Socket Bolt M3 $\times 0.5 \times 20$ (SUS)	2
- ※2			
SWRZ0S0-M	⑤	Bracket (Master Side)	1
	⑥	Parallel Pin $\phi 2 \times 6$ B Type (SUS)	1
	⑦	Hexagon Socket Bolt M3 $\times 0.5 \times 6$ (SUS)	1

Model No.	No.	Name	Quantity
SWRZ0R0-T	④	Joint (Tool Side)	1
	②	Parallel Pin $\phi 1.5 \times 4$ B Type (SUS)	2
	③	Hexagon Socket Bolt M3 $\times 0.5 \times 20$ (SUS)	2
- ※2			
SWRZ0S0-T	⑧	Bracket (Tool Side)	1
	⑥	Parallel Pin $\phi 2 \times 6$ B Type (SUS)	1
	⑦	Hexagon Socket Bolt M3 $\times 0.5 \times 6$ (SUS)	1

Note: 1. Inform us with the model number shown above if you require an air joint only. (SWRZ0R0-□ : one set is one air joint.)
For SWRZ0R0-M / SWRZ0R0-T / SWRZ0S0-M / SWRZ0S0-T, the bolt marked with ※2 is not included.

- Locating + Clamp
- Locating
- Hand + Clamp
- Support
- Valve + Coupler
- Cautions + Others
- Robotic Hand Changer
 - SWR Payload 3kg ~ 360kg
 - SWR010 Payload 0.5kg ~ 1kg
- Manual Robotic Hand Changer
 - SXR
- Pneumatic Location Clamp
 - SWT
- Compact Pneumatic Location Clamp
 - SWQ
- High-Power Pneumatic Pallet Clamp
 - WVS

External Option : Air Joint (4-Port, Solder Terminal Extensible Option)

Extensible Options : Resin Connector, Solder Terminal

External Option Symbol : P

Master Cylinder
model SWR □ 0-M □ -
P
or
Model No. for
Extensible Option

Tool Adapter
model SWR □ 0-T -
P
or
Model No. for
Extensible Option



Specifications

Number of Ports	4	
Operating Pressure	max. 1.0MPa (Vacuum Available)	
Withstanding Pressure	1.5MPa	
Min. Passage Area	2.0mm ² (Equal to φ 1.6)	
Operating Temperature	0 ~ 70°C	
Usable Fluid	Dry Air	
Reaction Force (per port)	Pressure at 1 MPa	0.03 kN
	Pressure at 0.5MPa	0.02 kN
	Pressure at P MPa	0.027 × P + 0.004 kN
Weight ※1	Master Cylinder Side	Joint 43g
	Tool Adapter Side	Joint 26g

※1. Weight per joint.

Extensible Options Additional electrode can be extended to the option : P .

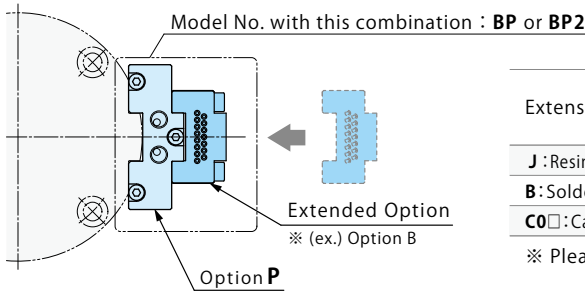

Extensible Electrode	Model No. for Extensible Option				
	SWR 0070	SWR 0120	SWR 0250	SWR 0500	SWR 0750
J : Resin Connector	JP	JP	JP2	JP2	JP2
B : Solder Terminal	BP	BP	BP2	BP2	BP2
C□ : Cable with Solder Terminal	C□P	C□P	C□P2	C□P2	C□P2

※ Please contact us for detailed dimensions for extensible options.

External Dimensions

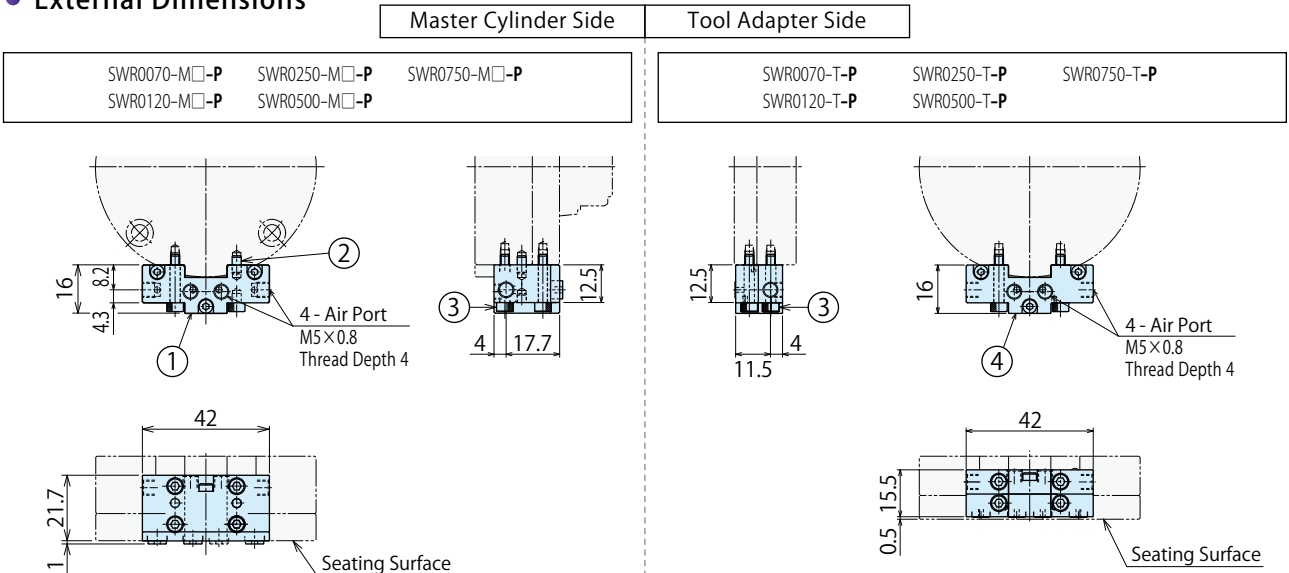

Model No.	No.	Name	Quantity
SWRZ0P0-M	①	Joint (Master Side)	1
	②	Parallel Pin φ3×6 B Type (SUS)	1
	※2	Hexagon Socket Bolt M3×0.5×16 (SUS)	4

Model No.	No.	Name	Quantity
SWRZ0P0-T	④	Joint (Tool Side)	1
	③	Hexagon Socket Bolt M3×0.5×16 (SUS)	4

Notes : 1. Inform us with the model number shown above if you require an air joint only. (SWRZ0P0-□ : one set is one air joint.)
For SWRZ0P0-M / SWRZ0P0-T, the bolt marked with ※2 is not included.
2. Please contact us for SWR1200.

● External Option : Air Joint

External Option Symbol : Q

Master Cylinder
model SWR□□0-M□-Q



Tool Adapter
model SWR□□0-T□-Q

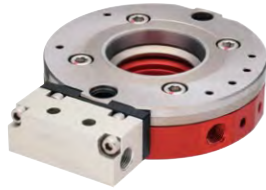

● Specifications

Number of Ports	2	
Operating Pressure	max. 1.0MPa (Vacuum Available)	
Withstanding Pressure	1.5MPa	
Min. Passage Area	12.6mm ² (Equal to φ4)	
Operating Temperature	0 ~ 70°C	
Usable Fluid	Dry Air	
Reaction Force (per port)	Pressure at 1 MPa	0.13 kN
	Pressure at 0.5MPa	0.07 kN
	Pressure at P MPa	0.117×P +0.01 kN
Weight ※1	Master Cylinder Side	Joint 70g / Bracket 17g
	Tool Adapter Side	Joint 60g / Bracket 17g

※1. Weight per joint.

Bracket weight is the weight of SWRZ0Z0.

● External Dimensions

Master Cylinder Side

Tool Adapter Side

SWR0250-M□-Q
SWR0500-M□-Q
SWR0750-M□-Q

SWR0250-T-Q
SWR0500-T-Q
SWR0750-T-Q

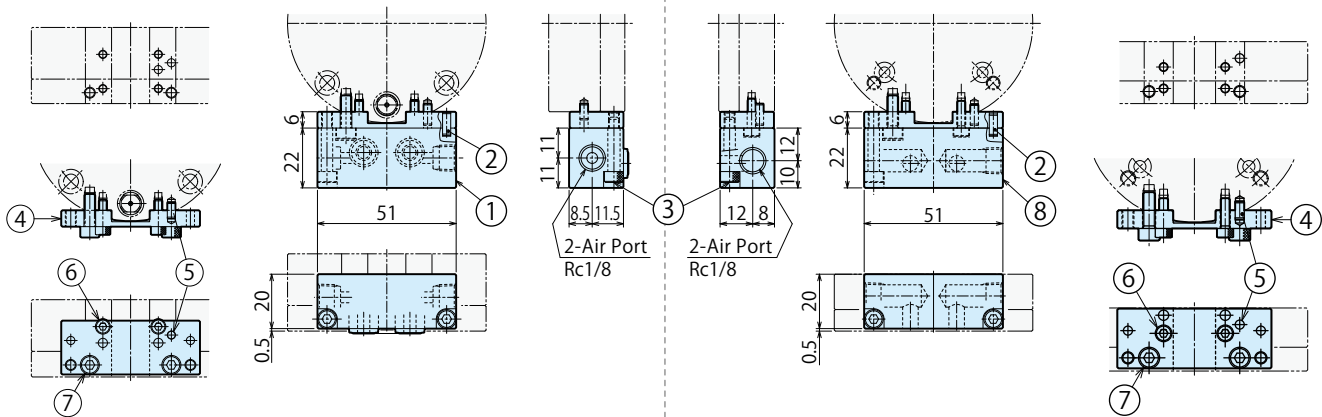

Model No.	No.	Name	Quantity
SWRZ0Q0-M	①	Joint (Master Side)	1
	②	Parallel Pin φ3×8 B Type (SUS)	2
	③	Hexagon Socket Bolt M4×0.7×20 (SUS)	2
SWRZ0Z0	④	Bracket (Common for Master/Tool Side)	1
	⑤	Parallel Pin φ3×8 B Type (SUS)	1
	⑥	Hexagon Socket Bolt M3×0.5×10 (SUS)	2
	⑦	Hexagon Socket Bolt M4×0.7×12 (SUS)	2

Model No.	No.	Name	Quantity
SWRZ0Q0-T	⑧	Joint (Tool Side)	1
	②	Parallel Pin φ3×8 B Type (SUS)	2
	③	Hexagon Socket Bolt M4×0.7×20 (SUS)	2
SWRZ0Z0	④	Bracket (Common for Master/Tool Side)	1
	⑤	Parallel Pin φ3×8 B Type (SUS)	1
	⑥	Hexagon Socket Bolt M3×0.5×10 (SUS)	2
	⑦	Hexagon Socket Bolt M4×0.7×12 (SUS)	2

- Notes : 1. Inform us with the model number shown above if you require an air joint only. (SWRZ0Q0-□ : one set is one air joint.)
2. Please contact us for SWR1200.

Locating + Clamp

Locating

Hand · Clamp

Support

Valve · Coupler

Cautions · Others

Robotic Hand Changer

SWR Payload 3kg ~ 360kg

SWR010 Payload 0.5kg ~ 1kg

Manual Robotic Hand Changer

SXR

Pneumatic Location Clamp

SWT

Compact Pneumatic Location Clamp

SWQ

High-Power Pneumatic Pallet Clamp

WVS

● Port Option

Master Cylinder Model No.

SWR 003 0 - M Blank - - ※ SWR0030 has no air blow port or seat check port.

SWR 007
012
025
050
075 0 - M A
F - -

SWR 120
230 0 - M AF - -

Payload

3 Port Option Symbol

● Port Option Symbol **A** : With Air Blow Port

When connecting, there is moderate clearance between the taper reference surface and seating surface that enables high accuracy. This allows for effective cleaning with air blow, contamination prevention and longer operational life.

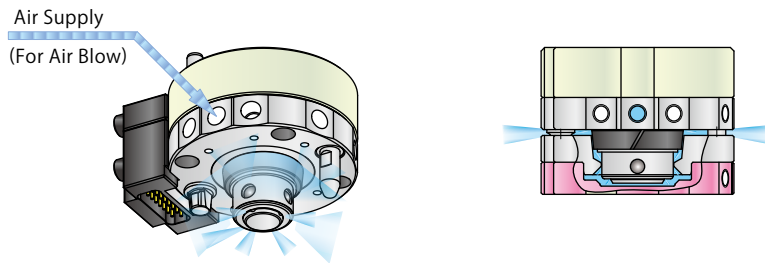

● Circuit Reference

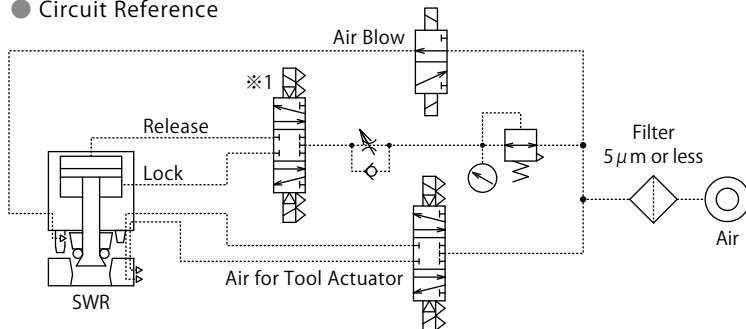

※ 1. For Safety :

In case of using a 2-position solenoid valve, make sure to select the solenoid valve for operating SWR that supplies air pressure to the lock port side when it is not magnetized. Refer to "2) Air Pressure Circuit Reference" on P.77 for the detail.

● Port Option Symbol **F** : With Seat Check Port

Close contact check detects secure connection of the master cylinder and the tool adapter. This prevents a connection error of robotic hand changer.

Close contact check is conducted with the air catch sensor. (Air catch sensor must be installed separately.)

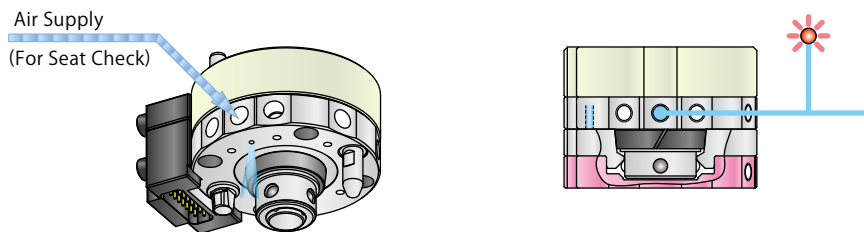

● Circuit Reference

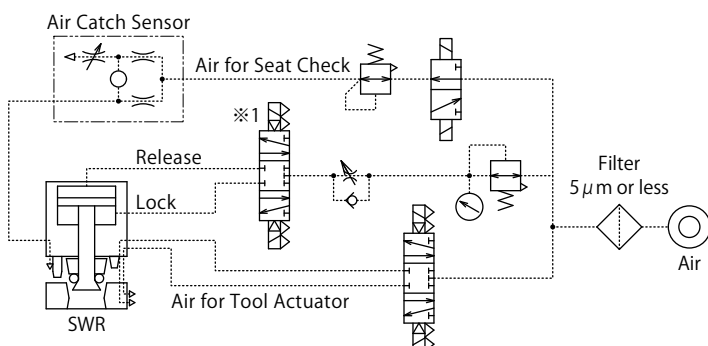

※ 1. For Safety :

In case of using a 2-position solenoid valve, make sure to select the solenoid valve for operating SWR that supplies air pressure to the lock port side when it is not magnetized. Refer to "2) Air Pressure Circuit Reference" on P.77 for the detail.

Joint Option (Air Port Part)

Master Cylinder Model No.

SWR 003 0 - M - - Blank

SWR 007 012 025 050 075 120 230 0 - M - - Blank S

Payload

5 Joint Option Symbol

Tool Adapter Model No.

SWR 003 007 012 025 050 075 0 - T - - Blank

SWR 120 230 0 - T - - Blank S

Payload

5 Joint Option Symbol

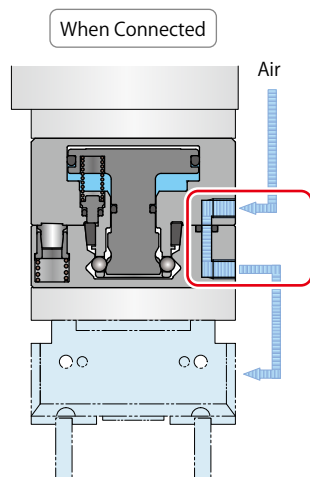

Air Joint Part

Selectable from two air port joint options.

Without Check Valve [Standard]

Joint Option Symbol **Blank**

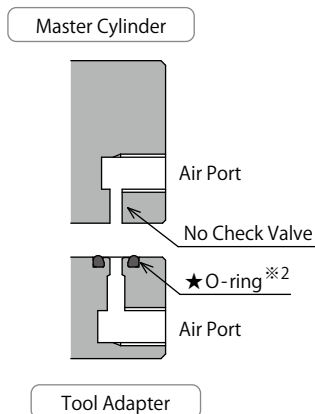

With Check Valve (No check valve option for SWR0030)

Joint Option Symbol **S**

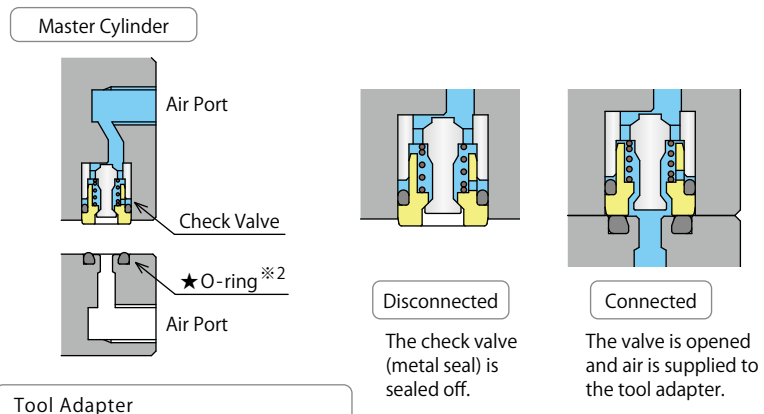

Tool Adapter
SWR0070-T ~ SWR0750-T is **Blank** ※3
SWR1200-T, SWR2300-T is **S** ※4

Notes: ※2. For SWR0500/0750/1200/2300, ★O-ring is installed to the master cylinder side.

Refer to the Joint Structure on External Dimensions (P.31 ~ P.34) for the structure of the check valve option.

※3. For SWR0070 ~ SWR0750, a check valve is installed to the master cylinder side only.

Since there is no check valve for the tool adapter side, the joint option symbol of SWR0030-T ~ SWR0750-T is **Blank**.

※4. For SWR1200, SWR2300 with the check valve option, since the master cylinder has a check valve and the tool adapter side has a simple check valve, the joint option symbol of SWR1200-T, SWR2300-T is **S**.

Locating + Clamp

Locating

Hand · Clamp

Support

Valve · Coupler

Cautions · Others

Robotic Hand Changer

SWR Payload 3kg ~ 360kg

SWR010 Payload 0.5kg ~ 1kg

Manual Robotic Hand Changer

SXR

Pneumatic Location Clamp

SWT

Compact Pneumatic Location Clamp

SWQ

High-Power Pneumatic Pallet Clamp

WVS

● 3kg Payload • 6 Air Port Model SWRY0010

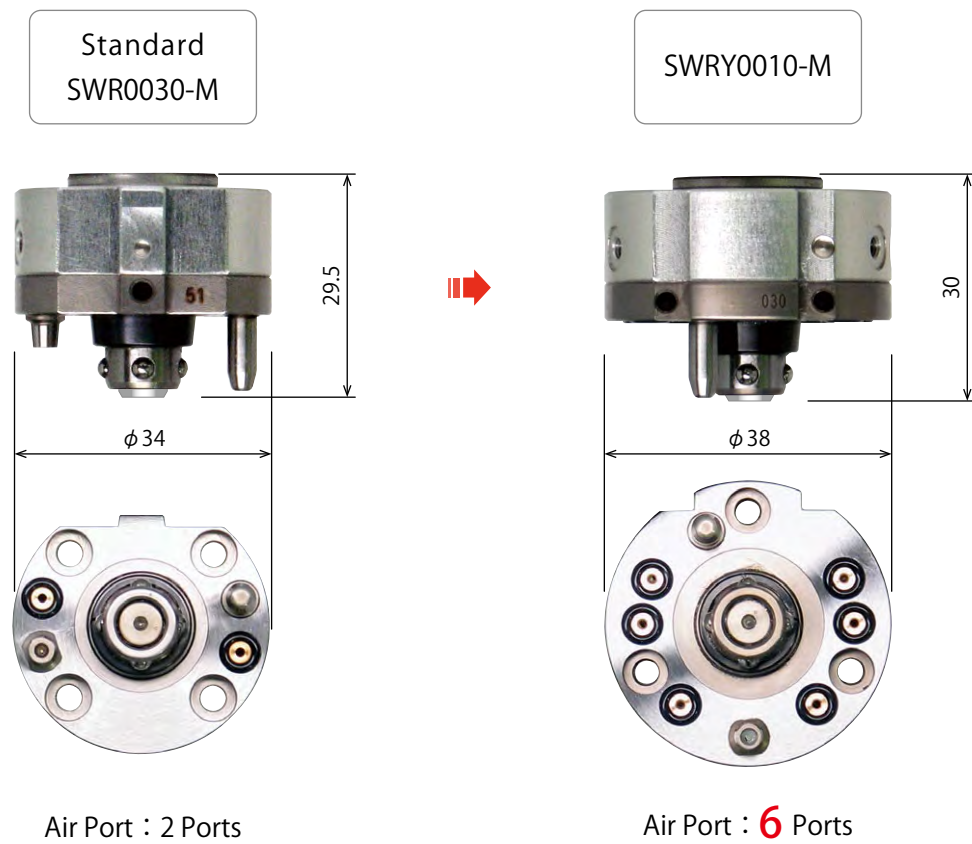

Slight increase in size enables to install 6 air ports in 3kg payload robotic hand changer.

● Model No. Indication : Master Cylinder

SWRY001 0 - M - B

1 2

● Model No. Indication : Tool Adapter

SWRY001 0 - T - B

1 2

1 Design No.

0 : Revision Number

2 External Options (Electrode • Air Joint) Refer to P.37 ~ P.64 for the specifications of the external options.

- Blank** : No Electrode (Standard)
 - B** : Solder Terminal (15 Poles)
 - C01** : Solder Terminal with Cable (15 Poles•Cable Length 1m)
 - C02** : Solder Terminal with Cable (15 Poles•Cable Length 2m)
 - J** : Resin Connector (16 Poles)
 - K** : Compact Electric Power Transmission (4 Poles)
 - R** : Air Joint (3 Ports)
 - U01** : Simple Waterproof Electrode (16 Poles•Cable Length 1m)
 - U02** : Simple Waterproof Electrode (16 Poles•Cable Length 2m)
 - W** : Noncontact Waterproof Electrode Compact Model (Number of Signals: 4•NPN)
 - WX** : Noncontact Waterproof Electrode Compact Model (Number of Signals: 4•PNP) ※1
- ※1. The option symbol 'WX' is only for master cylinder. The option symbol of the tool adapter is 'W' for both NPN/PNP.

● Specifications

Payload	kg	3
Repeatability	mm	0.003
Lift Stroke (Detaching Stroke)	mm	0.8
Allowable Static Moment	Bending	5
	Twisting	12
Air Pressure	Max.	1.0
	Min.	0.4
	Withstanding Pressure	1.5
Operating Temperature	°C	0 ~ 70
Usable Fluid		Dry Air
Weight (Main Body)	Master Side	85
	Tool Side	60
Air Port		M3×0.5×6 Ports

※ Refer to P.37 ~ P.64 for the specifications of the external options.

● Performance Curve

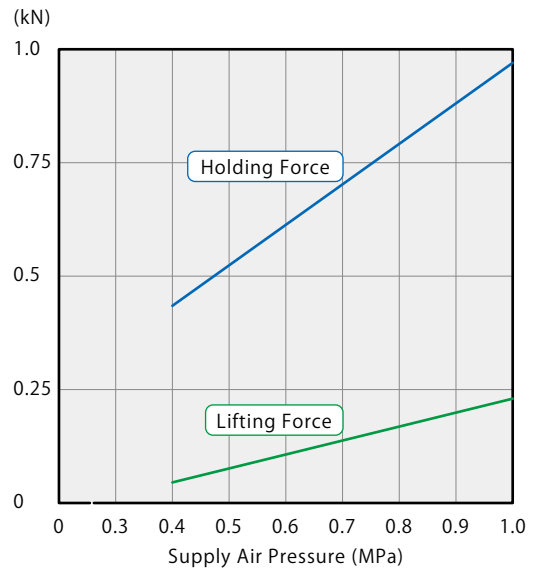

- Locating + Clamp
- Locating
- Hand • Clamp
- Support
- Valve • Coupler
- Cautions • Others

- Robotic Hand Changer
 - SWR Payload 3kg ~ 360kg
 - SWR0010 Payload 0.5kg ~ 1kg
- Manual Robotic Hand Changer
 - SXR
- Pneumatic Location Clamp
 - SWT
- Compact Pneumatic Location Clamp
 - SWQ
- High-Power Pneumatic Pallet Clamp
 - WVS

● SWRY0010 External Dimensions

● External Dimensions (without External Option)

Master Cylinder
SWRY0010-M

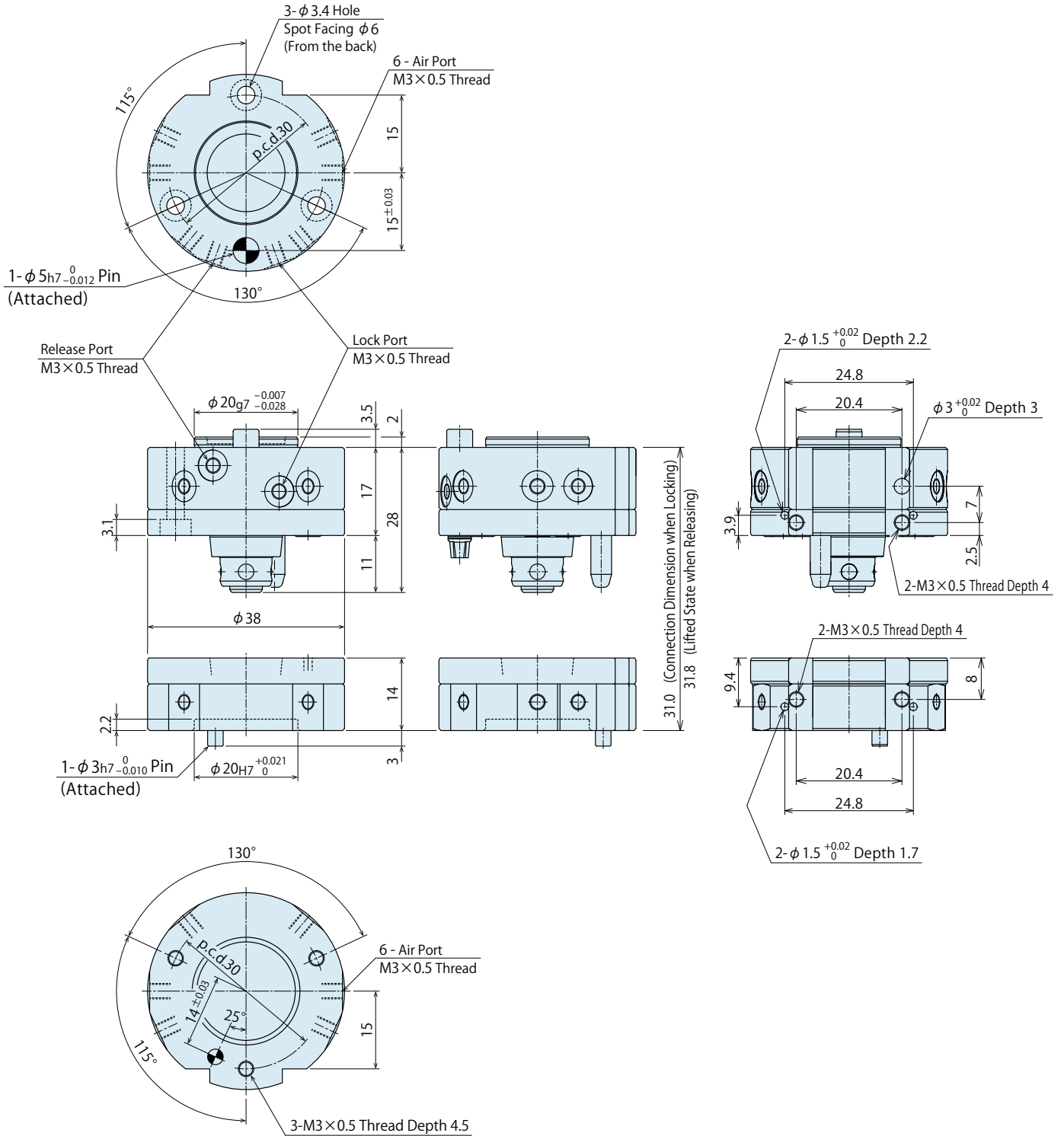

Tool Adapter
SWRY0010-T

External Dimensions of External Options

※ Refer to P.71 for unlisted dimensions.

**Master Cylinder
SWRY0010-M-B**

※ Refer to P.41 for the detailed electrode specifications.

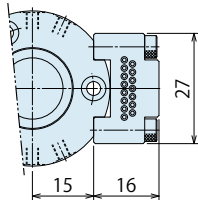

**【For Shipping and Packing】
Breakage Prevention Cover
for Electrode Bar
(Continuity Prevention Cover)**

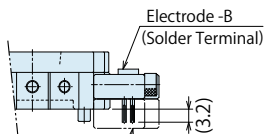
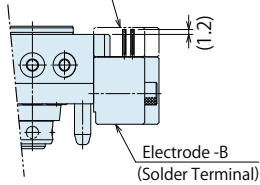

**【For Shipping and Packing】
Breakage Prevention Cover
for Electrode Bar
(Continuity Prevention Cover)**

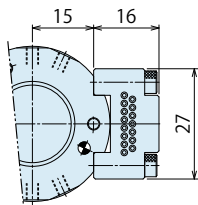

**Tool Adapter
SWRY0010-T-B**

**Master Cylinder
SWRY0010-M-C0**

※ Refer to P.43 for the detailed electrode specifications.

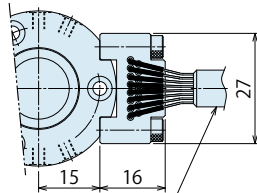

C01 : Cable Length 1m
C02 : Cable Length 2m

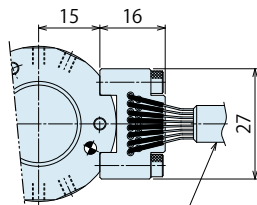
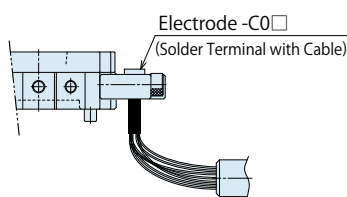
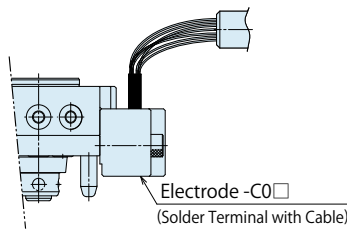

C01 : Cable Length 1m
C02 : Cable Length 2m

**Tool Adapter
SWRY0010-T-C0**

**Master Cylinder
SWRY0010-M-J**

※ Refer to P.37 for the detailed electrode specifications.

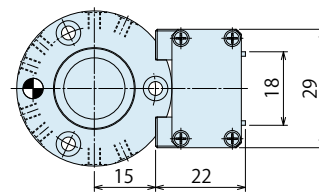

Connector (16 poles : HIROSE ELECTRIC)
DF11-16DP-2DS

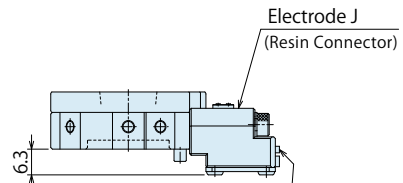
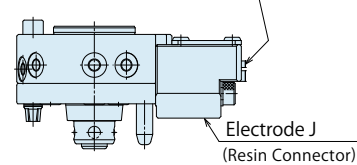

Connector (16 poles : HIROSE ELECTRIC)
DF11-16DP-2DS

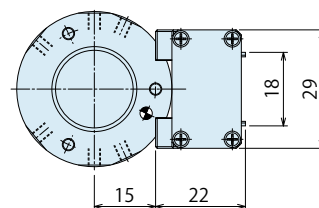

**Tool Adapter
SWRY0010-T-J**

Locating + Clamp

Locating

Hand · Clamp

Support

Valve · Coupler

Cautions · Others

Robotic Hand Changer

SWR Payload 3kg ~ 360kg

SWR0010 Payload 0.5kg ~ 1kg

Manual Robotic Hand Changer

SXR

Pneumatic Location Clamp

SWT

Compact Pneumatic Location Clamp

SWQ

High-Power Pneumatic Pallet Clamp

WVS

● SWRY0010 External Dimensions

● External Dimensions of External Options

※ Refer to P.71 for unlisted dimensions.

Master Cylinder
SWRY0010-M-K

※ Refer to P.53 for the detailed electrode specifications.

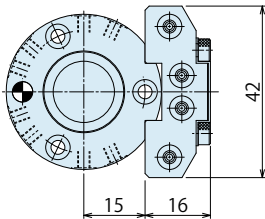

Sold Separately
Optional Cable
SWZ0K0-CL□
Refer to P.55

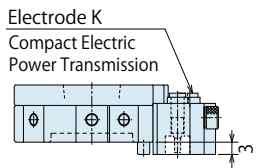
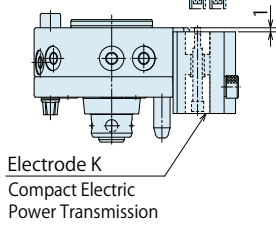

Sold Separately
Optional Cable
SWZ0K0-CL□
Refer to P.55

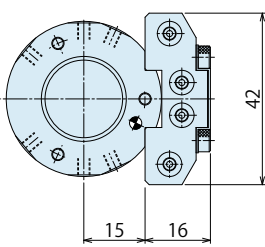

Tool Adapter
SWRY0010-T-K

Master Cylinder
SWRY0010-M-R

※ Refer to P.63 for the detailed air joint specifications.

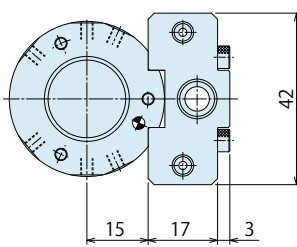
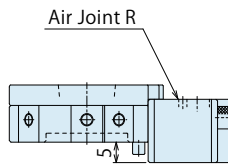
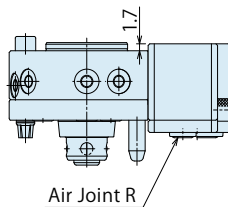
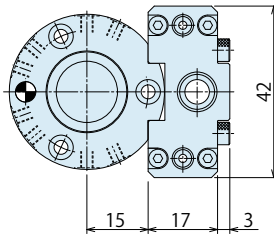

Tool Adapter
SWRY0010-T-R

Master Cylinder
SWRY0010-M-U□

※ Refer to P.47 for the detailed electrode specifications.

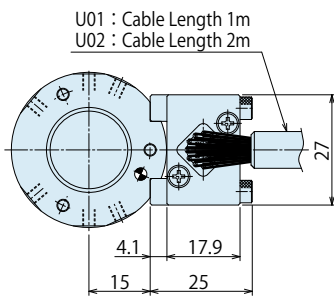
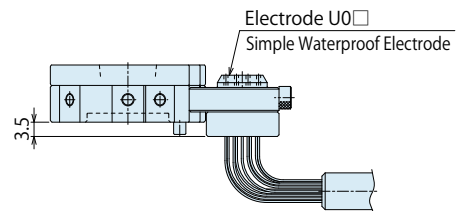
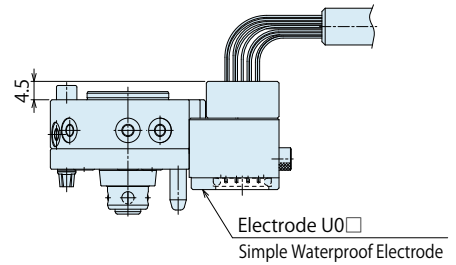
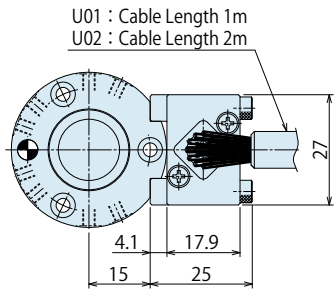

Tool Adapter
SWRY0010-T-U0□

**Master Cylinder
SWRY0010-M-W**

※ Refer to P.59 for the detailed electrode specifications.

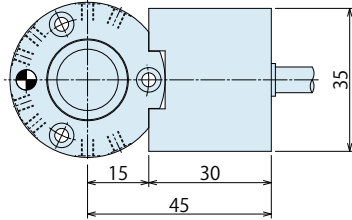

Electrode W/WX

Noncontact Waterproof Electrode
Compact Model

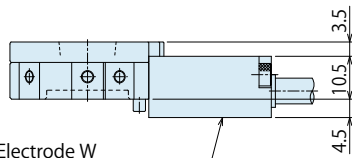
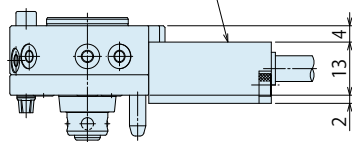

Electrode W

Noncontact Waterproof Electrode
Compact Model

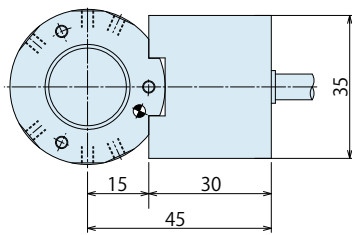

**Tool Adapter
SWRY0010-T-W**

- Locating + Clamp
- Locating
- Hand • Clamp
- Support
- Valve • Coupler
- Cautions • Others

- Robotic Hand Changer
 - SWR Payload 3kg ~ 360kg
 - SWR0010 Payload 0.5kg ~ 1kg
- Manual Robotic Hand Changer
 - SXR
- Pneumatic Location Clamp
 - SWT
- Compact Pneumatic Location Clamp
 - SWQ
- High-Power Pneumatic Pallet Clamp
 - WVS

● **Exclusive Cases** ※ A Part of Exclusive Case Examples. Please contact us for further information.

● **With Center Hole**

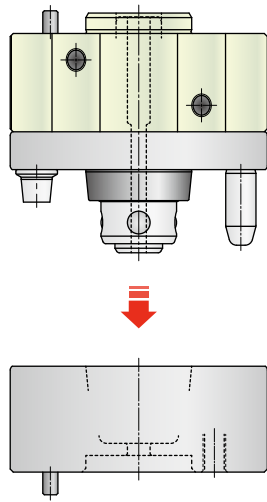

Disconnected

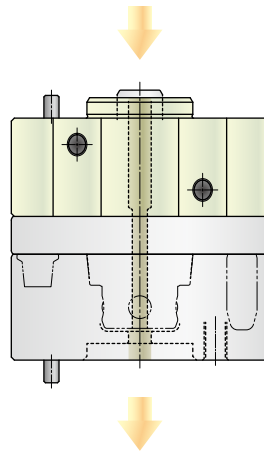

Connected

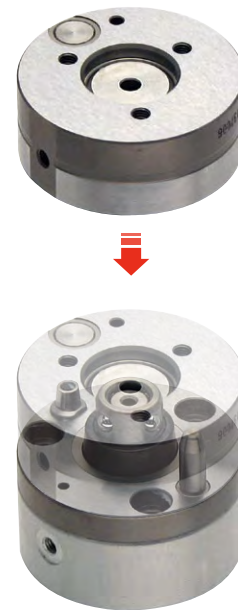

Center hole is provided for photoelectric detection and various purposes.

● **Exclusive Cases** ※ A Part of Exclusive Case Examples. Please contact us for further information.

● **Increase in Payload with SWT Air Locating Clamp**

By using Kosmek Air Locating Clamp SWT, Robotic Hand Changer can be used for larger robots.
It is able to install Kosmek Air Joint as well.

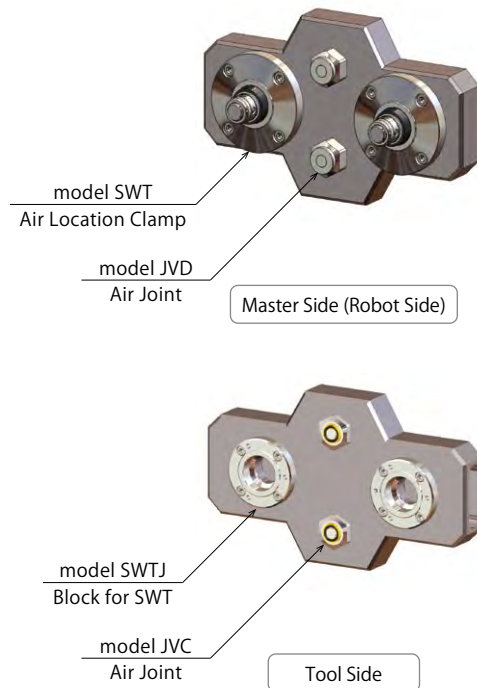
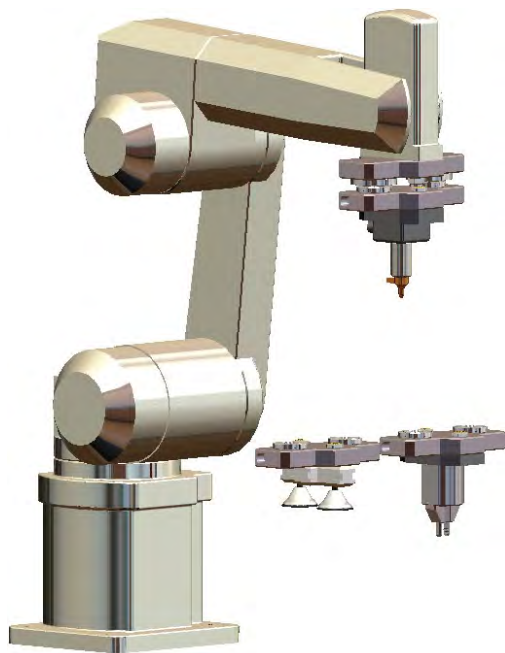

- Locating + Clamp
- Locating
- Hand · Clamp
- Support
- Valve · Coupler
- Cautions · Others

Robotic Hand Changer

- SWR Payload 3kg ~ 360kg
- SWR010 Payload 0.5kg ~ 1kg

Manual Robotic Hand Changer

- SXR

Pneumatic Location Clamp

- SWT

Compact Pneumatic Location Clamp

- SWQ

High-Power Pneumatic Pallet Clamp

- WVS

Cautions

Notes for Design

- 1) Check Specifications
 - Please use each product according to the specifications.
 - Operating Air Pressure as follows :
 - SWR0030, SWRY0010 : Max. 1.0 MPa and Min. 0.4MPa
 - SWR0070 ~ SWR1200 : Max. 1.0 MPa and Min. 0.35MPa
 - SWR2300 : Max. 0.7 MPa and Min. 0.35MPa
- 2) Air Pressure Circuit Reference
 - SWR remains locked (keeps holding a tool) with mechanical lock (spring for maintain). However, for safety, when using a 2-position solenoid valve, make sure to select the solenoid valve for operating SWR that supplies air pressure to the lock port side when it is not magnetized. If air is supplied to the release port when the switch of solenoid valve is turned off, it is very dangerous since SWR may drop the tool (hand).

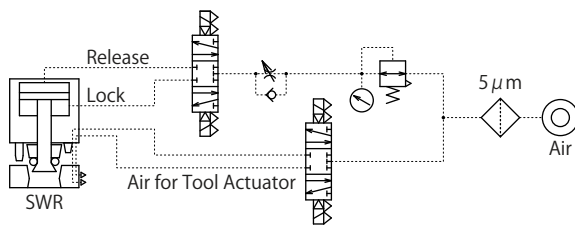

- 3) Operating Environment (External Option (Electrode))
 - Do not use the product in the environment with water · vapor · liquid · scattering of chemicals · explosion · gas with causticity. Also, using in the environment with cutting chips · cutting fluid · dust · spatter scattering may lead to continuity error of electrode. We offer IP67-Compatible Noncontact Waterproof Electrode for the environment with water · vapor · liquid · cutting chips.
- 4) Electrification of Electrodes while Connecting/Disconnecting (External Option (Electrode))
 - If connecting/disconnecting robotic hand changer while energized (hot swapping), there will be a discharge phenomenon (spark phenomenon) between the electrodes opposing each other. The tips of contact probes and electrode bars will be severely worn down due to the phenomenon, and the basis metal might be melted due to oxidation or abrasion of gold-plating leading to conduction failure. Electricity should be shut off while connecting/disconnecting the robotic hand changer. In case of continuous electrification with more than 40 ~ 60% of rated current, it is recommended to use multiple electrodes in a line. (In order to improve durability of contact probes.)
- 5) Note for Single Use of SWR Robotic Hand Changer
 - Applying withstanding pressure without mounting on a robot or a plate leads to damage on the product. Make sure to supply air after setting SWR on a robot or a plate.
- 6) Hand Changing (Attaching/Detaching) in a Horizontal Position
 - When connecting/disconnecting the Robotic Hand Changer in a horizontal position, make sure not to apply excessive moment on master cylinder. Please select an appropriate size of model considering robot payload with allowance fully taken into consideration. When connecting, make sure the tool side has no lifting or tilting that is larger than the allowable position offset range. Also, do not fix it completely on the tool stand, and make a margin (clearance) within the allowable position offset range. Otherwise, this will affect repeatability.

Installation Notes

- 1) Please supply filtered clean dry air.
 - Make sure to supply filtered clean dry air.
 - Oil supply with a lubricator etc. is unnecessary.
- 2) Preparation for Piping
 - The pipeline, piping connector and fixture circuits should be cleaned and flushed thoroughly. The dust and cutting chips in the circuit may lead to fluid leakage and malfunction.
 - There is no filter provided with this product for prevention of contaminants in the air circuit.
- 3) Applying Sealing Tape
 - When using sealing tape, wrap with it 1 to 2 times following the screwing direction. When piping, be careful that contaminant such as sealing tape does not enter in products. Pieces of the sealing tape can cause air leaks and malfunction.
- 4) Notes on Wire/Cable Procedure and Wiring (External Options (Electrode))
 - Make sure to fix the wire and cable so that they are not pulled while a robot is moving or turning around. External force should not be applied on the connector part since it leads to breaking of wire, detaching of connector and contact failure.

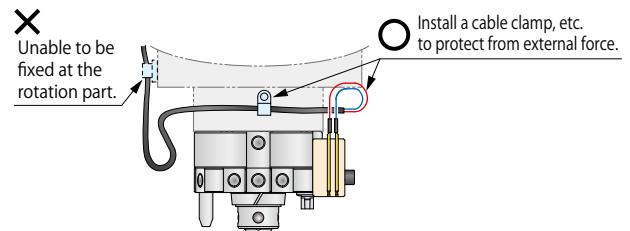

- When allocating each electric signal, imperceptible signal and power signal should be apart. Otherwise noise will be propagated from power signal to imperceptible signal. Also it is the same for wire and cable of external options (electrode). Make sure to keep imperceptible signal from power signal.

5) Installation/Removal of Master Cylinder/Tool Adapter

- Please follow the tightening torque below.

When mounting, use the attached pins and tighten them with bolts evenly not to incline the master cylinder and tool adapter.

	Model No.	Bolt Size	No. of Bolts	Tightening Torque (N·m)
Master Cylinder	SWR0030-M	M3 × 0.5	4	1.3
	SWRY0010-M	M3 × 0.5	3	1.3
	SWR0070-M	M3 × 0.5	4	1.3
	SWR0120-M	M4 × 0.7	4	3.2
	SWR0250-M	M5 × 0.8	4	6.3
	SWR0500-M	M6 × 1	4	10
	SWR0750-M	M6 × 1	6	10
	SWR1200-M	M8 × 1.25	6	25
Tool Adapter	SWR2300-M	M10 × 1.5	6	50
	SWR0030-T	M3 × 0.5	4	1.3
	SWRY0010-T	M3 × 0.5	3	1.3
	SWR0070-T	M4 × 0.7	4	3.2
	SWR0120-T	M4 × 0.7	4	3.2
	SWR0250-T	M5 × 0.8	4	6.3
	SWR0500-T	M6 × 1	4	10
	SWR0750-T	M6 × 1	6	10
	SWR1200-T	M8 × 1.25	6	20
	SWR2300-T	M10 × 1.5	6	50

Do not lose attached pins for installation/removal of the master cylinder/tool adapter.

If not using attached pins, moment quality may not be secured.

6) Installation of Optional Electrode

For electrode installation, apply screw lock glue (equivalent to 1401 made by ThreeBond) on the tip of the mounting bolt and tighten it with the tightening torque shown below.

- M3 Hexagon Socket Bolt : 0.5N · m
- M4 Hexagon Socket Bolt : 1.5N · m

7) Test Run Method

- If supplying a large amount of air just after installation, action time will be extremely fast leading to severe damage on robotic hand changer. Set the speed controller (Meter-in) and gradually supply air pressure.

8) Allowable Offset while Teaching

- Allowable offset of the master cylinder and tool adapter while teaching should be within the range shown below.

Tool adapter and tool placing stand should have space within the range of allowable offset.

① Allowable Position Offset in Horizontal Direction

Model No.	Allowable Offset Amm
SWR0030	±0.8 mm
SWRY0010	±0.8 mm
SWR0070	±0.8 mm
SWR0120	±0.8 mm
SWR0250	±1.0 mm
SWR0500	±1.3 mm
SWR0750	±1.3 mm
SWR1200	±2.0 mm
SWR2300	±2.0 mm

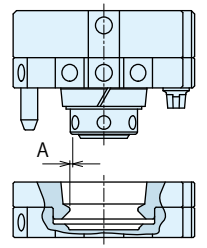

① Horizontal Position Offset

② Allowable Position Offset in Tilt Direction

Model No.	Allowable Offset θ
SWR0030	θ=1.5 deg
SWRY0010	θ=1.5 deg
SWR0070	θ=1.5 deg
SWR0120	θ=1.5 deg
SWR0250	θ=1.2 deg
SWR0500	θ=1.0 deg
SWR0750	θ=1.0 deg
SWR1200	θ=0.9 deg
SWR2300	θ=0.6 deg

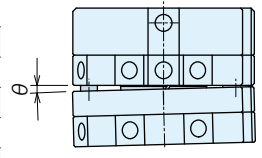

② Tilt Position Offset

③ Allowable Position Offset in Rotation Direction

Model No.	Allowable Offset θ
SWR0030	θ=±3 deg
SWRY0010	θ=±3 deg
SWR0070	θ=±3 deg
SWR0120	θ=±3 deg
SWR0250	θ=±2 deg
SWR0500	θ=±2 deg
SWR0750	θ=±2 deg
SWR1200	θ=±2 deg
SWR2300	θ=±1.5 deg

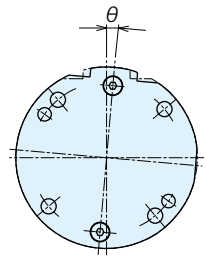

③ Rotation Position Offset

Continuing "Installation Notes" on the Next Page

※ Please refer to P.715 for common cautions. • Notes on Handling • Maintenance/Inspection • Warranty

Cautions

Installation Notes (Continued)

9) Most Suitable Gap between Master Cylinder and Tool Adapter Just Before Connection (When Setting)

- The gap between master cylinder and tool adapter when connecting should be within the range of [Lift Stroke]~[Lift Stroke+0.5mm] shown on P.25. It may not be able to connect with more than the lift stroke + 0.5mm.

10) Most Suitable Gap between Tool Adapter and Tool Placing Stand Just Before Disconnection

- The gap between the tool adapter and tool stand when detaching should be more than [Lift Stroke] shown on P.25. Tool adapter is forcibly detached with detaching (lifting) function of the master cylinder. It is recommended to install cushioning mechanism between the tool adapter and tool stand.

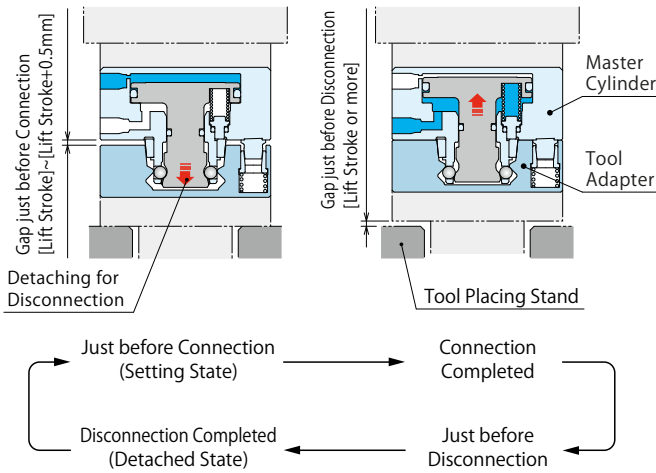

11) Connection Method for -B : Solder Terminal (External Option (Electrode))

- For solder terminal option, the electric signal pin, wire and cable of both master cylinder and tool adapter are connected with soldering. Remove the continuity prevention cover before soldering. At this time, if removing the press-fitted housing of the electric signal pin, install it as shown in the following drawing **【Mounting Height】** considering the height from seating surface.

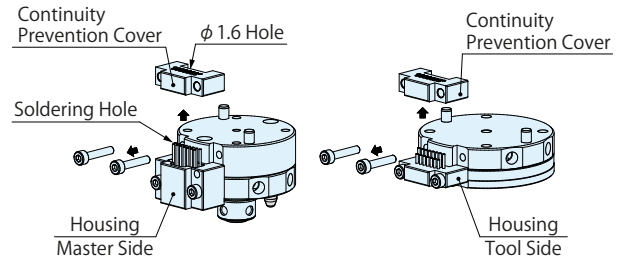

【Mounting Height】

Model : SWR0030/0070/0120/0250/0500/0750/1200/2300

※ Make sure not to tilt, and adjust the height of both ends of the housing.

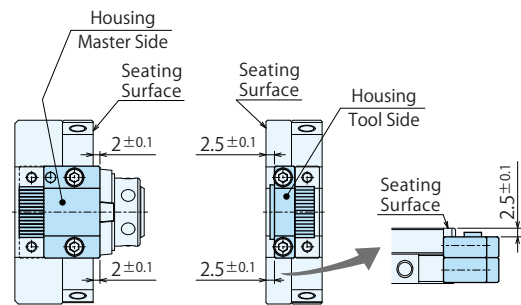

Soldering condition should be : 280°C, within 3 seconds.

Make sure the outer diameter is φ 1.6mm after soldering. If it exceeds φ 1.6mm the continuity prevention cover cannot be installed.

【Recommended Wire Diameter】

Use wires with AWG26 size or smaller diameter. If you need electric current more than allowable flowing current of AWG26, use wires within the rated value of electrode. At this time, soldering hole and attached continuity prevention cover cannot be used. If required, insulate them with a thermal contraction tube etc.

Before installing the continuity prevention cover, apply screw lock glue (equivalent to 1401 made by ThreeBond) on the tip of M3 hexagon socket bolt.

- Tightening Torque of M3 Hexagon Socket Bolt : 0.5N · m

12) Connection Method for -D/E/G/H/J : Connector (External Option (Electrode))

- A Connector must be fully inserted into the electrode. As for -D/E/G/H options, make sure to screw up the connector. If a connector is not fully inserted or screwed up, it will cause contact failure.

13) Notes for using -K : Compact Electric Power Transmission (External Option (Electrode))

- As for Compact Electric Power Transmission option, the electrode probes on both master cylinder and tool adaptor are exchangeable. The electrode probes will be fallen out if pushed from the cable connecting side with power stronger than a certain level. In case the electrode probes are pushed out after connecting the cable, make sure to push them back from the seating surface side before use.

● Cautions

● Maintenance • Inspection

1) Removal of the Product and Shut-off of Pressure Source

- Before removing the product, make sure that the safety devices are in place. Shut off the pressure and power source and make sure no pressure exists in the air and hydraulic circuits.
- Make sure there is no trouble/issue in the bolts and respective parts before restarting.

2) Cleaning of Master Cylinder • Tool Adapter

- If using the product when the taper reference surface or seat check surface of master cylinder/tool adapter are contaminated with dirt, it may lead to locating accuracy failure, malfunction or air leakage. (Do not apply grease on the taper reference surface.)

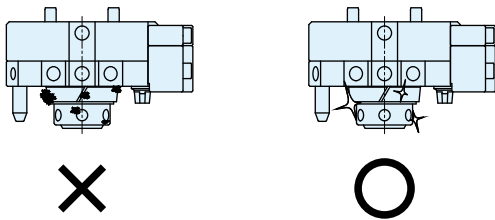

3) Regularly examine and retighten piping, mounting bolts and wires to ensure proper use.

4) Make an inspection before use and regularly.

- If there is dirt or dust on the electric contact part, electric signal is hard to conduct. Wipe it out with a cloth soaked in an organic solvent such as IPA.
- If there is a contact failure while in use, make an inspection mainly of the electricity connection part and clean it out. If the contact probe of master cylinder has abnormality, it has to be replaced. When installing an electrode after removing it, check the mounting height of -B : Solder Terminal connection method on P.79.

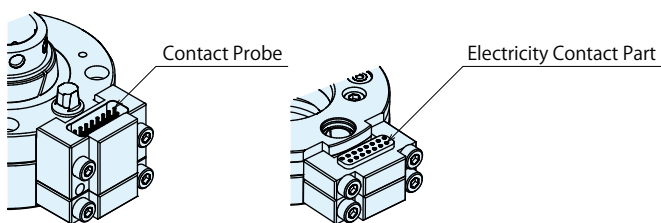

5) Make sure to supply filtered clean dry air.

6) Make sure there is smooth action and no air leaks.

- Especially when it is restarted after left unused for a long period, make sure it can be operated properly. If there is air leak while connecting, please contact us for overhaul and repair.

7) The products should be stored in the cool and dark place without direct sunshine or moisture.

8) Please contact us for overhaul and repair.

Locating + Clamp
Locating
Hand • Clamp
Support
Valve • Coupler
Cautions • Others

Robotic Hand Changer
SWR Payload 3kg ~ 360kg
SWR010 Payload 0.5kg ~ 1kg
Manual Robotic Hand Changer
SXR
Pneumatic Location Clamp
SWT
Compact Pneumatic Location Clamp
SWQ
High-Power Pneumatic Pallet Clamp
WVS

※ Please refer to P.715 for common cautions. • Notes on Handling • Maintenance/Inspection • Warranty

● Cautions

● Notes on Handling

- 1) It should be operated by qualified personnel.
 - The hydraulic machine and air compressor should be operated and maintained by qualified personnel.
- 2) Do not operate or remove the product unless the safety protocols are ensured.
 - ① The machine and equipment can only be inspected or prepared when it is confirmed that the safety devices are in place.
 - ② Before the product is removed, make sure that the above-mentioned safety devices are in place. Shut off the pressure and power source, and make sure no pressure exists in the air and hydraulic circuits.
 - ③ After stopping the product, do not remove until the temperature drops.
 - ④ Make sure there is no trouble/issue in the bolts and respective parts before restarting the machine or equipment.
- 3) Do not touch a clamp (cylinder) while it is working. Otherwise, your hands may be injured.

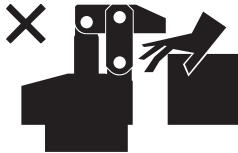

- 4) Do not disassemble or modify.
 - If the equipment is taken apart or modified, the warranty will be voided even within the warranty period.

● Maintenance and Inspection

- 1) Removal of the Machine and Shut-off of Pressure Source
 - Before removing the product, make sure that the safety devices are in place. Shut off the pressure and power source and make sure no pressure exists in the air and hydraulic circuits.
 - Make sure there is no trouble/issue in the bolts and respective parts before restarting.
- 2) Regularly clean the area around the piston rod and plunger.
 - If it is used when the surface is contaminated with dirt, it may lead to packing seal damage, malfunctioning, fluid leakage.

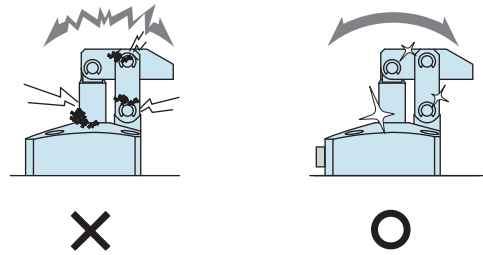

- 3) Regularly clean the reference surfaces (taper reference surface and seating surface) of locating products (SWT/SWQ/SWP/VRA/VRC/VX/VXE/VXF/WVS/VWH/VWM/VWK).
 - Locating products (except VRA/VRC/VX/VXE/VXF and SWR without air blow port) can remove contaminants with the cleaning function. When installing a workpiece or a pallet, make sure there are no contaminants such as thick sludge.
 - Continuous use with dirt on components will lead to locating failure, fluid leakage and malfunction.

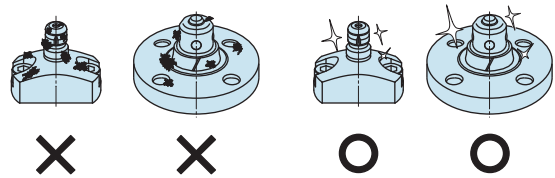

- 4) Regularly tighten pipe, mounting bolt, nut, snap ring, cylinder and others to ensure proper use.
- 5) Make sure the hydraulic fluid has not deteriorated.
- 6) Make sure there is a smooth action without an irregular noise.
 - Especially when it is restarted after left unused for a long period, make sure it can be operated correctly.
- 7) The products should be stored in the cool and dark place without direct sunshine or moisture.
- 8) Please contact us for overhaul and repair.

● Warranty

1) Warranty Period

- The product warranty period is 18 months from shipment from our factory or 12 months from initial use, whichever is earlier.

2) Warranty Scope

- If the product is damaged or malfunctions during the warranty period due to faulty design, materials or workmanship, we will replace or repair the defective part at our expense.

Defects or failures caused by the following are not covered.

- ① If the stipulated maintenance and inspection are not carried out.
- ② Failure caused by the use of the non-confirming state at the user's discretion.
- ③ If it is used or operated in an inappropriate way by the operator. (Including damage caused by the misconduct of the third party.)
- ④ If the defect is caused by reasons other than our responsibility.
- ⑤ If repair or modifications are carried out by anyone other than Kosmek, or without our approval and confirmation, it will void warranty.
- ⑥ Other caused by natural disasters or calamities not attributable to our company.
- ⑦ Parts or replacement expenses due to parts consumption and deterioration. (Such as rubber, plastic, seal material and some electric components.)

Damages excluding from direct result of a product defect shall be excluded from the warranty.

Locating
+
Clamp

Locating

Hand · Clamp

Support

Valve · Coupler

Cautions · Others

Cautions

Installation Notes

Maintenance/
Inspection

Warranty

Company Profile

Company Profile

Our Products

History

Index

Search by
Alphabetical Order

Sales Offices

Sales Offices

Sales Offices across the World

JAPAN HEAD OFFICE Overseas Sales	TEL. +81-78-991-5162	FAX. +81-78-991-8787
	KOSMEK LTD. 1-5, 2-chome, Murotani, Nishi-ku, Kobe-city, Hyogo, Japan 651-2241 〒651-2241 兵庫県神戸市西区室谷2丁目1番5号	
United States of America SUBSIDIARY KOSMEK (USA) LTD.	TEL. +1-630-620-7650	FAX. +1-630-620-9015
	650 Springer Drive, Lombard, IL 60148 USA	
MEXICO REPRESENTATIVE OFFICE KOSMEK USA Mexico Office	TEL. +52-442-161-2347	
	Av. Santa Fe #103 int 59 Col. Santa Fe Juriquilla C.P. 76230 Queretaro, Qro Mexico	
EUROPE SUBSIDIARY KOSMEK EUROPE GmbH	TEL. +43-463-287587	FAX. +43-463-287587-20
	Schleppeplatz 2 9020 Klagenfurt am Wörthersee Austria	
CHINA KOSMEK (CHINA) LTD. 考世美(上海)貿易有限公司	TEL. +86-21-54253000	FAX. +86-21-54253709
	Room601, RIVERSIDE PYRAMID No.55, Lane21, Pusan Rd, Pudong Shanghai 200125, China 中国上海市浦东新区浦三路21弄55号银亿滨江中心601室 200125	
INDIA BRANCH OFFICE KOSMEK LTD - INDIA	TEL. +91-9880561695	
	F 203, Level-2, First Floor, Prestige Center Point, Cunningham Road, Bangalore -560052 India	
THAILAND REPRESENTATIVE OFFICE KOSMEK Thailand Representation Office	TEL. +66-2-300-5132	FAX. +66-2-300-5133
	67 Soi 58, RAMA 9 Rd., Suanluang, Suanluang, Bangkok 10250, Thailand	
TAIWAN (Taiwan Exclusive Distributor) Full Life Trading Co., Ltd. 盈生貿易有限公司	TEL. +886-2-82261860	FAX. +886-2-82261890
	16F-4, No.2, Jian Ba Rd., Zhonghe District, New Taipei City Taiwan 23511 台湾新北市中和區建八路2號 16F-4 (遠東世紀廣場)	
PHILIPPINES (Philippines Exclusive Distributor) G.E.T. Inc, Phil.	TEL. +63-2-310-7286	FAX. +63-2-310-7286
	Victoria Wave Special Economic Zone Mt. Apo Building, Brgy. 186, North Caloocan City, Metro Manila, Philippines 1427	
INDONESIA (Indonesia Exclusive Distributor) PT. Yamata Machinery	TEL. +62-21-29628607	FAX. +62-21-29628608
	Delta Commercial Park I, Jl. Kenari Raya B-08, Desa Jayamukti, Kec. Cikarang Pusat Kab. Bekasi 17530 Indonesia	

Sales Offices in Japan

Head Office Osaka Sales Office Overseas Sales	TEL. 078-991-5162	FAX. 078-991-8787
	〒651-2241 兵庫県神戸市西区室谷2丁目1番5号	
Tokyo Sales Office	TEL. 048-652-8839	FAX. 048-652-8828
	〒331-0815 埼玉県さいたま市北区大成町4丁目81番地	
Nagoya Sales Office	TEL. 0566-74-8778	FAX. 0566-74-8808
	〒446-0076 愛知県安城市美園町2丁目10番地1	
Fukuoka Sales Office	TEL. 092-433-0424	FAX. 092-433-0426
	〒812-0006 福岡県福岡市博多区上牟田1丁目8-10-101	

Global Network

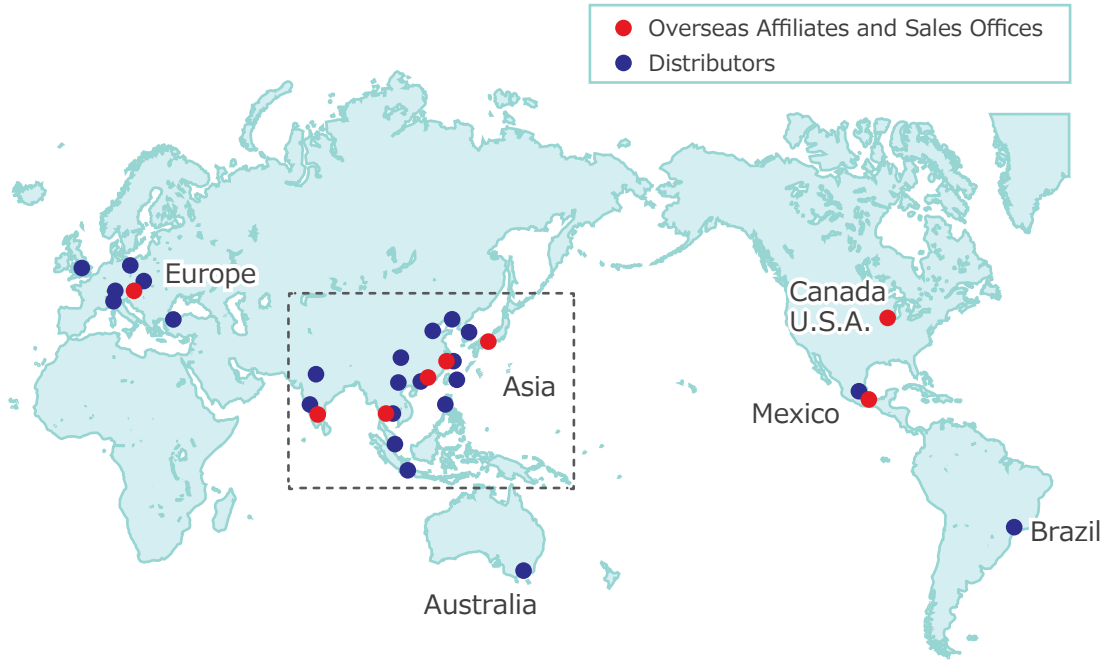

Asia Detailed Map



● FOR FURTHER INFORMATION ON UNLISTED SPECIFICATIONS AND SIZES, PLEASE CALL US.
● SPECIFICATIONS IN THIS CATALOG ARE SUBJECT TO CHANGE WITHOUT NOTICE.

