

**YUKEN**

BASIC HYDRAULICS AND COMPONENTS

# BASIC HYDRAULICS AND COMPONENTS



## YUKEN KOGYO CO.,LTD.

■ Overseas Business Department

Hamamatsucho Seiwa Bldg., 4-8, Shiba-Daimon 1-Chome, Minato-ku, Tokyo  
105-0012 JAPAN  
TEL. +81-3-3432-2110 FAX. +81-3-3436-2344

YUKEN KOGYO CO.,LTD.

**YUKEN KOGYO CO.,LTD.**

## Preface

This book provides an introduction to hydraulics for those unfamiliar with hydraulic systems and components, such as new users, novice salespeople, and fresh recruits of hydraulics suppliers. To assist those people to learn hydraulics, this book offers the explanations in a simple way with illustrations, focusing on actual hydraulic applications.

The first edition of the book was issued in 1986, and the last edition (Pub. JS-100-1A) was revised in 1995. In the ten years that have passed since then, this book has become partly out-of-date. As hydraulic technologies have advanced in recent years, SI units have become standard in the industrial world, and electro-hydraulic control systems and mechatronics equipment are commercially available. Considering these current circumstances, this book has been wholly revised to include SI units, modify descriptions, and change examples of hydraulic equipment.

Conventional hydraulic devices are, however, still used in many hydraulic drive applications and are valuable in providing basic knowledge of hydraulics. Therefore, this edition follows the preceding edition in its general outline and key text. This book principally refers hydraulic products of Yuken Kogyo Co., Ltd. as example, but does mention some products of other companies, with their consent, for reference to equipment that should be understood. We acknowledge courtesy from those companies who have given us support for this textbook.

This edition was originally designed for the Japanese learners and is translated into English, hoping to help assist future engineers of hydraulics in the international community.

Some of the descriptions and figures in Chapters 11, 14, and 15 are extracted from "Oil-Hydraulics - Handbook (Revised in 2001)" issued by the Japan Fluid Power Association (JFPA). We express our deep appreciation to the Association.

### · Units

For US units, use the following conversion formula:-

1 [MPa]	= 145.04 [psi]	1 [cm <sup>3</sup> /rev]	= 6.102×10 <sup>-2</sup> [cu.in/rev]
1 [L/min]	= 0.2642 [U.S.GPM]	1 [kg]	= 2.205 [lbs.]
1 [kW]	= 1.360 [HP]	1 [m]	= 39.37 [in]
1 [N]	= 0.2248 [lbf]	°F	= 9/5 °C + 32

# BASIC HYDRAULICS AND COMPONENTS

## TABLE of CONTENTS

PREFACE	
1 .	WORLD OF HYDRAULICS ..... 1
1-1	Introduction
1-2	Basis of Hydraulics
2 .	HYDRAULIC PUMPS ..... 5
2-1	Comparison of the Pumps
2-2	Piston Pumps
2-3	Vane Pumps
2-4	Gear Pumps
2-5	Screw Pumps
2-6	Reciprocal Pumps
3 .	PRESSURE CONTROL VALVES ..... 16
3-1	Relief Valves
3-2	Sequence Valves
3-3	Counterbalance Valves
3-4	Unloading Relief Valves
3-5	Pressure Reducing Valves/Pressure Reducing and Check Valves
3-6	Brake Valves
3-7	Balancing Valves (Pressure Reducing and Relieving Valves)
3-8	Pressure Switches
4 .	DIRECTIONAL CONTROL VALVES ..... 22
4-1	Classification of Directional Control Valves
4-2	Structure and Characteristics of Directional Valves
4-2-1	Solenoid Operated Directional Valves
4-2-2	Solenoid Controlled Pilot Operated Directional Valves
4-2-3	Poppet Type Solenoid Controlled Pilot Operated Directional Control Valves
4-2-4	Shut-off Type Solenoid Operated Directional Valves (Poppet Type Two-Way Solenoid Operated Directional Valves)
4-2-5	Pilot Operated Directional Valves
4-2-6	Manually Operated Directional Valves
4-2-7	Check Valves
4-2-8	Pilot Operated Check Valves
4-2-9	Multiple Control Valves
5 .	FLOW CONTROL VALVES ..... 32
5-1	Restrictors/One Way Restrictors
5-2	Flow Control Valves/Flow Control and Check Valves
5-3	Deceleration Valves/Deceleration and Check Valves
5-4	Feed Control Valves
5-5	Pilot Operated Flow Control and Check Valves
6 .	MODULAR VALVES ..... 37
7 .	LOGIC VALVES ..... 38
8 .	PROPORTIONAL ELECTRO-HYDRAULIC CONTROL VALVES ..... 41
8-1	Proportional Electro-Hydraulic Pilot Relief Valves
8-2	Proportional Electro-Hydraulic Relief Valves
8-3	Proportional Electro-Hydraulic Relieving and Reducing Valves
8-4	Proportional Electro-Hydraulic Flow Control (and Check) Valves

8-5	Proportional Electro-Hydraulic Flow Control and Relief Valves	
8-6	Proportional Electro-Hydraulic Directional and Flow Control Valves	
8-7	Power Amplifiers For Proportional Electro-Hydraulic Control Valves	
8-8	Setting Adjusters	
8-9	Circuit Example of Proportional Electro-Hydraulic Control Valves	
8-10	Hybrid Proportional Electro-Hydraulic Control Valves	
9.	SERVOMECHANISM & SERVO VALVES	49
9-1	Servomechanism (Tracking Mechanism)	
9-2	Servo Valve Selection	
9-3	Electro-Hydraulic Two-Stage Servo Valves	
9-4	Direct Drive Servo Valves	
9-5	Servo Amplifiers	
9-6	Sensors	
9-7	Hydraulic Power Source	
9-8	Servo Systems with Pump Speed Control	
9-9	Related Terms	
10.	ACTUATORS	58
10-1	Hydraulic Cylinders	
10-2	Hydraulic Motors	
10-3	Oscillating Motors	
11.	HYDRAULIC ACCESSORIES	63
11-1	Filters	
11-2	Accumulators	
11-3	Heat Exchangers	
11-4	Measuring Instruments	
11-5	Valves	
11-6	Others	
12.	HYDRAULIC UNITS	71
12-1	Reservoirs	
12-2	Others	
13.	TROUBLESHOOTING FOR HYDRAULIC EQUIPMENT	73
14.	HYDRAULIC FLUIDS	75
14-1	Selection	
14-2	Petroleum-Based Fluid	
14-3	Viscosity	
14-4	Contamination Control	
14-5	Application Limit	
14-6	Contamination Measurement Instruments	
14-7	Fire Resistance Fluid	
14-8	Biodegradable Fluid	
15.	HYDRAULIC CIRCUITS	82
15-1	Unload Circuits	
15-2	Pressure Control Circuits	
15-3	Speed Control Circuits	
15-4	Filter Circuits	
15-5	Synchronizing Circuits	
15-6	Intensifying Circuits	
15-7	Brake Circuits	
15-8	Closed Circuits	
Appendix:	Main Formulas	92

# WORLD OF HYDRAULIC DRIVE

- 1-1 Introduction
- 1-2 Basis of Hydraulics

## 1-1 Introduction

“Hydraulics” is one of drive systems to control machinery and equipment, comparable with pneumatics and electricity. It was in the early 1900’s that practical hydraulic applications were first seen in the marketplace. A hundred years before that, “water hydraulics,” the origin of the fluid power systems, emerged. Figure 1.1 traces the development history of some typical water and oil hydraulics. Recently, production machinery and their drive systems have been required to be environmentally friendly; “water hydraulics” is attracting attention again because of its cleanliness and safety.

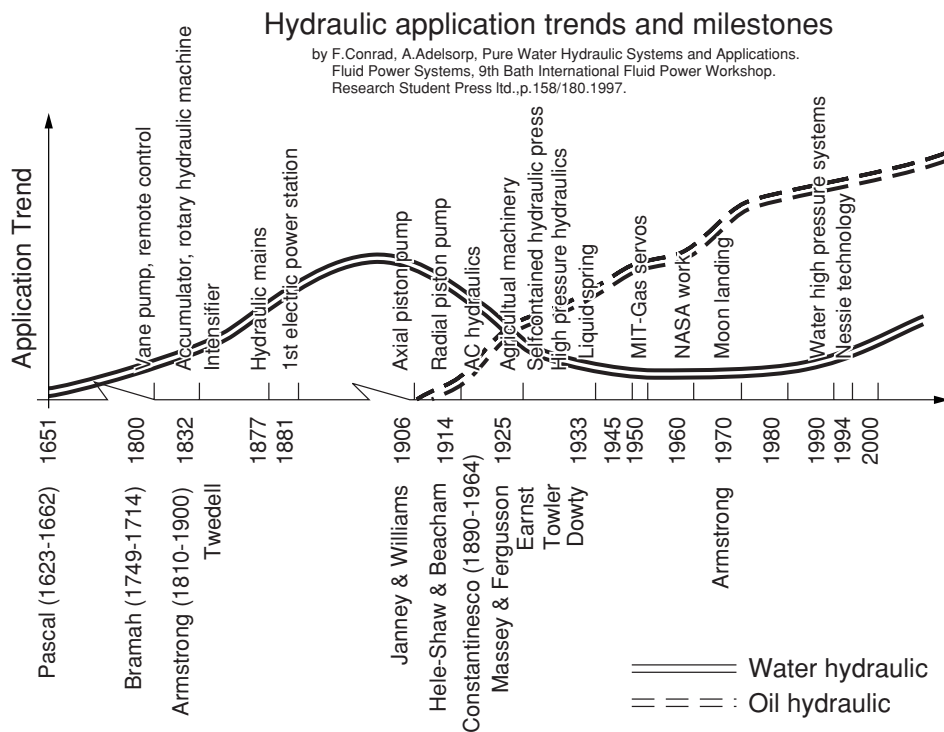

Fig. 1.1 Hydraulic Application Trends and Milestones

- |                                                                                                                                                                                                                                                                                                                                                                                                                                                                                                                                                                                                |                                                                                                                                                                                                                                                                                                                                                                                                                                                                                            |
|------------------------------------------------------------------------------------------------------------------------------------------------------------------------------------------------------------------------------------------------------------------------------------------------------------------------------------------------------------------------------------------------------------------------------------------------------------------------------------------------------------------------------------------------------------------------------------------------|--------------------------------------------------------------------------------------------------------------------------------------------------------------------------------------------------------------------------------------------------------------------------------------------------------------------------------------------------------------------------------------------------------------------------------------------------------------------------------------------|
| <ol style="list-style-type: none"> <li>1. Hydrostatics principles : Archimedes (287~212 B.C.)</li> <li>2. Bases of hydrodynamics : Galileo (1564~1642)</li> <li>3. Hydrostatic laws : Blaise Pascal (1623~1662)<br/>                 . . . Force multiplier [Pascal’s principle; 1653]</li> <li>4. Patent application for the water hydraulic press machine :<br/>                 Joseph Bramah + Henry Maudsley (<i>self-seal</i>)</li> <li>5. Water hydraulic crane, water hydraulic accumulator, manufacturing<br/>                 plant using water hydraulic drive systems :</li> </ol> | <ol style="list-style-type: none"> <li>1845-1849, William Armstrong (1810~1900)</li> <li>6. Fluid power (water hydraulics) supply company :<br/>                 1884, The London Hydraulic Power Company</li> <li>7. Power transmission system : J.W.Hall, Pittler, Lentz, Manley</li> <li>8. Axial piston pump : 1902-1906, Harvey Williams + Reynolds Janney</li> <li>9. Radial piston pump : H.S.Hele-Shaw</li> <li>10. Pressure balanced vane pump : 1925, Harry F.Vickers</li> </ol> |
|------------------------------------------------------------------------------------------------------------------------------------------------------------------------------------------------------------------------------------------------------------------------------------------------------------------------------------------------------------------------------------------------------------------------------------------------------------------------------------------------------------------------------------------------------------------------------------------------|--------------------------------------------------------------------------------------------------------------------------------------------------------------------------------------------------------------------------------------------------------------------------------------------------------------------------------------------------------------------------------------------------------------------------------------------------------------------------------------------|

Hydraulics, which owes much to the high lubricity of mineral oils being used as working fluids, offer compact, high-power, and easy-to-control system components in various industrial fields. Table 1.1 shows shipments of hydraulic products per applicable industrial field, based on survey data from the Japan Fluid Power Association. In 2004, total shipments exceeded 270 billion yen, excluding hydraulic products manufactured in-house by construction machinery suppliers and power steering pumps for automobiles.

**Table 1.1 Shipments of Hydraulic Equipment per Applicable Field**

(Calendar Year Basis)

(Unit: 1 Million Yen. Figures in brackets indicate the percentage shares.)

Applicable Field	1999	2000	2001	2002	2003	2004
Civil Engineering Machinery	77,387 (36.8)	85,350 (36.3)	74,101 (35.8)	74,267 (38.2)	93,164 (39.8)	113,824 (41.3)
Agricultural Machinery	7,625 ( 3.6)	8,045 ( 3.4)	7,548 ( 3.6)	7,745 ( 4.0)	8,052 ( 3.4)	10,214 ( 3.7)
Plastic Processing Machinery	9,649 ( 4.6)	10,906 ( 4.6)	6,469 ( 3.1)	7,045 ( 3.6)	8,916 ( 3.8)	8,207 ( 3.0)
Machine Tools	18,143 ( 8.6)	20,869 ( 8.9)	18,120 ( 8.8)	13,987 ( 7.2)	17,775 ( 7.6)	22,236 ( 8.1)
Primary Metal Processing Machinery	4,829 ( 2.3)	4,190 ( 1.8)	4,400 ( 2.1)	4,257 ( 2.2)	5,074 ( 2.2)	6,843 ( 2.5)
Secondary Metal Processing Machinery	7,794 ( 3.7)	8,421 ( 3.6)	7,518 ( 3.6)	5,936 ( 3.1)	6,727 ( 2.9)	8,339 ( 3.0)
Automobiles (Specially-Equipped Vehicles)	8,245 ( 3.9)	9,127 ( 3.9)	7,514 ( 3.6)	5,445 ( 2.8)	6,530 ( 2.8)	7,174 ( 2.6)
Industrial Vehicles	8,167 ( 3.9)	11,508 ( 4.9)	9,957 ( 4.8)	8,480 ( 4.4)	9,239 ( 3.9)	10,935 ( 4.0)
Ships	11,087 ( 5.3)	9,870 ( 4.2)	9,610 ( 4.6)	8,892 ( 4.6)	9,243 ( 4.0)	9,188 ( 3.3)
Others	57,620 (27.4)	66,936 (28.5)	61,827 (29.9)	58,435 (30.0)	69,263 (29.6)	78,596 (28.5)
<b>Total</b>	<b>210,546(100.0)</b>	<b>235,222(100.0)</b>	<b>207,064(100.0)</b>	<b>194,489(100.0)</b>	<b>233,983(100.0)</b>	<b>275,556(100.0)</b>

Survey by the Japan Fluid Power Association

Chemical machinery is included in "Plastic Processing Machinery," and industrial robots are in "Others."

According to the statistics, the global market scale for hydraulic products is estimated at approximately two trillion yen. The market is shared equally among North America, the EU countries, and Asian countries including Japan.

The advantages of hydraulics are as follows.

- (1) Allows easy speed and position control;
- (2) Facilitates stepless power control;
- (3) Easily changes directions of movement;
- (4) Capable of accumulating energy;
- (5) Smoothly provides safety mechanisms, and;
- (6) Allows for combination with electric controls.

Compared to pneumatics and water hydraulics, oil hydraulics is:

- (1) Superior in respect to lubricity and rust resistance and easy to maintain;
- (2) Able to provide compact systems that operate under high pressures, and;
- (3) Superior to pneumatics in respect to the rigidity of control and response speed.

Basic components to be used in hydraulic systems are categorized as follows.

- (1) Energy converters (hydraulic pumps, motors, and cylinders)
- (2) Energy controllers (directional, pressure, and flow control valves)
- (3) Accessories (reservoirs, filters, accumulators, sensors, etc.)

A power source (hydraulic package or unit) for practical systems consists of a hydraulic pump, a motor, and a reservoir, as shown in Fig. 1.2. Depending on the required accuracy and operability, control valves, such as proportional electro-hydraulic control valves and servo valves, are also incorporated in the systems. Recently, systems have become available that drive hydraulic pumps with servo motors and adjust the pump speed to control the flow and pressure. Figure 1.3 shows a circuit example of basic hydraulic components.



Fig. 1.2 Hydraulic Unit

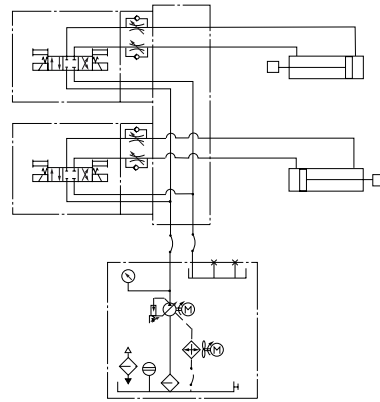
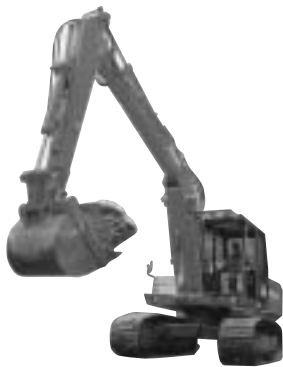

Fig. 1.3 Circuit Example

Hydraulics is applied in a wide range of industries: from construction machinery, automobiles, and airplanes (outdoor) to machine tools and press machines (indoor). Typical applications in each industrial field are listed below. Figure 1.4 shows photos of some of the applications.

For details of the actual applications, refer to “*Yuatsu kudō no sekai - yuatsu nara kōsuru* [The world of hydraulic drives — How hydraulics works]” published by the Japan Fluid Power System Society.

- (1) Construction machinery: excavators, cranes, wheel loaders, and bulldozers
- (2) Agricultural/forestry machinery: tractors, combines, rice planting machines, lawn mowers, and logging machines
- (3) Material processing/forming machinery: steel mill, machine tools, and plastic processing, die casting, press, and sheet metal processing machines
- (4) Automobiles: power steering, transmissions, brake systems, and accessories for transport vehicles
- (5) Industrial and special-purpose vehicles: fork lifts, platform vehicles, garbage trucks, concrete mixer trucks, concrete pump trucks, and accessories for transport vehicles (wing roofs and tail lifts)
- (6) Ships/fishing machinery: steering, propulsion machinery, and deck cranes
- (7) Aerospace machinery: steering, brake systems, and landing gear
- (8) Testing machinery/simulator: vibration testers, flight simulators, and amusement machines
- (9) Special equipment: hydraulic lifts, vibration control systems for high-story buildings and trains, sluice gates, crushers, and compactors



Excavator



Wheel Loader



Steel Mill



Machine Tool



Injection Molding Machine



NC Press

Fig. 1.4 Hydraulic Applications

## 1-2 Basis of Hydraulics

Hydraulic systems transfer power by feeding a hydraulic fluid from a closed vessel with variable displacement to another closed vessel. This section explains “pressure” as the basis of hydraulic power. It is explained in accordance with Pascal’s principle. Also, “flow rates” and “hydraulic power” are explained by the calculation of “forces” and “speeds” of a hydraulic cylinder.

### 1-2-1 Pascal’s Principle

A static fluid in a closed vessel has the following characteristics, as stated by Pascal’s principle.

- (1) Pressure works on a plane at a right angle.
- (2) Pressure is transmitted equally in all directions.
- (3) Pressure applied on part of a fluid is transmitted throughout the fluid equally.

Pressure  $P$  can be expressed by the following formula as a force per unit area.

$$P = F/A$$

$P$  [Pa (psi)]: Pressure,  $F$  [N (lbf)]: Applied force,  
 $A$  [ $m^2$  ( $in^2$ )]: Area where the force is applied

Figure 1.5 shows a force multiplier based on Pascal’s principle. The force multiplier is a closed vessel having different movable pistons positioned at both ends. Pressures everywhere in the vessel are equal; thus, the formula  $P = F_1/A_1 = F_2/A_2$  is derived, accordingly resulting in  $F_2 = F_1 \times A_2/A_1$ . The force on the larger sectional area  $F_2$  is multiplied by the ratio to the smaller sectional area where the force  $F_1$  is applied. The subscripts 1 and 2 indicate the larger and smaller sections of the pistons, respectively. The traveling distance of the piston is proportional to the multiplicative inverse of its ratio of the cross sectional area ( $A_1/A_2$ ); therefore, the piston with the larger cross sectional area travels a smaller distance. The traveling distance per unit time, or the product of the speed and the cross sectional area, is the flow rate.

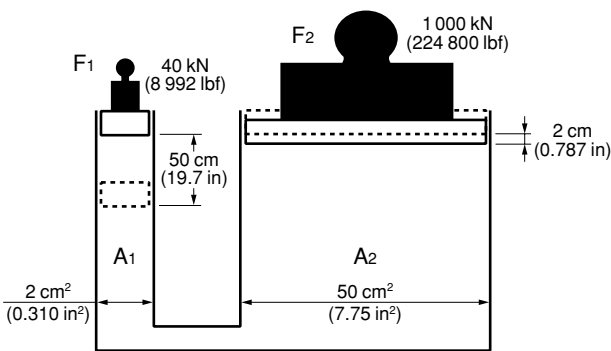

Fig. 1.5 Force Multiplier

### 1-2-2 Force and Speed of Hydraulic Cylinders

When hydraulic flow enters into a closed vessel with a movable piston, the piston is moved by the force applied to its surfaces. This is the principle of hydraulic cylinder operation. The cylinder force and speed are expressed by the following equations.

$$\text{Cylinder Force} = \text{Pressure} \times \text{Cylinder Area}$$

$$\text{Cylinder Speed} = \text{Inlet Flow Rate} / \text{Cylinder Area}$$

The force and speed at the piston and rod sides are shown in Fig. 1.6.

The power of the cylinder, or output [kW (HP)], is the product of the force and the traveling distance per unit time, as shown in the expression below.

$$\begin{aligned} \text{Cylinder Output Power} &= \text{Force} \times \text{Speed} \\ &= (\text{Pressure} \times \text{Cylinder Area}) \\ &\quad \times (\text{Inlet Flow Rate} / \text{Cylinder Area}) \\ &= \text{Pressure} \times \text{Inlet Flow Rate} \end{aligned}$$

This is generally called the hydraulic power.

#### ● Force

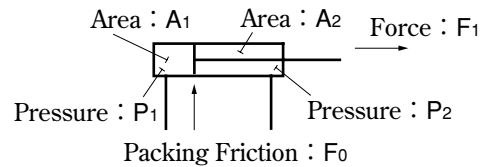

$$\begin{aligned} F_1 &= 0.1 (P_1 \cdot A_1 - P_2 \cdot A_2) - F_0 \quad (\text{kN}) \\ F_1 &= (P_1 \cdot A_1 - P_2 \cdot A_2) - F_0 \quad (\text{lbf}) \end{aligned}$$

$$\left[ \begin{array}{l} \text{Unit } P_1, P_2 : \text{MPa (psi)} \\ A_1, A_2 : \text{cm}^2 (\text{in}^2) \end{array} \right]$$

#### ● Speed

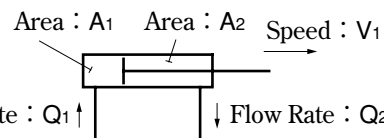

$$Q_1 = \frac{6}{1000} \cdot V_1 \cdot A_1 \quad Q_1 = 3.117 \cdot V_1 \cdot A_1$$

$$V_1 = \frac{1000}{6} \cdot \frac{Q_1}{A_1} \quad V_1 = \frac{1}{3.117} \cdot \frac{Q_1}{A_1}$$

$$Q_2 = \frac{6}{1000} \cdot V_1 \cdot A_2 = \frac{A_2}{A_1} \cdot Q_1 \quad Q_2 = 3.117 \cdot V_1 \cdot A_2 = \frac{A_2}{A_1} \cdot Q_1$$

$$\left[ \begin{array}{l} \text{Unit } Q_1, Q_2 : \text{L/min} \\ V_1 : \text{mm/s} \\ A_1, A_2 : \text{cm}^2 \end{array} \right]$$

$$\left[ \begin{array}{l} \text{Unit } Q_1, Q_2 : \text{U.S.GPM} \\ V_1 : \text{ft/s} \\ A_1, A_2 : \text{in}^2 \end{array} \right]$$

Fig. 1.6 Force and Speed of Hydraulic Cylinders



# 2

# HYDRAULIC PUMPS

- 2-1 Comparison of the Pumps
- 2-2 Piston Pumps
  - Axial Piston Pumps, Radial Piston Pumps
- 2-3 Vane Pumps
  - Fixed Displacement: Single Pumps, Multiple Pumps
  - Variable Displacement: Single Pumps, Multiple Pumps
- 2-4 Gear Pumps
- 2-5 Screw Pumps
- 2-6 Reciprocal Pumps

Hydraulic pumps convert mechanical energy, such as the rotations of motors or engines, to fluid energy. They are called positive displacement pumps and are distinguished from the centrifugal types, such as water pumps and fans, because flow and pressure energies are generated in a closed space.

## 2-1 Comparison of the Pumps

Typical hydraulic pumps fall into three categories: piston, vane, and axial. Tables 2.1 and 2.2 show characteristics and structures and specifications of the respective pumps.

Table 2.1 Characteristics of the Pumps

Type	Piston Pumps	Vane Pumps	Gear Pumps
Structure			
Operation Principle	Expansion and compression of a volume in a cylinder block with the piston stroke	Expansion and compression of volumes between the vanes and the cam ring	Movement of volumes between tooth spaces and the casing (the external gear pump is shown.)
Efficiency	<ul style="list-style-type: none"> <li>• Generally the highest.</li> <li>• The valve plate is easily damaged and efficiency drops as the plate wears out.</li> </ul>	<ul style="list-style-type: none"> <li>• Generally low.</li> <li>• Can be compensated when the vane wears out.</li> </ul>	<ul style="list-style-type: none"> <li>• Generally low.</li> <li>• Drops as the gear wears out.</li> </ul>
Contamination Resistance	Highly susceptible to foreign substances in oil.	Susceptible to foreign substances in oil, but less so than piston pumps.	Susceptible to foreign substances in oil, but hardly susceptible when the pumps are low pressure types.
Suction Ability	Low.	Middle.	High.
Variable Displacement Type	Easy to convert by changing the angle of the swash plate or bent axis.	Can be converted by changing the eccentricity of the cam ring for the unbalanced type.	Difficult.
Size and price	Generally large, heavy, and expensive.	Smallest and relatively inexpensive.	Small, light, and inexpensive.

Table 2.2 Specifications

	Max. Operating Press. MPa (psi)	Max. Displacement cm <sup>3</sup> /rev (cu.in./rev)	Max. Shaft Speed r/min	Overall Efficiency %
Axial Piston Pump	45 (6 527)	1 000 (61.0)	5 600	85~95
Radial Piston Pump	70 (10 153)	500 (30.5)	2 900	80~92
Vane Pump	40 (5 802)	350 (21.3)	4 200	75~90
Gear Pump	35 (5 076)	500 (30.5)	6 000	75~90

Source: *Shinban yukūatsu binran* [Revised hydraulics handbook], 1989, edited by the Japan Hydraulics and Pneumatics Society, published by Ohmsha Ltd.  
Some of the maximum working pressure and rotation speed values are cited from the latest catalogue.

## 2-2 Piston Pumps

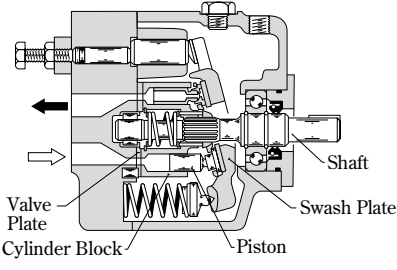
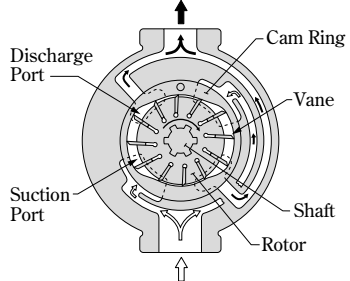
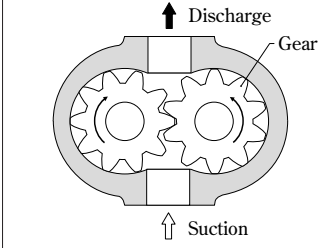
These pumps assure high performance in high pressure operation, compared to the other types, and are easy to convert to the variable displacement type. Thus, they can operate with various control types. The piston pumps provide advantages including: (1) high efficiency; (2) ease of operation at high pressure; (3) ease of conversion to the variable displacement type, and; (4) various applicable control types.

The pumps are categorized into axial, radial, and reciprocal piston types. This section explains the axial piston type, which is most widely applied in industrial machinery, from low-/middle-pressure general industrial machines to high-pressure press machines and construction machines.

### 2-2-1 Axial Piston Pumps

These pumps have pistons installed in parallel, or axially, with the pump shaft. The pumps are subcategorized into the swash plate type and the bent axis type according to the piston stroke mechanism, as shown in Figs. 2.1 and 2.2.

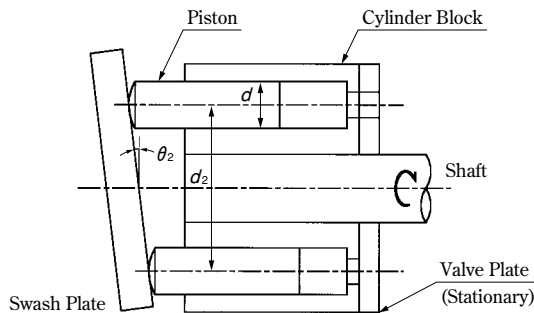

Fig. 2.1 Swash Plate Type

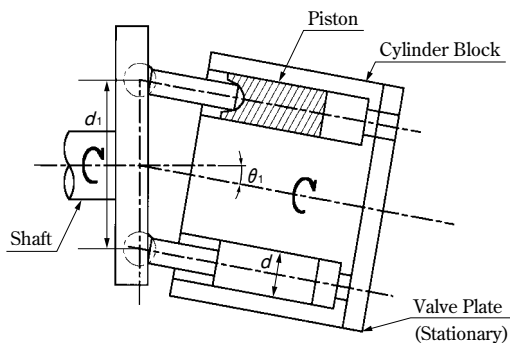

Fig. 2.2 Bent Axis Type

For both the types, pump displacement depends on the stroke of the pistons in the cylinder block. The displacement at the maximum angle of the swash plate or the bent axis represents the pump size. The pumps operate with the cylinder block rotating on the shaft. The cylinder block contacts with and rotates on the valve plate (or port plate), which is fixed opposite to the piston, to provide

alternate suction and discharge strokes. Some of the swash plate type axial piston pumps have a fixed cylinder block and a rotating swash plate, which rotates so that the piston moves. This type uses a check valve in each cylinder to switch suction and discharge.

The displacement of the piston pumps can be changed by adjusting the angle of the swash or bent axis. The swash plate type allows easier adjustment of the angle; thus, it is generally used as a variable displacement piston pump. Figure 2.3 shows the appearances of the swash plate type variable displacement pumps (A and A3H series) and a graphic symbol of the variable displacement piston pump.

A Series



A3H Series

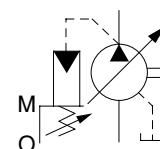

Graphic Symbol

Fig. 2.3 Swash Plate Type Variable Displacement Pumps

The variable displacement piston pumps are based on pressure compensator control (Table 2.4). When the discharge pressure rises to a preset level, the compensator valve is actuated to reduce the discharge pressure and feed it to the control piston. The control piston reduces the angle of the swash plate to decrease the output flow and keep the pressure constant. This control type eliminates the necessity for a relief valve to be installed for the maximum pressure in fixed displacement pump circuits. Figure 2.4 shows the typical characteristics of “A-series variable displacement pumps with pressure compensator control type (A16-01).” The performance characteristic curve indicates that the pumps maintain high efficiency of 96 % at a high pressure of 20 MPa (2 901 psi). When the pressure exceeds 20 MPa (2 901 psi), the flow rate starts to decline (cut-off point). At a pressure of 21 MPa (3 046 psi), the pump produces the flow rate required to maintain the pressure (full cut-off). As shown in the graph of full cut-off power, the pressure is controlled with low input power. In the full cut-off state, the drain increases to more than that during the maximum output flow; drain piping should be carefully selected. The A series pumps are considerably quiet and energy-saving, and they are suitable for operation patterns where pressure holding is frequently required.

Tables 2.4 and 2.5 explain features, characteristics, and graphic symbols of various control types, including those that provide multistage flow and pressure control and those that maintain the output at a constant level. Electro-hydraulic pressure and flow control type with proportional solenoid control valves and pressure/swash plate angle sensors, and also electro-hydraulic load sensing type are available. This type offers high efficiency, ease in adjusting the output, and quick response through the use of mechatronic pumps, which are a harmonization of mechanics and electronics. Such pumps are energy-saving and suited for complicated hydraulic systems involving continuous flow and pressure control in multiple processes. These pumps are supplied as the “A series” and the “A3H series.” Generally, output of the variable displacement piston pumps can be manually adjusted with an adjustment screw.

**Table 2.3 Specifications of A and A3H Series**

Model Numbers	Displacement cm <sup>3</sup> /rev (cu.in./rev)	Max. Press. MPa (psi)	Max. Speed r/min
A10	10.0 (.610)	21 (3 046)	1 800
A16	15.8 (.964)	21 (3 046)	1 800
A22	22.2 (1.35)	16 (2 321)	1 800
A37	36.9 (2.25)	21 (3 046)	1 800
A56	56.2 (3.43)	21 (3 046)	1 800
A70	70.0 (4.27)	28 (4 061)	1 800
A90	91.0 (5.55)	28 (4 061)	1 800
A145	145.0 (8.85)	28 (4 061)	1 800
A3H16	16.3 (.995)	35 (5 076)	3 600
A3H37	37.1 (2.26)	35 (5 076)	2 700
A3H56	56.3 (3.44)	35 (5 076)	2 500
A3H71	70.7 (4.31)	35 (5 076)	2 300
A3H100	100.5 (6.13)	35 (5 076)	2 100
A3H145	145.2 (8.86)	35 (5 076)	1 800
A3H180	180.7 (11.0)	35 (5 076)	1 800

**■ Performance Characteristic Curve**

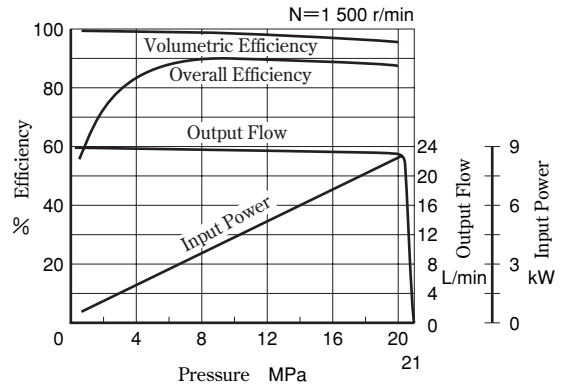

**■ Input Power**

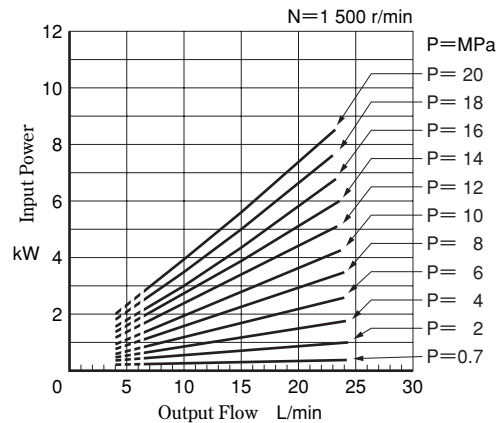

**■ Full Cut-off Power**

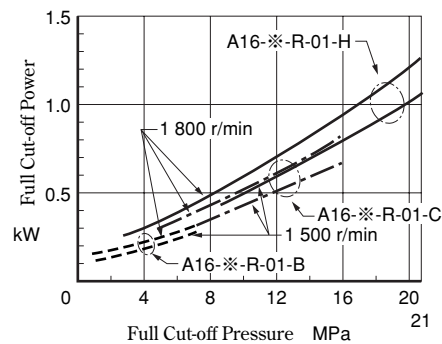

**■ Noise Level**

[One Meter Horizontally away from Pump Head Cover]

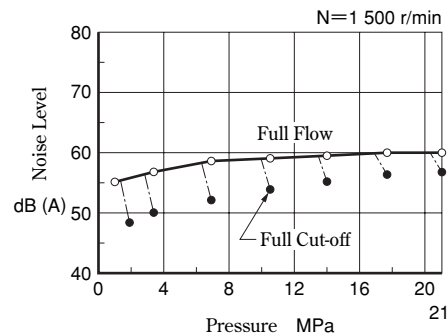

**Fig. 2.4 Typical Pump Characteristics**  
(Viscosity 20 mm<sup>2</sup>/s)

In a system using the variable displacement pump, a pressure surge is caused within the output line when a rapid shutoff of the output line with a solenoid operated valve or the stroke end of a cylinder changes the operation to the full cut-off from the maximum flow. In contrast, a pressure undershoot is caused by abruptly opening the line. These pressure variations and response times depend on the piping conditions (material (steel pipe or rubber hose), capacity, etc.). Figure 2.5 shows the response characteristics of the A series pumps.

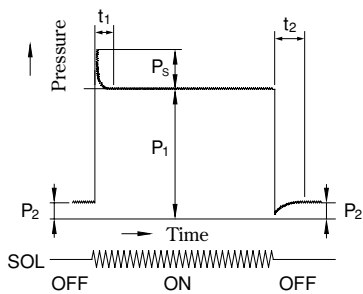

Model	Full Cut-off Pressure P <sub>1</sub> MPa	Pressure at Full Flow P <sub>2</sub> MPa	Response Time ms		Overshoot Pressure P <sub>s</sub> MPa
			t <sub>1</sub>	t <sub>2</sub>	
A10	21	2	100	75	2.6
A16	16	2	38*	59*	3.6
A22	16	2	30*	72*	5.9
A37	16	2	40*	78*	7.8
A56	16	2	38*	88*	7.6
A70	25	2	80	100	7.8
A90	25	3	90	110	7.9
A145	25	3	100	150	8.8

★The response time of A16 to A56 indicates displacement of the swash plates.

Fig. 2.5 Response Characteristics of Variable Pumps (Measurement Result)

Figure 2.6 compares electric power consumption by hydraulic injection-molding machines using a fixed displacement pump and a variable displacement pump, respectively. The fixed displacement pump PV2R is used with proportional pressure and flow control valves (proportional electro-hydraulic flow control and relief valves EFBG and ELFBG). The variable displacement pump is used with an A-series proportional electro-hydraulic load sensing type, which can keep the flow rate and pressure at the optimum level according to load. EFBG and ELFBG are energy-saving; they bleed excess flow from the pump according to load and maintain the pressure slightly higher than the load pressure. The comparison result, however, indicates that the variable displacement pump is still more energy-saving than the other.

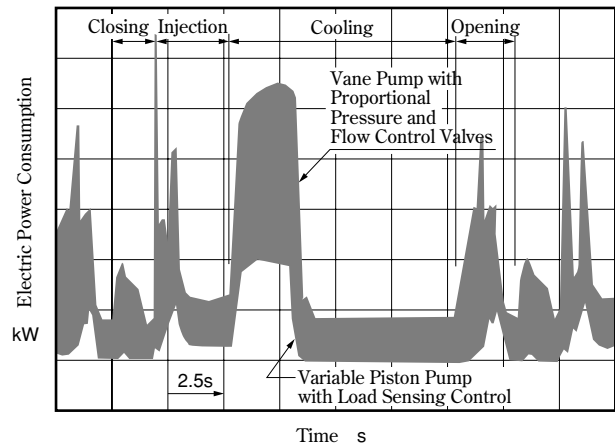

Fig. 2.6 Electric Power Consumption

### 2-2-2 Radial Piston Pumps

These pumps have pistons installed in a pattern radial to the pump rotating shaft. The pumps are more suitable for high pressure operation than the axial type.

Figure 2.7 shows the structure of a typical radial piston pump. Piston stroke is achieved with an eccentricity of the piston-sliding ring to the pump rotating shaft. These pumps switch suction and discharge per piston stroke in the ring. With a mechanism for ring eccentricity change added, the pumps allow their displacement to be adjusted.

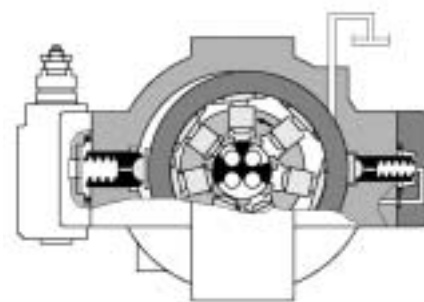

Fig. 2.7 Radial Piston Pump

Table 2.4 “A” Series Piston Pump Control Type

Control Type	Graphic Symbols	Performance Characteristics	Description
“01” Pressure Compensator Type			<ul style="list-style-type: none"> <li>When the system pressure increases and approaches the preset full cut-off pressure, the pump flow decreases automatically while the set pressure is maintained.</li> <li>The output flow and full cut-off pressure can be manually adjusted.</li> </ul>
“02” Solenoid-two Pressure Control Type			<ul style="list-style-type: none"> <li>Two levels of the full cut-off pressures (high and low) can be set by turning on/off the solenoid.</li> <li>This type of control is ideal for an application where the output power of the actuator must be controlled in two different load pressures while keeping the actuator speed nearly constant.</li> <li>The pump can be used in combination with a multistage pressure control valve.</li> </ul>
“03” Pressure Compensator with Unloading Type			<ul style="list-style-type: none"> <li>This type of control is based on the pressure compensator type with the unloading function added.</li> <li>It is suitable for a situation where a long unloading time is required.</li> <li>Heat generation and noise have to be kept at their lowest levels.</li> <li>The pump can be used in combination with the multistage pressure control valve.</li> </ul>
“04” Proportional Electro-Hydraulic Load Sensing Type			<ul style="list-style-type: none"> <li>This is an energy-saving type control which regulates the pump flow and load pressure to be at the absolute minimum necessary level to operate the actuator.</li> <li>Input current is regulated by a specific amplifier.</li> <li>Pump flow rate and cut-off pressure are controlled proportional to the input current to the control device on the pump.</li> </ul>
“04E” Proportional Electro-Hydraulic Pressure & Flow Control Type			<ul style="list-style-type: none"> <li>This type of control has the pressure sensor and tilt angle sensor in the pump. The pump is used with the external amplifier. Flow and pressure can be controlled in proportion to input voltage by only one control valve.</li> <li>The characteristics are greatly improved by electrical feedback of the swash plate tilt angle corresponding to flow rate and load pressure to the control valve.</li> <li>Linearity of input-output characteristics (input voltage-pressure and input voltage-flow rate) is excellent and easy to set.</li> <li>Hysteresis is lower, and repeatability and reproducibility are fine.</li> </ul>
“05” Two-Pressure Two-Flow Control Type by System Press.			<ul style="list-style-type: none"> <li>This type of control enables one pump to act as two pumps (low-pressure and large-flow/high-pressure and small-flow). Therefore, the motor capacity can be reduced.</li> <li>When the system pressure increases near the preset “PL” pressure due to a load increase, the pump flow automatically decreases to “QL”.</li> <li>This type of control is suitable for an application like the press, where switching from rapid advance to feed is required just when the press (pressurizing) starts.</li> </ul>
“06” Two-Pressure Two-Flow Control Type by Solenoid Valve			<ul style="list-style-type: none"> <li>This type of control can enable one pump to act as two pumps (low-pressure and large-flow/high-pressure and small-flow). Therefore, the motor capacity can be reduced.</li> <li>This type of control can switch two levels of the flow rate and pressure (low-pressure and large-flow/high-pressure and small-flow) by turning on/off the solenoid.</li> <li>This pump control is suitable for machine tools, where machining starts after switching from rapid advance to feed.</li> </ul>



Table 2.4 “A” Series Piston Pump Control Type (Continued)

Control Type	Graphic Symbols	Performance Characteristics	Description
<p>“07” Pilot Pressure Control Type Pressure Compensator</p>			<ul style="list-style-type: none"> <li>● The pump is used in combination with a remote control relief valve or multistage pressure control valve.</li> <li>● By controlling the pilot pressure, the full cut-off pressure can be remote-controlled according to user requirements.</li> </ul>
<p>“09” Constant Power Control Type</p>			<ul style="list-style-type: none"> <li>● Pump input power can be controlled in accordance with the motor output.</li> <li>● When the discharge pressure rises, the output flow decreases corresponding to the preset input power.</li> <li>● The pump can act as two pumps (low-pressure and large-flow/high-pressure and small-flow). Therefore, the motor capacity can be reduced.</li> </ul>
<p>“00-Z500” Simple Two-Pressure Two-Flow Control Type</p>			<ul style="list-style-type: none"> <li>● This type of control enables one pump to act as two pumps (low-pressure and large-flow/high-pressure and small-flow-rate). Therefore, the motor capacity can be reduced.</li> <li>● When the system pressure increases near the preset “PL” pressure due to the load increase, the pump flow automatically decreases to “QL.”</li> <li>● This type of control is suitable for an application like the press, where switching from rapid advance to feed is required just when the press (pressurizing) starts.</li> <li>● The PH pressure can be remote-controlled with a separately located relief valve. With this type of control, it is easy to change the applied pressure setting when materials or shapes of the press are changed.</li> </ul>

Table 2.5 “A3H” Series Piston Pump Control Type

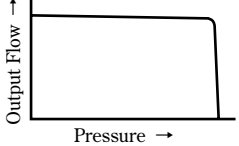
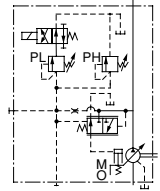
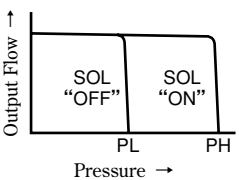
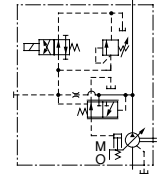
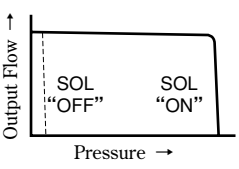
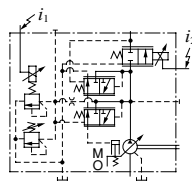
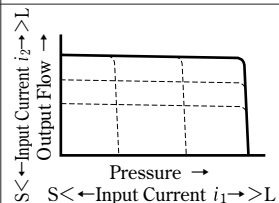
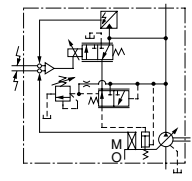
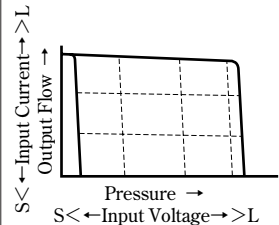
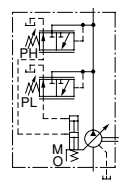
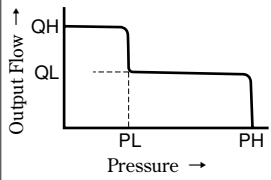
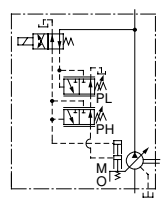
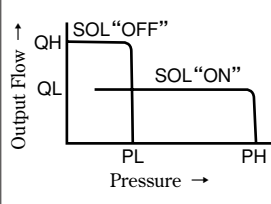
Control Type	Graphic Symbols	Performance Characteristics	Description
<p>“01” Pressure Compensator Type</p>			<ul style="list-style-type: none"> <li>● When the system pressure increases and approaches the preset full cut-off pressure, the pump flow decreases automatically while the set pressure is maintained.</li> <li>● The output flow and full cut-off pressure can be manually adjusted.</li> </ul>
<p>“09” Constant Power Control Type</p>			<ul style="list-style-type: none"> <li>● It can control the pump input power according to the motor output.</li> <li>● When the system pressure increases and approaches the preset input power, the pump swash plate tilt angle (output flow) decreases.</li> <li>● This type of control can enable one pump to act as two pumps (low-pressure and large-flow/high-pressure and small-flow). Therefore, the motor capacity can be reduced.</li> </ul>
<p>“14” Load Sensing Control Type</p>			<ul style="list-style-type: none"> <li>● This is an energy-saving type control which regulates the pump flow and load pressure to be at the absolute minimum necessary level to operate the actuator.</li> <li>● This type of control automatically regulates the output flow so that the inlet-outlet differential pressure of the flow control valve at the output side is constant. To do so, the load pressure must be introduced to the load sensing port “L” of the pump through the external piping.</li> <li>● This type of control can actualize the remote control of the full cut-off pressure by connecting a remote control relief valve to the pilot port “PP.”</li> </ul>

## 2-3 Vane Pumps

These pumps intake and discharge fluid according to the change of space enclosed by the vanes and the cam ring that rotates by means of the rotor. Vane pumps in a low/middle pressure range from approximately 7 to 25 MPa (1 015 to 3 626 psi) and with middle displacement; for example, the single middle-pressure type has a displacement of approximately 300 cm<sup>3</sup>/rev (18.3 cu.in./rev). These pumps provide the following advantages: (1) minimized discharge pressure pulsation; (2) compactness and light weight for high output; (3) less efficiency degradation due to vane wear, and; (4) reliability and ease of maintenance.

The pumps are quieter because of the structure and are less susceptible to working fluid contamination than piston pumps. Therefore, they are conveniently used in a wide range of applications. The pumps typically have a structure where the vane is pressed against the cam ring by inducing pressurized flow to the bottom of the vane. With the improved structure, pumps capable of operating at a high pressure of up to 42 MPa (6 092 psi) are also commercially available.

Vane pumps are categorized into fixed and variable displacement types. Each type is further subcategorized into single and multiple pumps. With vane pumps, it is easy to construct double and triple pumps by mounting pump elements (components such as rotors, vanes, and cam rings) in tandem to the pump shaft. Such multiple pumps with displacements of 300 to 500 cm<sup>3</sup>/rev (18.3 to 30.5 cu.in./rev) have been commercialized.

Variable displacement type vane pumps, with changing ring eccentricity, are also available. These pumps, with displacements of 30 cm<sup>3</sup>/rev (1.83 cu.in./rev) or less, are widely used as hydraulic pressure sources for small machine tools.

### 2-3-1 Single Vane Pumps

#### (1) Low Pressure Vane Pumps

These low pressure vane pumps, operated at 5 to 7 MPa (725 to 1 015 psi), are supplied as the PVL1, 50T, 150T, 250F, and 500F series. The pumps are available in the displacement of 1.5 to 498 cm<sup>3</sup>/rev (.092 to 30.4 cu.in./rev). They have a simple structure: clearances between the rotor and the vane side are maintained with a fixed plate. The inner space of the cam ring is structured with an oval circle and complete round circle. The curved and connected space between the circles is where the vanes make the elevation movement. The pumps have two pairs of suction and discharge areas and balance the internal radial force with the discharge pressure; thus, these pumps are called the pressure balanced type (Table 2.1).

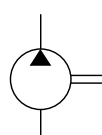
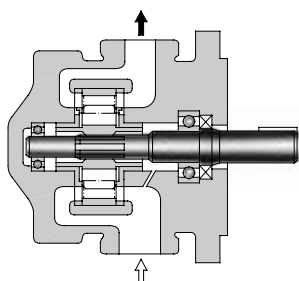

Graphic Symbol

Fig. 2.8 Low Pressure Vane Pump

#### (2) Middle Pressure Vane Pumps

These pumps operate at 16 to 21 MPa (2 321 to 3 046 psi). The PV2R series, specially designed to reduce the noise level, are available in four sizes, ranging from 6 to 237 cm<sup>3</sup>/rev (.366 to 14.46 cu.in./rev). The pumps have a plate with a pressure loading, which changes the clearance between the rotor and the vane side according to the pressure. Figures 2.9 and 2.10 show a PV2R series pump and its typical characteristics.

The simplest vane lift mechanism is the straight type; it introduces the discharge pressure to the base to counterbalance the discharge pressure applied to the bottom of the vane. Other mechanisms, such as the intra vane type where small vanes are embedded into the vanes and the pin type where vanes are pushed with pins, as shown in Fig. 2.11, are available.

These two types have better mechanical efficiency than the straight type because they need less force to lift the vanes from the base. The pin type pumps operating at 25 to 28 MPa (3 626 to 4 061 psi) have been commercially supplied.

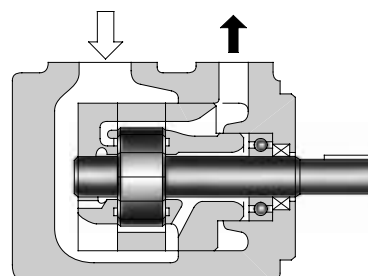
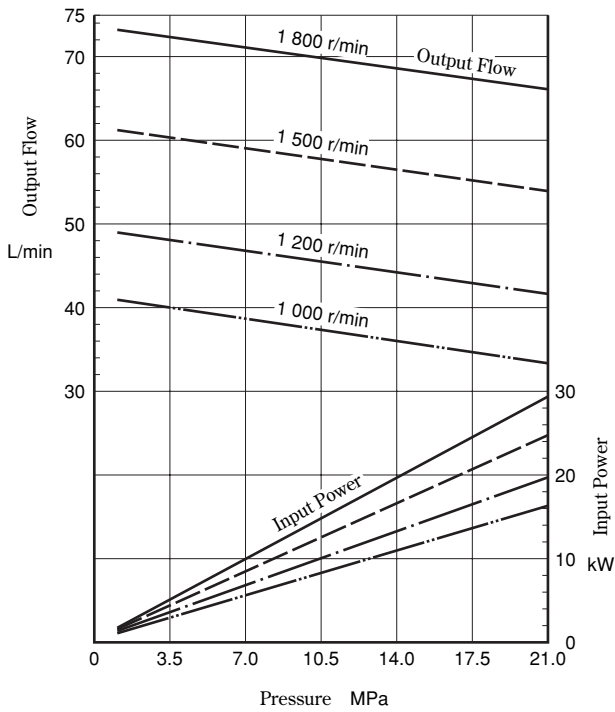

Fig. 2.9 Middle Pressure Vane Pump

● PV2R2-41

Pressure-Output Flow and Input Power Characteristics



● PV2R2-41

Noise Level

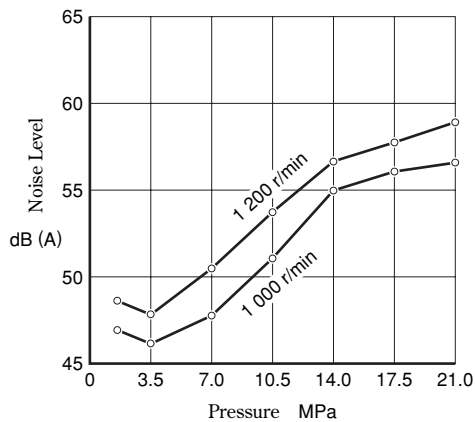
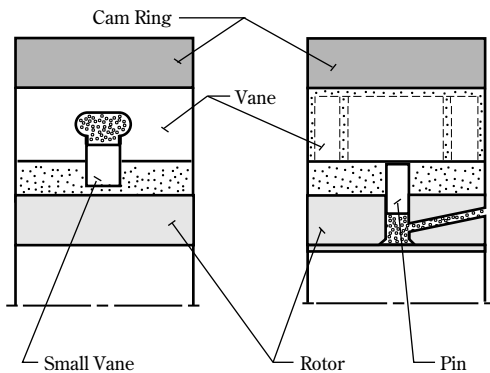

Fig. 2.10 Typical Characteristics of the PV2R2 Pump



● Intra Vane Type

● Pin type

Fig. 2.11 Vane Lift Mechanism

(3) High Pressure Vane Pumps

These pumps operate at 31.5 to 40 MPa (4 569 to 5 802 psi). The PV11R series pumps are available in two sizes, ranging from 2 to 22 cm<sup>3</sup>/rev (.122 to 1.34 cu.in./rev). Some of them have the pressure loading mechanism, while the others are provided with a unique valve structure that decreases and introduces the pressure to the vane base to reduce the sliding friction between the vane and the cam ring. Those with the unique valve structure are used in high-pressure press machines, etc.

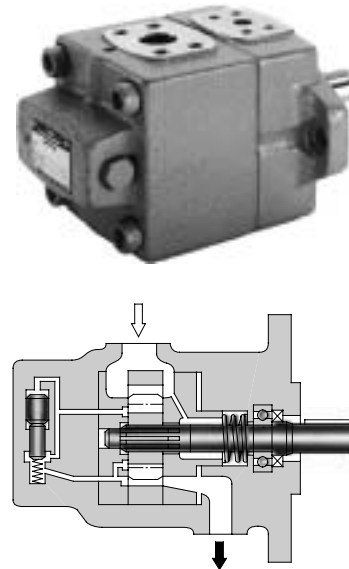

Fig. 2.12 High Pressure Vane Pump

● PV11R10-12

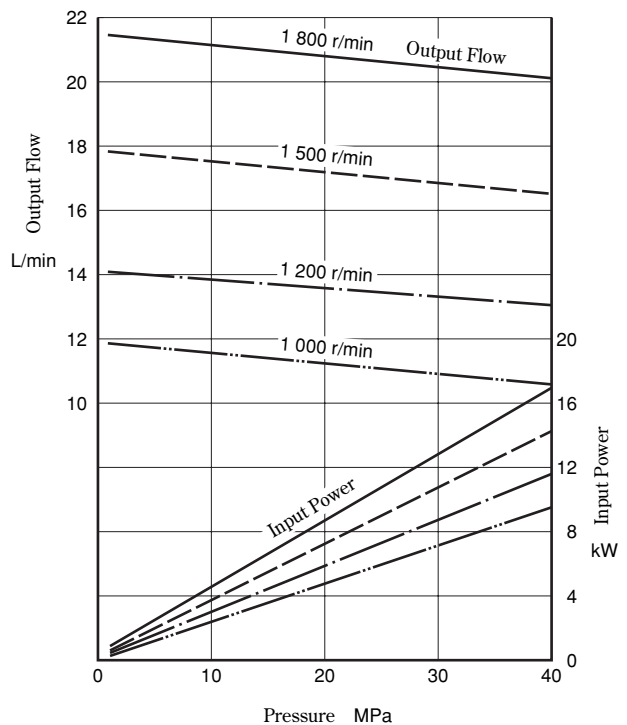
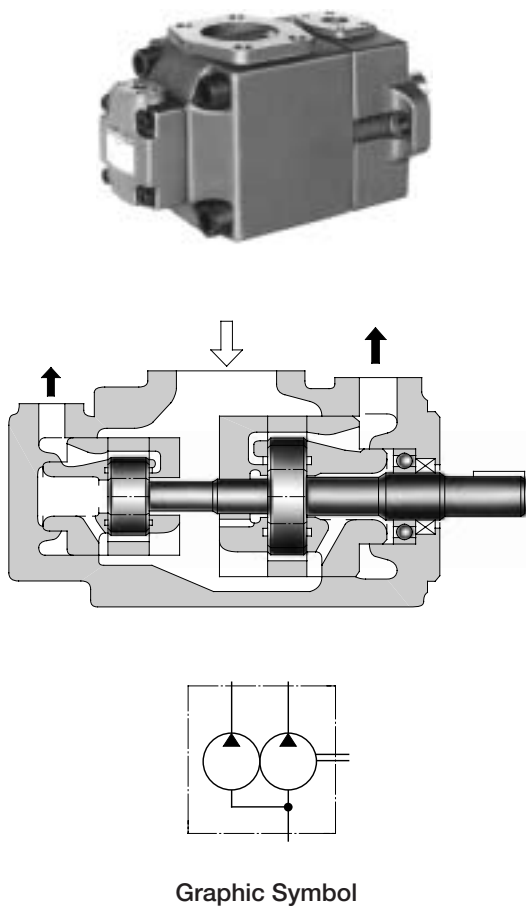

Fig. 2.13 Pressure-Output Flow and Input Power Characteristics of the PV11R10 Series Pump



### 2-3-2 Multiple Vane Pumps

These pumps are categorized into double and triple types. The double pump has two sets of cartridge kits on one shaft, and each of the kit works independently. Generally, this type contains a combination of low-pressure large-volume and high-pressure low-volume pump elements. The triple pump has three sets of cartridge kits and forms a circuit to sum up the output pressures for applications requiring a larger displacement. Figure 2.14 shows a PV2R series double pump. Figure 2.15 shows circuit examples of low-pressure/large-volume and high-pressure/small-volume combinations for press machines.



Graphic Symbol

Fig. 2.14 PV2R Series Double Vane Pump

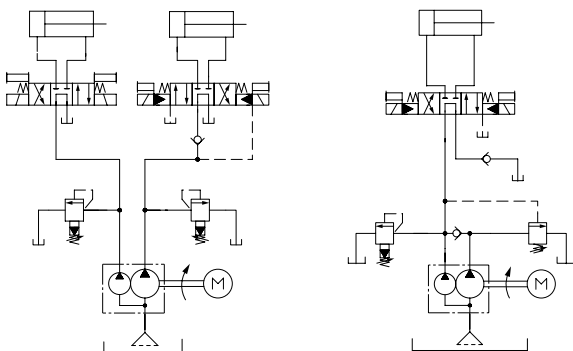

Fig. 2.15 Application Examples of the Double Pump

### 2-3-3 Variable Displacement Vane Pumps

Vane pumps can be transformed to the unbalanced type by making the center of the round cam ring eccentric to the rotating shaft; this type provides a pair of suction and discharge processes. The pumps can also be transformed to the variable displacement type by making the cam ring at the maximum eccentricity concentric with the shaft (the output flow continuously reduces to zero). The variable displacement type is not pressure balanced and has a greater force in the radial direction than the fixed displacement type.

Figure 2.16 shows the appearance and cross sectional view of a typical small-sized variable displacement vane pump. It is a pressure compensator type with a mechanism that uses a spring to make the cam ring eccentric to the maximum level at a low pressure. However, when the pressure reaches a preset level, the hydraulic power exceeds the spring force to reduce the eccentricity.

The variable displacement vane pumps that offer displacements of 8 to 22 cm<sup>3</sup>/rev (488 to 1.34 cu.in./rev) and operate at 7 MPa (1 015 psi) or less are widely used in small machine tools because of inexpensiveness and low noise level. Those that offer a displacement of 160 cm<sup>3</sup>/rev (9.76 cu.in./rev) and operate at 16 MPa (2 321 psi) or less are also available.

Similar to the piston pumps, large-volume variable displacement pumps with load sensing control are commercially supplied; however, the variable displacement pumps are generally used in low/middle pressure ranges.

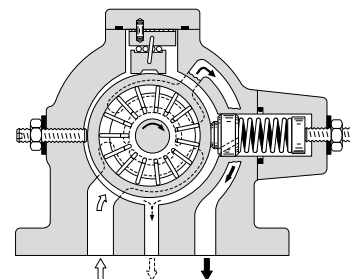

Fig. 2.16 Small-sized Variable Displacement Pump

## 2-4 Gear Pumps

These pumps operate with two gears engaged with each other and rotating to feed a hydraulic fluid from the suction area to the discharge area. They all have fixed (constant) displacement capacities. They are categorized into external and internal gear pumps; the internal type generally has smaller discharge pulsation and lower noise level than the other. The gear pumps are relatively resistant to working fluid contamination. Pumps operate at 20 to 25 MPa (2 901 to 3 626 psi) and offer a displacement of 100 cm<sup>3</sup>/rev (6.10 cu.in./rev) for the single type. Similar to vane pumps, double type gear pumps are easy to construct.

High pressure gear pumps often adopt involute gears, which allow highly accurate processing, bringing about high system operation efficiency. Contacting with each other at two points, the gears rotate to entrap oil in the engaging parts, resulting in vibration and noise, which are reduced by a groove on the side plate allowing the oil to escape. Some low pressure gear pumps use trochoid gears. Figures 2.17 and 2.18 show the external and internal gear pumps.

The displacement of external gear pumps is determined by a chamber between the neighboring gear teeth and the inner surface of the casing; the displacement of the internal gear pump is determined by a chamber between the external and internal gears and a dash board. The crescent-shaped dash board (filler piece) separates the suction and discharge areas. For both the types, the sides of the gear teeth are sealed with side plates. The high pressure external gear pumps have a movable side plate by which high pressure flow is led to the rear side to press against the gear and keep a suitable clearance.

Gear pumps consist of relatively simple parts. They offer high suction performance at a low cost and are used in various fields: forklifts, industrial platform vehicles, construction machines such as excavators and wheel loaders, and supporting pumps for primary pumps. Compact packages containing the gear pump, safety and check valves, oil reservoir, and DC motor are popular in automobiles.

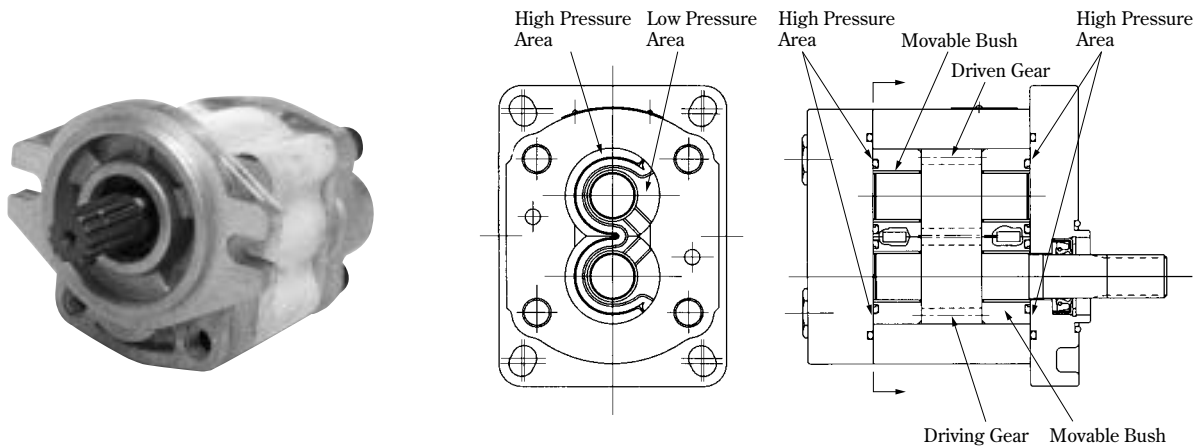

Fig. 2.17 External Gear Pump

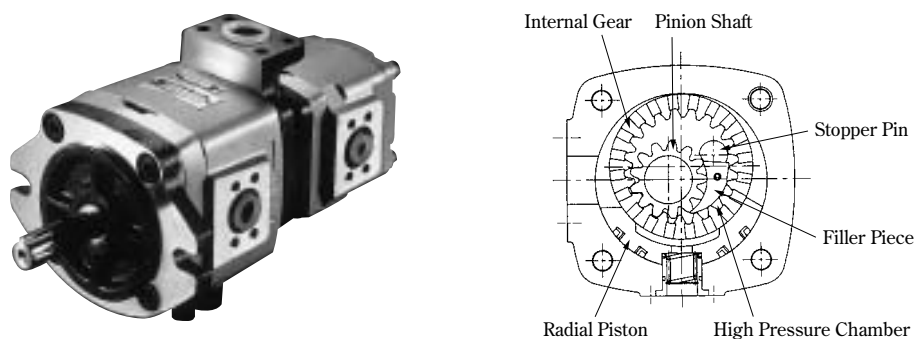

Fig. 2.18 Internal Gear Pump

## 2-5 Screw Pumps

These pumps operate by rotating two or three screw shafts, which are aligned and engaged in parallel, to continuously convey a volume structured with screw leads. Unlike the other types of pumps, they have no intermittent displacement variation and abrupt pressure variation. Because of the low noise level and reduced pulsation, they are used as hydraulic pressure sources for hydraulic lifts and submarines. Because gear pumps are less susceptible to working fluid contamination, they are also used for pumping cutting oils and lubricants.

Figure 2.19 shows an example of the triple-screw type, which can operate with up to 25 MPa (3 626 psi) at 3 600 r/min or less. The pumps are available in displacements of 700 L/min (185 U.S.GPM) or less for high pressure operation and 1 800 L/min (476 U.S.GPM) or less for low pressure operation.

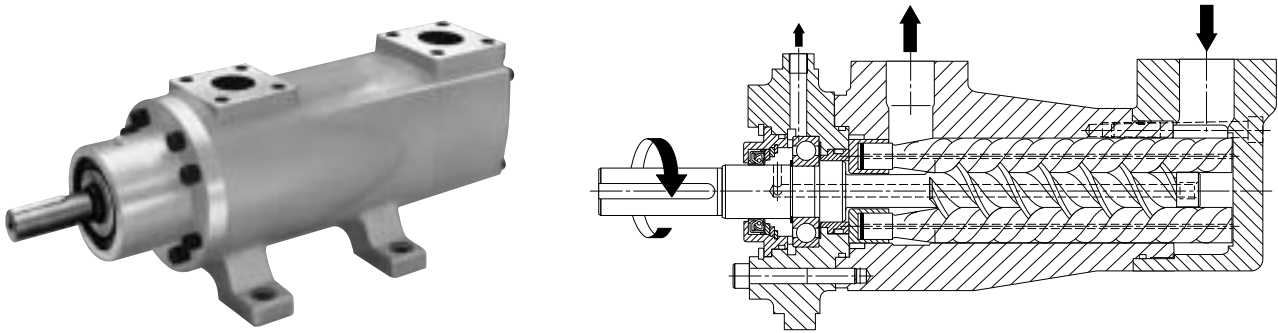

Fig. 2.19 Screw Pump

## 2-6 Reciprocal Pumps

These pumps have pistons installed at right angles against the pump rotating shaft in a plane including the shaft. The pistons reciprocate with alternately moving cranks or eccentric cams. Pumps suffer from discharge pulsation because they have a fewer pistons than the axial and radial types; however, they can operate at a high pressure of up to 100 MPa (14 504 psi). These pumps are used for high-pressure applications such as construction vehicles, cargo-loading machines, and press machines. In addition, they can handle water or water-containing fluids as the working fluid because of the construction to be wider area applicable for lubrication.

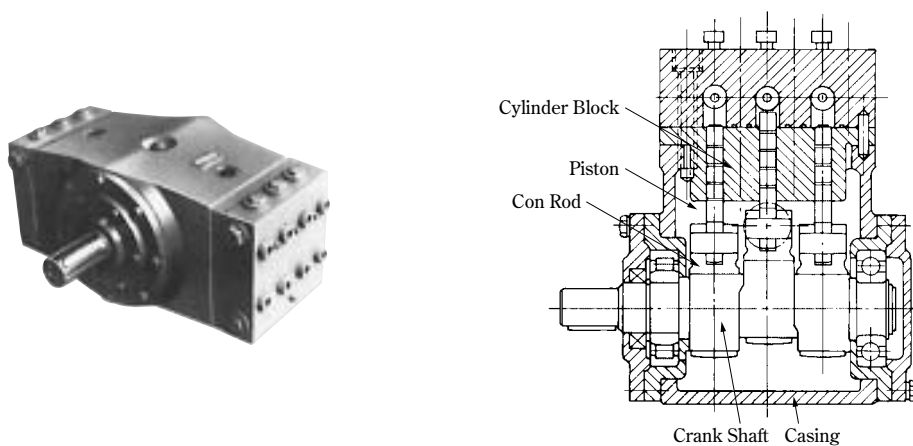

Fig. 2.20 Reciprocal Piston Pump

# 3

## PRESSURE CONTROL VALVES

Valves control pressure in a hydraulic circuit and are grouped as below according to the control to be achieved in each circuit.

- 3-1 Relief Valves
- 3-2 Sequence Valves
- 3-3 Counterbalance Valves
- 3-4 Unloading Relief Valves
- 3-5 Pressure Reducing Valves/Pressure Reducing and Check Valves
- 3-6 Brake Valves
- 3-7 Balancing Valves (Pressure Reducing and Relieving Valves)
- 3-8 Pressure Switches

### 3-1 Relief Valves

These relief valves protect pumps and other control valves from excessive pressure in hydraulic systems and maintain a constant system pressure. The variations are the direct, pilot operated, and solenoid controlled types.

#### 3-1-1 Direct Type Relief Valves

These valves are small and have a simple structure for their capacity. However, they are likely to exhibit high-pressure override (a pressure characteristic observed when a fluid starts flowing from a valve and reaches the rated flow rate) and chattering. Therefore, they are used to control the pressure of relatively small flows, as shown in Fig. 3.2. Valves of the size 1/8, in particular, are very popular for pilot pressure controls.

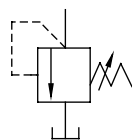
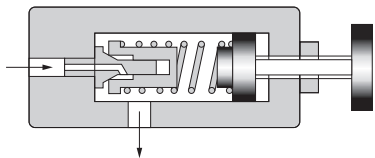

Graphic Symbol

Fig. 3.1 Direct Type Relief Valve

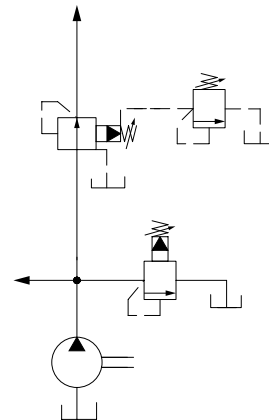

Remote Control of Pressure Reducing Valve by Relief Valve

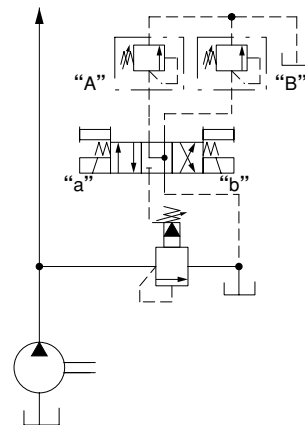

Three-Pressure Control by Relief Valve

Fig. 3.2 Examples

### 3-1-2 Pilot Operated Relief Valves

These valves consist of a balanced piston for bypassing excess flow in hydraulic circuits and a pilot that controls the piston motion and pressure. Placed in a vent circuit, they can perform remote control, unloading, or two-

pressure control.

Specifications of the pilot operated relief valves (Fig. 3.3) are shown in Table 3.1. In addition, low noise and high pressure types (35 MPa (5 076 psi) Max.) are also available.

**Table 3.1 Specifications**

Model Numbers		Max. Working Pressure MPa (psi)	Press. Adj. Range MPa (psi)	Max. Flow L/min (U.S.GPM)	Approx. Mass kg (lbs.)	
Threaded Connections	Sub-plate Mounting				BT type	BG type
BT-03-※-32	BG-03-※-32	25 (3 626)	★~25 (★~3 626)	100 (26.4)	5.0 (11.0)	4.7 (10.3)
BT-06-※-32	BG-06-※-32			200 (52.8)	5.0 (11.0)	5.6 (12.3)
BT-10-※-32	BG-10-※-32			400 (106)	8.5 (18.7)	8.7 (19.2)

★ Refer to the Minimum Adjustment Pressure Characteristics.

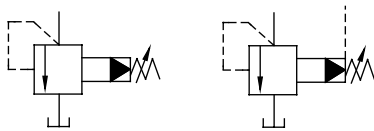
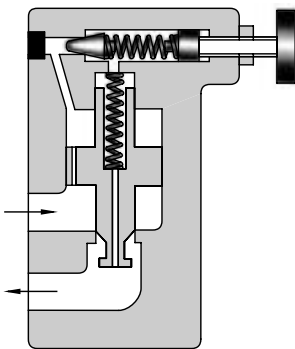

Vent Connection

Graphic Symbol

**Fig. 3.3 Pilot Operated Relief Valve**

Figure 3.4 shows characteristics of flow vs. pressure (pressure override) of the relief valve, 3/4-size. Figure 3.5 shows characteristics of flow vs. vent pressure and the minimum adjustment pressure. A vent pressure is a relief pressure released upon opening a vent. When the flow exceeds a certain level, the vent pressure

rapidly increases with flow resistance. The minimum adjustment pressure refers to a relief pressure obtained when the control pressure of the pilot valve is set to the lowest level.

When a relief valve is loaded with a circuit as depicted in Fig. 3.6, the transient pressure characteristics appear as shown in Fig. 3.7.

t represents a delay time of the relief valve and T, that of the system. The smaller the pipe capacity and the lower the pipe pressure, the shorter the delays t and T. To evaluate the delays of the entire system, both t and T must be taken into account.

Hydraulic Fluid : Viscosity 35 mm<sup>2</sup>/s  
Specific Gravity 0.850

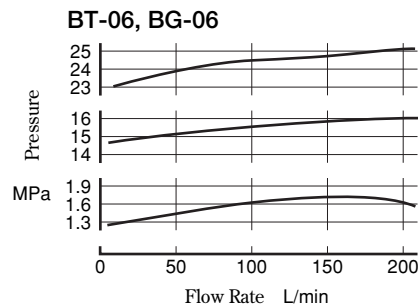

**Fig. 3.4 Nominal Override Characteristics**

Hydraulic Fluid : Viscosity 35 mm<sup>2</sup>/s  
Specific Gravity 0.850

— Vent Pressure  
- - - Min. Adjustment Pressure

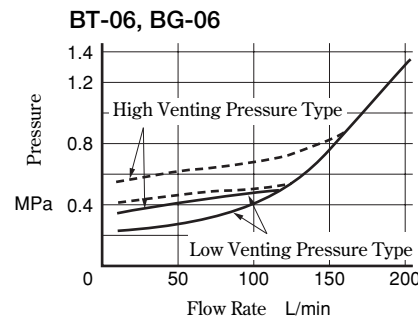

**Fig. 3.5 Min. Adj. Pressure & Vent Pressure vs. Flow**

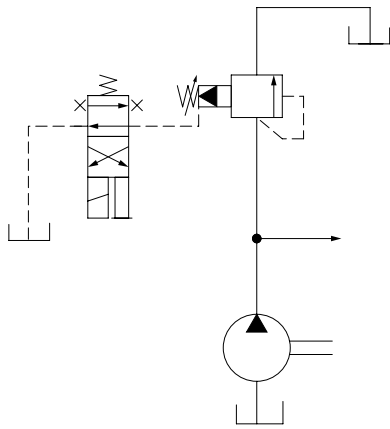

Fig. 3.6 Example

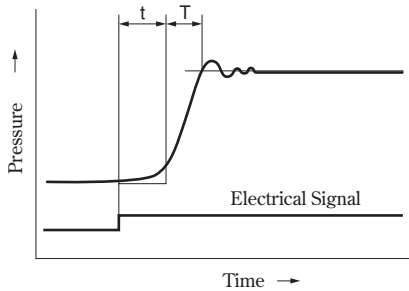
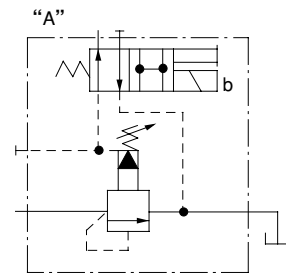
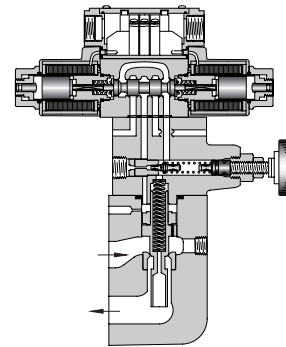

Fig. 3.7 Transient Pressure Characteristics

### 3-1-3 Solenoid Controlled Relief Valves

These valves are a combination of a pilot operated relief valve and a small solenoid operated directional valve. Sending electrical signals to the directional valve can remotely unload pump pressure or conduct the two- or three-pressure control in hydraulic circuits. For adjusting pressure in the two- or three-pressure control, use one or two direct type relief valves.



Graphic Symbol

Fig. 3.8 Solenoid Controlled Relief Valve

## 3-2 Sequence Valves

These valves control the sequential operation of two or more actuators. If the inlet pressure exceeds a preset level, they deliver effective pressure to the outlet side. The valves can serve as pressure holding valves to maintain hydraulic pressure in a circuit. When a sequence valve is installed between a directional control valve and a cylinder, it needs reversed free flow; therefore, the valve should contain a check valve. The sequence valves and counterbalance valves, described in the next section, are generally known as H/HC type pressure control valves, and how they are assembled determines the nature of the combined valve, either H or HC type.

Note that a sequence valve with an auxiliary pilot port can provide two-pressure control (high/low) by delivering the pilot pressure of the auxiliary pilot port to the pilot piston. Pressure required for this auxiliary remote control is approximately 1/8 of the adjustment pressure (approximately 1/16 when the adjustment pressure is 7 MPa (1 015 psi) or more). The example is shown in Fig. 3.10.

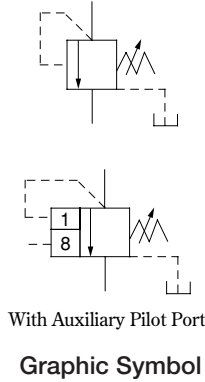
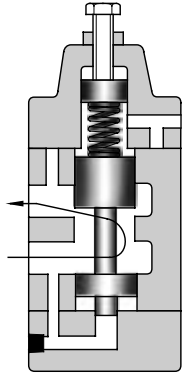
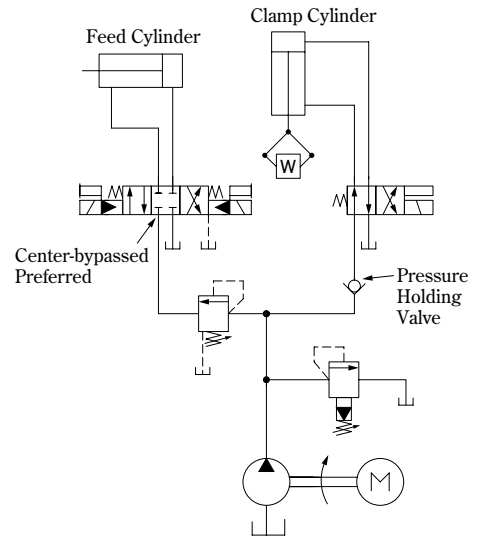

Fig. 3.9 Sequence Valve



Use as Pressure Holding Valve

Fig. 3.10 Example

### 3-3 Counterbalance Valves

These valves maintain hydraulic pressure in a hydraulic system or load backpressure on a cylinder. If the inlet pressure exceeds a preset level, flow is released to keep the pressure constant. They are accompanied with a check valve that allows the flow for lifting a cylinder up to freely pass. To control the cylinder speed, those with meter-in control (see P. 33) are generally used for both upward and downward movement of the cylinder. Similar to the sequence valves, some counterbalance valves are equipped with an auxiliary pilot port.

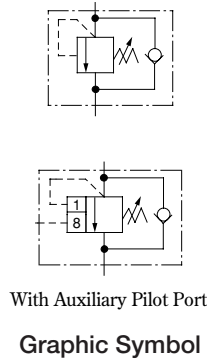
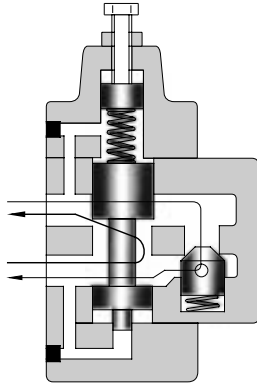

Fig. 3.11 Counterbalance Valve

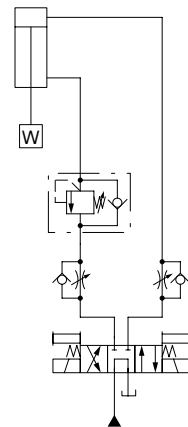
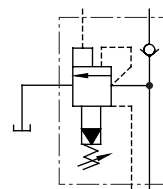
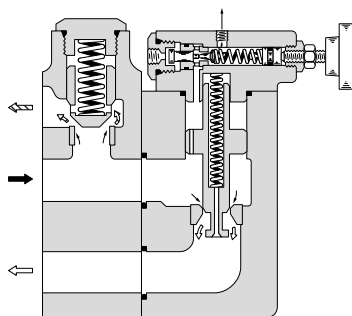

Fig. 3.12 Example



### 3-4 Unloading Relief Valves

These valves are used to operate pumps at the minimum load in an accumulator circuit or in a high-low pump circuit. In an accumulator circuit, when the system pressure reaches a preset level (i.e. cut-out pressure), the valve opens to divert the pump delivery to the reservoir at low pressure; thus, the pump is unloaded automatically. When the system pressure drops to the cut-in pressure (approximately 85% of the cut-out pressure normally), the valve closes to direct the loaded pump delivery to the accumulator and the hydraulic system.



Graphic Symbol

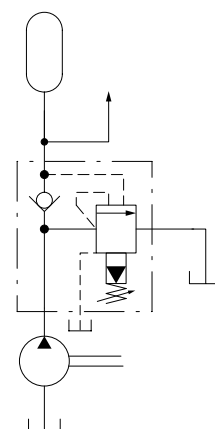
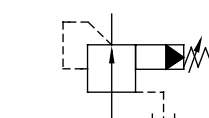
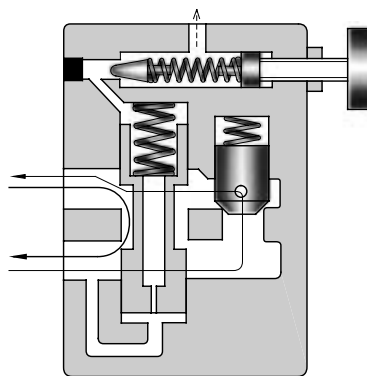

Fig. 3.13 Unloading Relief Valve

Fig. 3.14 Example

### 3-5 Pressure Reducing Valves/Pressure Reducing and Check Valves

These valves set hydraulic circuit pressure equal to or below a pressure in the main circuit. When the outlet pressure reaches a preset level, the valve opens, and the balanced piston moves to throttle a passage to keep the outlet pressure constant; thus, the pressure is reduced. The outlet pressure is maintained constant, regardless of the inlet pressure. If flow resistance at the inlet side is equal to or lower than the preset pressure for the pressure reducing valve, the outlet pressure is given at the same level as the inlet pressures. If flow resistance at the outlet side is equal to or lower than the preset pressure for the valve, the valve opens fully; therefore, both the inlet and outlet pressures are the same.



Pressure Reducing Valve

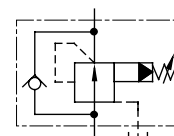

Pressure Reducing and Check Valve

Graphic Symbol

Fig. 3.15 Pressure Reducing and Check Valve

### 3-6 Brake Valves

These valves smoothly stop actuators that have a large inertia force. When a directional control valve is closed, a relief valve at the outlet side releases the accumulating pressure while maintaining the circuit pressure at the preset level. At the inlet side, a check valve feeds the flow, supply of which has been blocked by the directional control valve, to reduce a risk of cavitation.



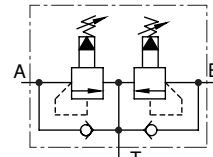
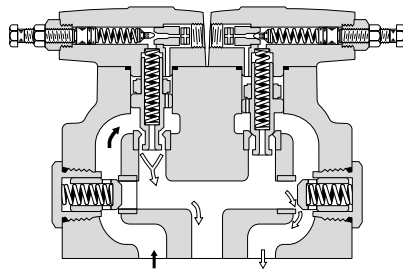

Graphic Symbol

Fig. 3.16 Brake Valve

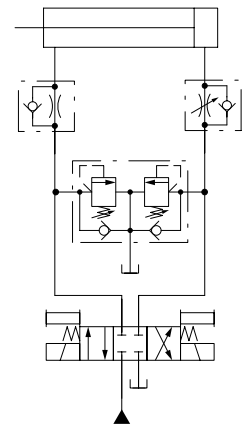
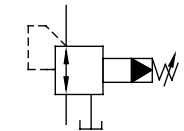
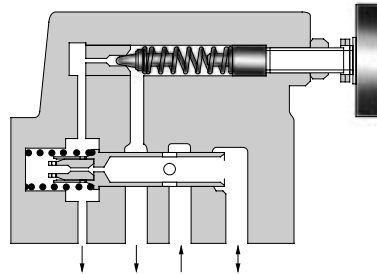

Fig. 3.17 Example

### 3.7 Balancing Valves (Pressure Reducing and Relieving Valves)

These valves are combination valves that have pressure reducing and counterbalancing functions developed for applications such as a hydraulic balance circuit in a vertical machining center. When the pressure reducing function is employed, the outlet pressure is maintained at the preset level for pressure reduction, regardless of the inlet pressure. If the counterbalancing function is employed, the outlet pressure is maintained at the preset level for pressure relief, which is higher than the pressure reducing.



Graphic Symbol

Fig. 3.18 Balancing Valve

### 3-8 Pressure Switches

Pressure switches are used in hydraulic systems to make or break an electrical circuit at a preset hydraulic pressure. A sensing component made of semi-conducting materials detects the pressure. The switches are used with relays to operate solenoid valves to unload pumps or start/stop motors.

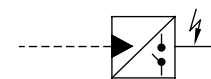
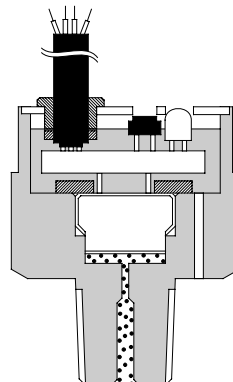

Graphic Symbol

Fig. 3.19 Pressure Switch

# 4

## DIRECTIONAL CONTROL VALVES

Directional control valves control start/stop, directions, and acceleration/deceleration of hydraulic cylinders and motors. They can be used in a various applications, and a wide range of products is available.

They can be categorized into three types: spool, poppet, and ball. The spool type can be either a sliding type or a rotary type. The former is the most popular for pressure balancing and high capacity.

The poppet type offers excellent leak-tight capability (zero leak) for its poppet-seat contact. The ball type is an alternative for the poppet; a ball is used instead of a poppet.

4-1 Classification of Directional Control Valves

4-2 Structure and Characteristics of Directional Control Valves





### 4-1 Classification of Directional Control Valves

#### 4-1-1 Classification by Port/Position Count

The port count indicates the number of connectable lines, and the position count indicates the number of changeovers in the directional control valves. Table 4.1 lists the classifications. The valves with four ports and three

positions are very popular. The four ports include: pump port (P), tank port (T), and cylinder ports (A and B). The symbols are often appended with graphic symbols of the directional control valves.

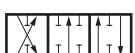
Table 4.1 Classification by Port/Position Count

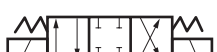
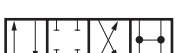
Classification		Graphic Symbol	Remarks
No. of Ports (Connections)	Two Ports		This valve has two ports to open/close a hydraulic line.
	Three Ports		This valve has three ports for changeover from the pump port to two ways only.
	Four Ports		This valve has four ports for a wide variety of purposes, including moving the actuator forward and backward or stopping it.
	Multiple Ports		This valve has five or more ports for special purposes.
No. of Positions	Two Positions		This valve has two positions.
	Three Positions		This valve has three positions.
	Multiple Positions		This valve has four or more positions for special purposes.

#### 4-1-2 Classification by Spool Types

The directional control valves in hydraulic systems must work such that when the spools are in a neutral position, the fluid flow patterns meet the purpose of the systems, in addition to causing reversible motion of the hydraulic cylinders and motors.

For example, take the “three-position” valve in Table 4-1. This closed-center valve (all ports are closed when the spool is in the neutral position) locks the cylinder at its

position. The pressure in the pump line is maintained at a preset level for the relief valve or the variable pumps, and other systems can be operated as desired. On the other hand, the center-bypassed valve (ports P and T are open when the spool is in the neutral position) unloads the pump line while locking the cylinder, which is desirable for energy saving: lower heat generation and reduced pump load.

However, the overall performance of the hydraulic system should be taken into consideration to choose the best valves for it. Table 4.2 lists common spool types with their

functions and usage. Note that the numbers in the double quotation marks “\*\*” may vary according to valve manufacturers.

Table 4.2 Spool Types





Spool Type	Graphic Symbol	Valve and Spool (Neutral Position)	Function and Usage
“2” Closed-Center			Maintains the pump pressure and cylinder position in the neutral position. For the two-position type, each port is blocked during the spool transition, causing shock to the system line. This type requires due caution.
“3” Open-Center			Unloads the pump and floats the actuators in the neutral position. For the two-position type, each port is connected to the tank during the spool transition; thus, shock can be reduced.
“4” ABT Connected			Maintains the pump pressure and floats the actuator in the neutral position. The two-position type is used to maintain the system pressure during the spool transition. Shock is reduced compared to the type “2.”
“40” ABT Connected, with Throttle			A variation of the type “4,” having throttles between A to T and B to T. It can quickly stop the actuator.
“5” PAT Connected			Used to unload the pump in the neutral position and stop the actuator by feeding flow in one way.
“6” PT Connected (Closed during Transition)			Unloads the pump and maintains the actuator in the neutral position. It allows valves to be connected in serial.
“60” PT Connected (Opened during Transition)			A variation of the type “6.” Each port is connected to the tank during the spool transition; thus, shock can be reduced.
“7” Center Opened, with Throttle			Mainly used for the two-position type; shock can be reduced during the spool transition.
“8” Two-Way			Maintains the pump pressure and cylinder position in the neutral position, similar to the type “2.” Used as a two-way directional control valve.
“9” PAB Connected			Forms a differential circuit in the neutral position.
“10” BT Connected			Prevents one-way minor sliding of the actuator due to leak at the port P in the neutral position.
“11” PA Connected			Blocks one end and feeds flow from the other end to completely stop the actuator in the neutral position.
“12” AT Connected			Able to prevent the actuator from minor one-way sliding due to leak at the port P in the neutral position.

### 4-1-3 Classifications by Operation Method and Spring Arrangement

These valves are classified according to the function, operation method, and spring arrangement. The operation method is classified into: manual, mechanical, hydraulic, solenoid-operated, electro-hydraulic, and pneumatic. The spring arrangement is classified into: spring offset for the

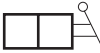
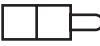
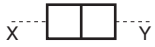
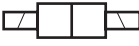
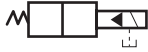
two-position type, spring centered for the three-position type, and no spring for both two- and three-position types. The no-spring type includes the detent type, which holds the spool position at a certain position. Table 4.3 shows classification of the valves according to the operation method and spring arrangement.

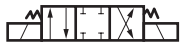
Table 4.3 Classification by Operation Method and Spring Arrangement

Classification		Graphic Symbols	Remarks
Operation Method	Manual		Operated manually with a lever.
	Mechanical		Operated by mechanical components, including cam follower.
	Pilot-Operated (Hydraulics)		Operated by pilot.
	Solenoid-Operated		Operated by an electromagnetic force.
	Electro-Hydraulic		The main spool is operated by electromagnetic-force controlled pilot.
Spring Arrangement	Spring Offset		The control force switches on/off. Without the force, the piston returns to the offset position by the spring force.
	Spring Centered		Without the control force, the spool returns to the neutral position by the spring force.
	No-Spring		The spool is maintained at the controlled position. Detent types that prevent the spool from sliding are also included in this category.

## 4-2 Structure and Characteristics of Directional Control Valves

### 4-2-1 Solenoid Operated Directional Valves

These valves control the flow direction in hydraulic circuits, electrically operated with manual switches, limit switches, or pressure switches. They are the most popular for use in practical hydraulic systems. Three types of solenoids are available: for direct current (DC), for alternating current (AC), and with a rectifier. The solenoids can be grouped into wet and dry types in respect to the structure. Also, the explosion-proof type is available for special purposes. The solenoid with a rectifier consists of a DC solenoid, a rectifier, and a surge absorber; therefore, it can be used for systems operated with AC power supply. This type of the solenoid is characterized by its low noise and low hydraulic shock during the operation. In addition, it assures the non-burnout feature of the coil when the spool is stuck at the half way point of its changeover.

The solenoid operated directional valves are commercially available in the following sizes: less than 1/8, 1/8, 3/8, 1/2, 3/4, and 1 1/4. Among them, the 1/8 size is most often selected for practical hydraulic systems. Figure 4.1 shows the 1/8 solenoid operated directional valve (DSG-01), and Table 4.4 lists the major specifications of the standard and shockless types.

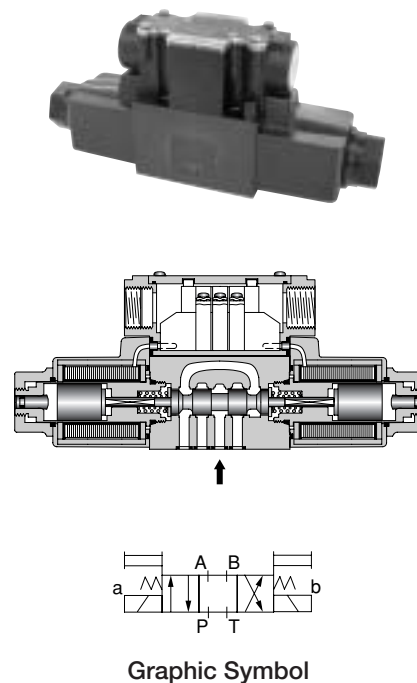

Fig. 4.1 Solenoid Operated Directional Valve, Size 1/8 (DSG-01)

**Table 4.4 Specifications of Solenoid Operated Directional Valves, Size 1/8 (DSG-01)**

Type	Model Numbers	Max. Flow* L/min (U.S.GPM)	Max. Working Pressure MPa (psi)	Max. Tank- Line Back Pressure MPa (psi)	Max. Changeover Frequency min <sup>-1</sup>	Approx. Mass kg (lbs.)
Standard Type	DSG-01-3C※-※-70	100 (26.4)	35 (5 076)	21 (3 046)	300 (R Type Solenoid Only) 120	1.85 (4.08)
	DSG-01-2D2-※-70					
	DSG-01-2B※-※-70					
Shockless Type	S-DSG-01-3C※-※-70	63 (16.6)	25 (3 626)	21 (3 046)	120	1.85 (4.08)
	S-DSG-01-2B2-※-70					1.4 (3.09)

★ The maximum flow refers to the highest flow rate free from any abnormality caused in the valve operation (changeover).

Aside from the maximum working pressure, flow, tank-line back pressure, and changeover frequency, performance characteristics of the solenoid operated directional valves include power consumption. The maximum flow refers to the highest flow rate free from any abnormality caused in the valve operation (changeover), and it is determined by the spool profile and service condition (connecting port, voltage, frequency, etc.). To select appropriate valves for a hydraulic system, it is best to consult with valve

specifications offered by the manufacturers.

Other performance characteristics to be considered are pressure drop and changeover time. Figures 4.2 and 4.3 show the pressure drop characteristics of the standard and shockless types, respectively. The pressure drop depends on the spool profile in the valves. Table 4.5 indicates changeover time, which varies according to the solenoid type.

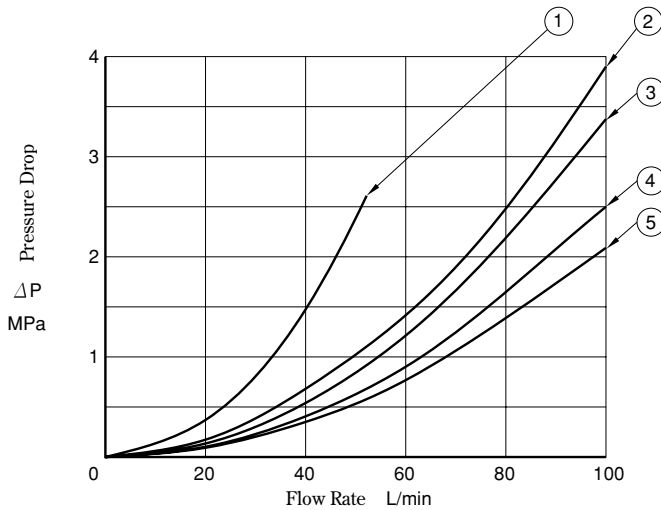

Model Numbers	Pressure Drop Curve Numbers				
	P→A	B→T	P→B	A→T	P→T
DSG-01-3C2	④	④	④	④	—
DSG-01-3C3	⑤	⑤	⑤	⑤	②
DSG-01-3C4	④	④	④	④	—
DSG-01-3C40	④	④	④	④	—
DSG-01-3C60	①	①	①	①	②
DSG-01-3C9	⑤	③	⑤	③	—
DSG-01-3C10	④	⑤	④	④	—
DSG-01-3C11	④	④	④	④	—
DSG-01-3C12	④	④	④	⑤	—
DSG-01-2D2	⑤	④	⑤	④	—
DSG-01-2B2	⑤	④	⑤	④	—
DSG-01-2B3	⑤	⑤	⑤	⑤	—
DSG-01-2B8	⑤	—	④	—	—

**Fig. 4.2 Pressure Drop, Solenoid Operated Directional Valve, Size 1/8, Standard Type: DSG-01**

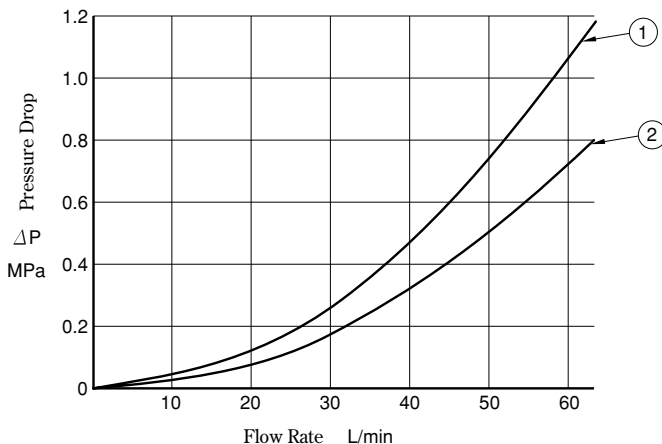

Model Numbers	Pressure Drop Curve Numbers			
	P→A	B→T	P→B	A→T
S-DSG-01-3C2	①	①	①	①
S-DSG-01-3C4	①	②	①	②
S-DSG-01-2B2	①	①	①	①

**Fig. 4.3 Pressure Drop, Solenoid Operated Directional Valve, Size 1/8, Shockless Type: S-DSG-01**

**Table 4.5 Changeover Time of Solenoid Operated Directional Valve, Size 1/8**

Type	Model Numbers	Time ms	
		T <sub>1</sub>	T <sub>2</sub>
Standard Type	DSG-01-3C2-A※	15	23
	DSG-01-3C2-D※	48	19
	DSG-01-3C2-R※	50	100
Shockless Type	S-DSG-01-3C2-D※	70	30

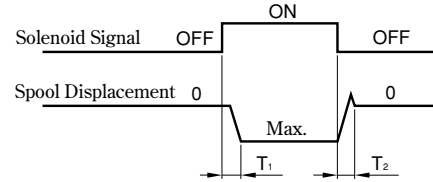

**4-2-2 Solenoid Controlled Pilot Operated Directional Valves**

These valves are a combination of a small solenoid operated directional valve and a large pilot operated directional valve. The small four-way solenoid valve is used for directional control of the pilot line. The main valve (main spool) provides directional control of the main line. The pilot operated directional valve includes the spring offset, spring-centered and no-spring types. The main valve (main spool) combinations are as shown in Table 4.6. A pilot choke can be installed between the pilot valve and the main spool to adjust the pilot flow for

decreasing the changeover speed of the main spool. Thus, shock upon actuator start or stop can be reduced. Delay of the spool response to a solenoid changeover varies according to the fluid viscosity and the pilot pressure and flow. The pilot pressure must be 0.5 to 1 MPa (72.5 to 145 psi) or higher. Table 4.6 shows combinations of pilot operated directional valves and main spools. Figure 4.4 shows a solenoid controlled pilot operated directional valve of the 3/4 size (DSHG-06). Table 4.7 and Figure 4.5 show the specifications and changeover time of the valve.

**Table 4.6 Combinations of Pilot Operated Directional Valves and Main Spools**

Model Numbers	Name	Pilot Valve	Main Valve (Main Spool)
DSH※-2B※	Spring Offset	DSG-2B2	2N※ No Spring
DSH※-3C※	Spring Centered	DSG-3C4	3C※ Spring Centered
DSH※-2N※	No Spring	DSG-2N2	2N※ No Spring
		DSG-2D2	2N※ No Spring

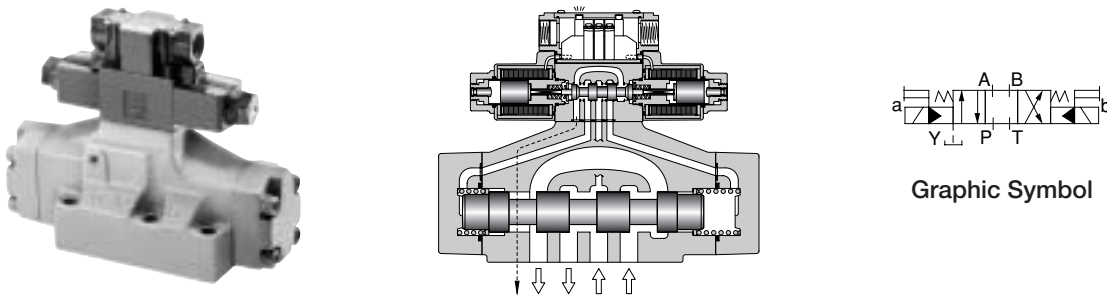

**Fig. 4.4 Solenoid Controlled Pilot Operated Directional Valves, Size 3/4**

**Table 4.7 Specifications of Solenoid Controlled Pilot Operated Directional Valve, Size 3/4**

Model	DSHG-06
Max. Flow	500 L/min (132 U.S.GPM)
Max. Operating Press.	31.5 MPa (4 569 psi)
Max. Pilot Press.	25 MPa (3 626 psi)
Min. Pilot Press.	0.8 MPa (116 psi)
Tank-Line Back Press.	21 MPa (3 046 psi)
Max. Changeover Frequency	120 Times/min

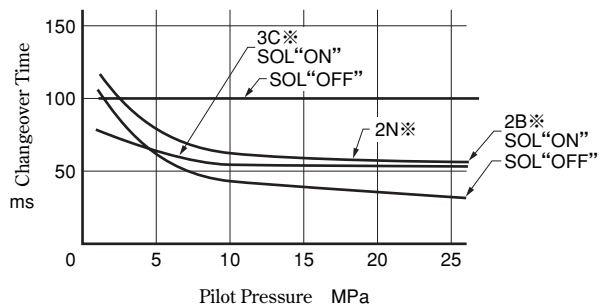
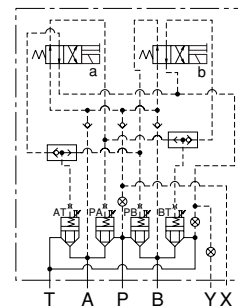
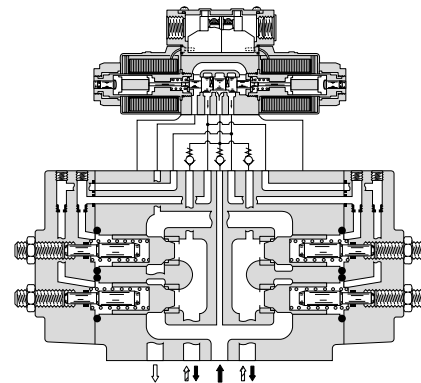
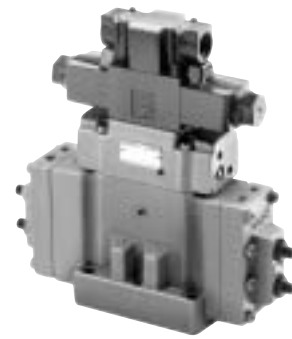

**Fig. 4.5 Changeover Time of Solenoid Controlled Pilot Operated Directional Valve, Size 3/4**  
(Viscosity : 35mm<sup>2</sup>/s DC Rated Voltage)

### 4-2-3 Poppet Type Solenoid Controlled Pilot Operated Directional Control Valves

These valves are solenoid controlled pilot operated directional valves, which are made multi-functionable by granting individual poppet functions, such as directional control, flow control, and pressure control. They consist of a main valve with four poppets, a solenoid operated directional valve for the pilot line, and a pilot selector valve. These valves are used in large-scale hydraulic systems including press and compressing machines. They have mounting faces of the same size as those of the conventional spool valves; however, they provide the following features.

- (1) They have three functions in one body: directional control, flow control, and check valve for pilot operation (counterbalance valve). They reduce the number of valves in applications and installation space.
- (2) Changeover response time is short as the valves are the poppet type. This characteristic eliminates valve overlap. Neither hydraulic leakage from the seat parts nor hydraulic locking is expected.
- (3) By selecting proper orifice diameters for the pilot, open/close timing of the flow passage can be set freely. Therefore, together with the shockless type poppets, a smooth start/stop of the actuators can be achieved. Both the noise of the actuator operation switch and line vibration in hydraulic systems can also be minimized.
- (4) Control of the pilot line offers independent open/close operation of four poppets; the four-position four-way valve type is also available to create a differential circuit. By adopting a differential circuit, gaining high-speed feed by using a smaller volume pump is possible, and the electric power for the systems can be saved.



Graphic Symbol

Fig. 4.6 Poppet Type Solenoid Controlled Pilot Operated Directional Valve

Figure 4.6 shows the poppet type solenoid controlled pilot operated directional valve (DSLHG-06), and Table 4.8 shows examples of the valve functions.

Table 4.8 Examples of the Valve Functions

Directional Control	Flow Control	Pilot Operated Check Valve															
<div style="text-align: center;"> #1 #2 #3 #4  A B    P T </div>	 A B Directional function P T	 A B Directional function P T															
<table border="1" style="width: 100%; text-align: center;"> <thead> <tr> <th>Changeover position</th> <th>#1</th> <th>#2</th> <th>#3</th> <th>#4</th> </tr> </thead> <tbody> <tr> <td>SOL a</td> <td>ON</td> <td>OFF</td> <td>ON</td> <td>OFF</td> </tr> <tr> <td>SOL b</td> <td>OFF</td> <td>OFF</td> <td>ON</td> <td>ON</td> </tr> </tbody> </table>	Changeover position	#1	#2	#3	#4	SOL a	ON	OFF	ON	OFF	SOL b	OFF	OFF	ON	ON		
Changeover position	#1	#2	#3	#4													
SOL a	ON	OFF	ON	OFF													
SOL b	OFF	OFF	ON	ON													



#### 4-2-4 Shut-off Type Solenoid Operated Directional Valves (Poppet Type Two-Way Solenoid Operated Directional Valves)

These valves are solenoid-operated two-way directional valves that operate a poppet valve by the solenoid to open/close hydraulic passages. Two types of them are available: cartridge and sub-plate mounting. Because they are the poppet type, the internal leakage is almost zero. Figure 4.7 shows the shut-off type solenoid operated directional valve (DSPG-01).

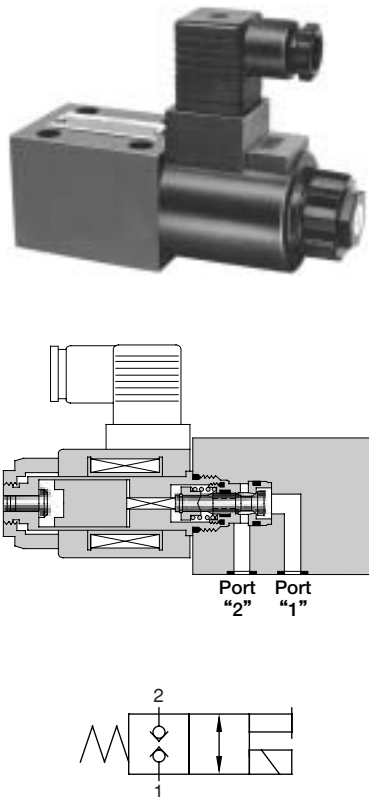
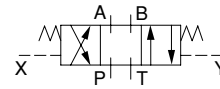
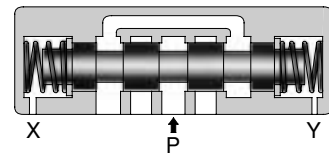

Fig. 4.7 Shut-off Type Solenoid Operated Directional Valve

#### 4-2-5 Pilot Operated Directional Valves

These valves perform spool changeover by the hydraulic pilot. They are useful when the pilot directional control valve and the main directional control valve should be installed distant to each other. The pilot pressure for spool operation is 0.5 MPa (72.5 psi) at minimum. Figure 4.8 shows the pilot operated directional valve (DHG-06).



Graphic Symbol

Fig. 4.8 Pilot Operated Directional Valve

#### 4-2-6 Manually Operated Directional Valves

These valves are manually operated to change the direction of hydraulic flow. They are available in the spool-operated and rotary types. These valves are structured in two types, detent and spring. The detent type maintains the spool position at the time the lever is operated, and the spool is returned to the center by the spring force. The spring type springs back the spool to either position of changeover, as is in the two-position valve. Figure 4.9 shows the spool-operated type and rotary type directional valves, respectively.

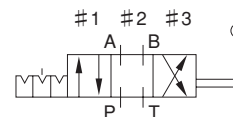
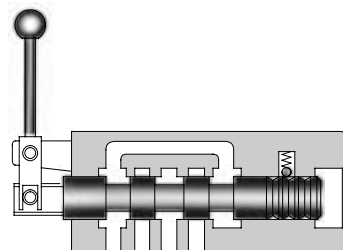

Graphic Symbol

Fig. 4.9 (a) Manually Operated Directional Valve (Spool Operated Type)



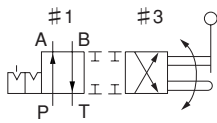
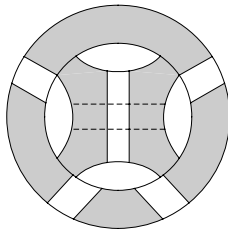

Graphic Symbol

Fig. 4.9 (b) Manually Operated Directional Valve (Rotary Type)

#### 4-2-7 Check Valves

These valves allow free flow in one direction, while preventing flow in the reverse direction. They are used to prevent reversed flow, and two check valve types, in-line and right angle, are available. The poppet opens when the inlet pressure exceeds the spring force. The pressure at which the poppet starts to open is called cracking pressure. Check valves are often incorporated in sequence valves or pressure reducing valves to let them open in one direction and bypass the free flow in the reverse direction.

Figures 4.10 and 4.11 show the in-line and right angle check valves, respectively. Figure 4.12 shows their pressure drop characteristics.

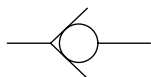
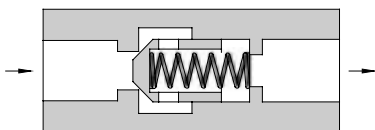

Graphic Symbol

Fig. 4.10 In-Line Check Valve

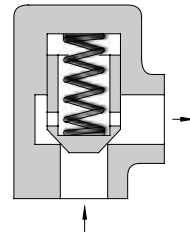
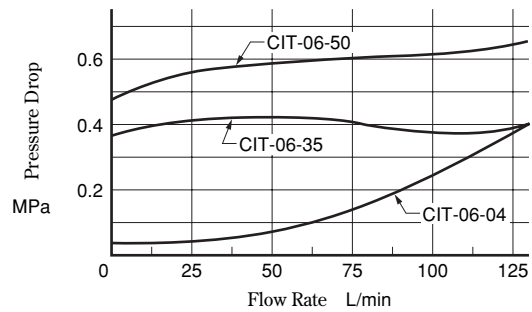
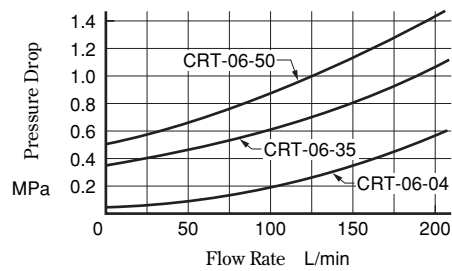

Fig. 4.11 Right Angle Check Valve



In-line Check Valve



Right Angle Check Valve

Fig. 4.12 Pressure Drop (Viscosity : 30 mm<sup>2</sup>/s)

### 4-2-8 Pilot Operated Check Valves

These check valves have a pilot piston, which works with remote pressure to open the closed check valve, allowing reversed flow. Two types, standard and decompression, are available. The decompression type has a main poppet valve combined with a decompression valve. When the pilot pressure increases to lift the pilot piston, the decompression poppet valve opens first, and then the main poppet after the pressure is reduced. These valves are used to moderate shock caused by a sudden pressure release, which often occurs during the return stroke of a press process. They maintain the actuator position and system pressure, opening/closing the seat; therefore, internal leakage can be kept at minimum.

When they are used with a restrictor or a counterbalance valve that produces back pressure on the outlet side of reversed free flow, a counter force may work on the piston, which opens/closes the poppet continuously and vibrates the valves as a result. If the valves are in such a hydraulic circuit, the external drain type should be used. Figure 4.13 shows the pilot operated check valve (CP\*G-06). Figure 4.14 shows the relationship between the minimum pilot pressures and the pressure at the inlet side of reversed free flow. Figure 4.15 shows the pressure drop characteristics in the free flow and in the reversed flow.

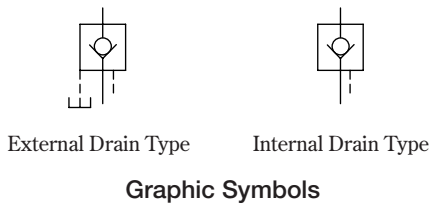
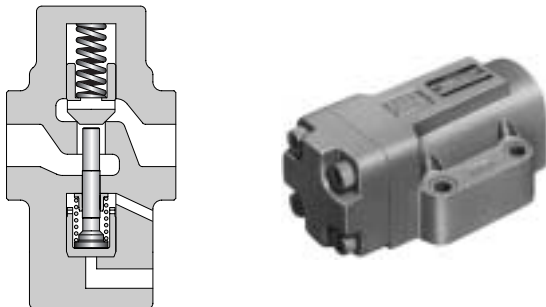

Fig. 4.13 Pilot Operated Check Valve

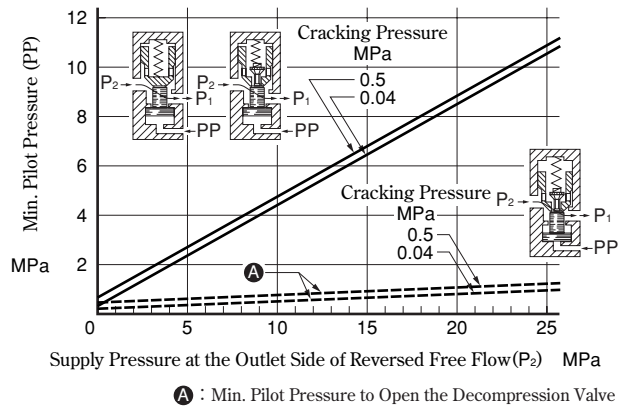

Fig. 4.14 Min. Pilot Pressure

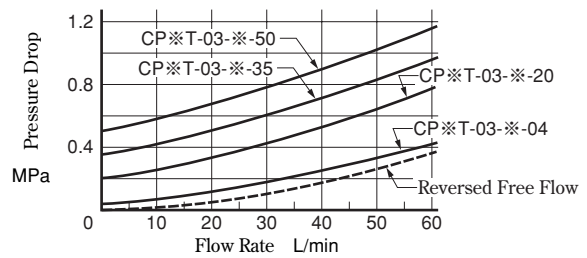

Fig. 4.15 Pressure Drop (Free Flow, Reversed Free Flow)  
Viscosity : 30 mm<sup>2</sup>/s

Figure 4.16 shows circuit examples of the internal and external drain types. When the outlet side  $P_1$  is directly connected to the tank in reversed free flow (a), the internal drain type is normally used. When back pressure is applied to the outlet side  $P_1$  (b), the external drain type should be used.

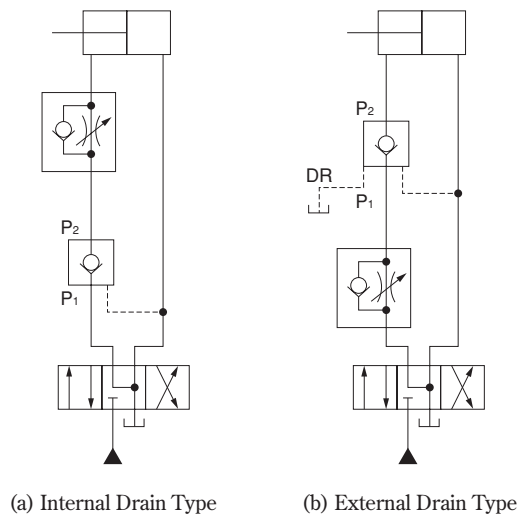

Fig. 4.16 Examples

### 4-2-9 Multiple Control Valves

These valves have multiple functions, including direction, relief, and check control in one body and are mainly used for vehicles. Whether the functions are to be activated individually or simultaneously determines the circuit type: parallel, tandem, or series. When the directional control function is not working, the pump output flow goes through the valve into the tank. For this reason, power loss and heat generation are minimum. The mono block construction, which houses multiple spools in one body, and the sectional construction, which is modular by valve function, are available. For directional control, manual, solenoid, and proportional control valves are offered.

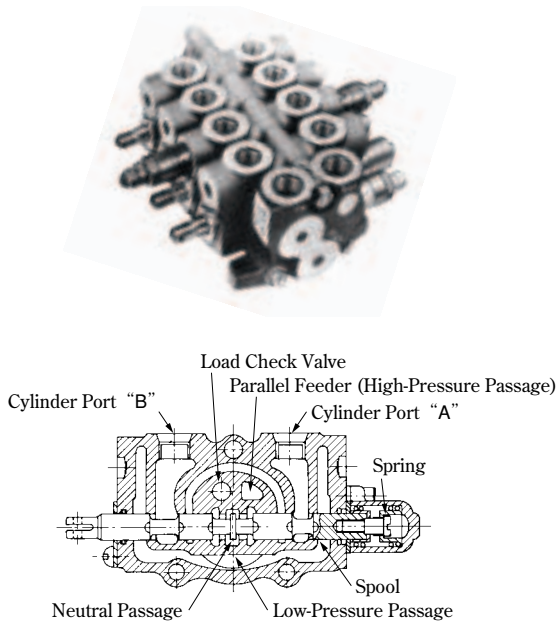
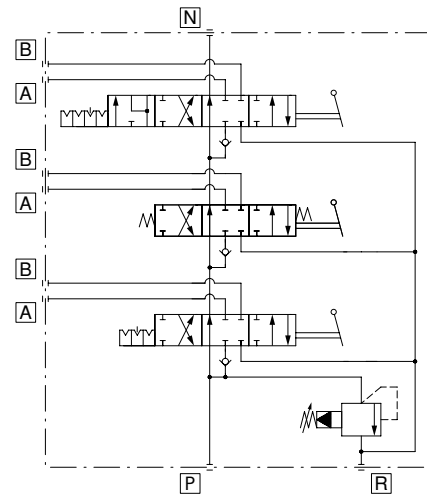
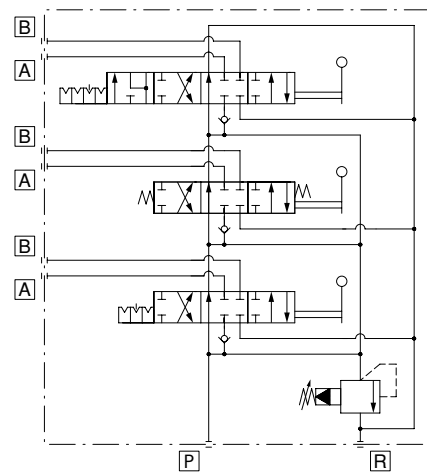

Fig. 4.17 Multiple Control Valve



Tandem Circuit



Parallel Circuit

Fig. 4.18 Graphic Hydraulic Symbols

### History of Solenoid Operated Directional Valve, Size 1/8

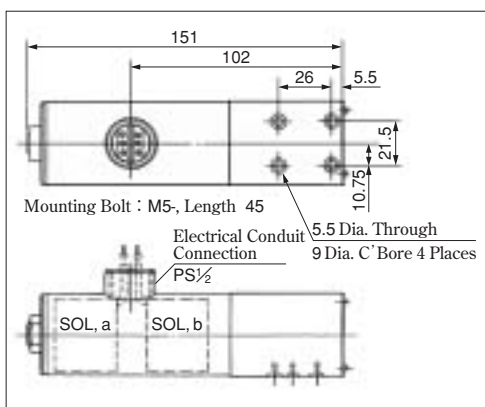

The solenoid operated directional valve in 1/8 size (DSG-01) was first named Design 10 and authorized as a complete engineering release in 1966. Until the release of Design 70 in 2004, its major specifications were updated over 38 years, as shown below. Now, the Design 70 is capable of handling five times the pressure and 16 times the flow rate of the original Design 10; however, the valve mass remains approximately 1.2 times.

Note that the former pressure unit, kgf/cm<sup>2</sup>, is used here for convenience. The conversion to the SI unit is as follows: 1 kgf/cm<sup>2</sup> ≈ 0.1 MPa

Design No.	10	20	21	30	40	50	60	70
Pressure kgf/cm <sup>2</sup>	70	70	140	210	315	315	315	350
Flow Rate L/min	6.3	12	12	12	35	63	63	100
Approx. Mass kg	1.5			2.2			1.85	

# 5

## FLOW CONTROL VALVES

These valves control flow rates in hydraulic circuits and are grouped as follows according to the control to be achieved in respective circuits.

- 5-1 Restrictors/One Way Restrictors
- 5-2 Flow Control Valves/Flow Control and Check Valves
- 5-3 Deceleration Valves/Deceleration and Check Valves
- 5-4 Feed Control Valves
- 5-5 Pilot Operated Flow Control and Check Valves

### 5-1 Restrictors/One Way Restrictors

These valves regulate flow rates in hydraulic circuits. They have the advantages of plain structure, simple operation, and wide range of adjustment. On the other hand, they cannot accurately control the flow; even through the fixed restriction, the flow varies with the inlet-outlet differential pressure and the fluid viscosity. Therefore, these valves are placed where the pressure difference varies little, and high control accuracy is not required. The one-way restrictors regulate flow in one way, while allowing reversed flow to freely pass through.

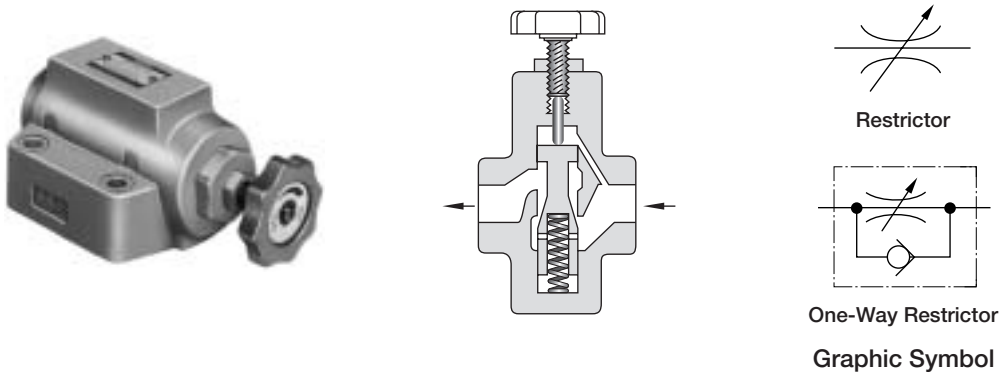

Fig. 5.1 Restrictor

Viscosity of Hydraulic Fluid: 30 mm<sup>2</sup>/s  
 [  $\Delta P$ : Differential Pressure MPa]

● SRT -06, SRCT  
 SRG -06, SRCG -06

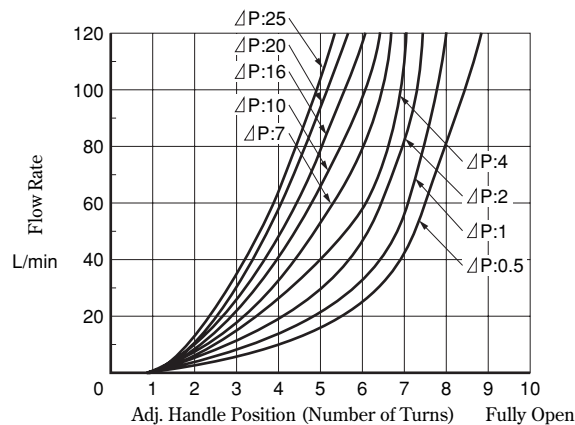

Fig. 5.2 Metred Flow vs. Adjustment Handle Revolutions

## 5-2 Flow Control Valves/Flow Control and Check Valves

These valves consist of a pressure compensator (pressure reducing valve that keeps the pressure difference constant) and a restrictor. They maintain a constant flow rate, independent of the inlet-outlet differential pressure. Provided with a sharp-edge orifice, they can also work regardless of fluid temperature or viscosity.

In a circuit where the flow rate is regulated to a low level, the control flow may be momentarily exceeded, leading to jumping of the actuator. This phenomenon is related to a time lag until the pressure compensating piston is properly positioned for flow control. To prevent the phenomenon, the piston stroke should be adjusted according to the inlet-outlet differential pressure.

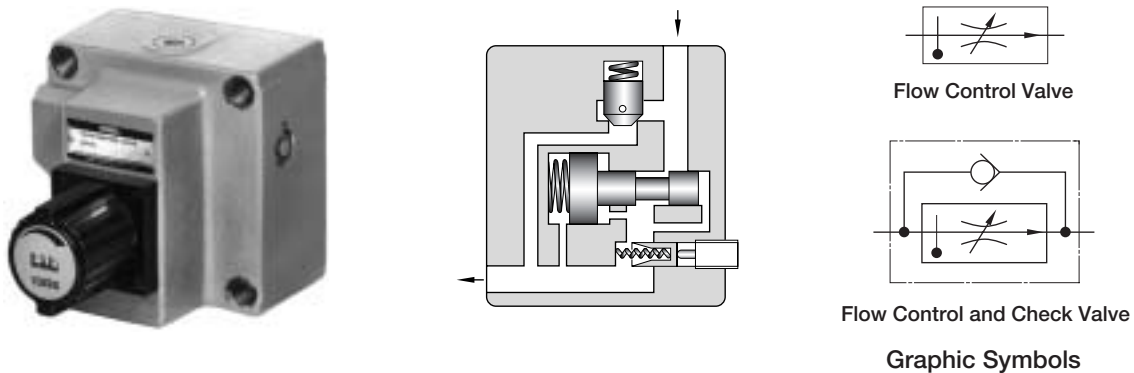

Fig. 5.3 Flow Control Valve

Flow control valves are basically used as follows.

### (1) Meter-In Control

The control valve is connected in series with the cylinder inlet to directly control the input flow. Prior to the control valve, a relief valve is applied to excess flow, which escapes through a relief valve. In a circuit where load is applied in the direction of piston travel, the control valve may lose cylinder speed control.

### (2) Meter-Out Control

The control valve is connected in series with the cylinder outlet to directly control the output flow. Prior to the control valve, excess flow escapes through a relief valve to a tank. This circuit design is used for applications where the piston could move down faster than a control speed, as in the case of vertical drilling machines, or where there should always be a back pressure in the cylinder. Careful attention should be paid to the fact that the cylinder outlet pressure may rise above the relief pressure produced in the circuit.

### (3) Bleed-Off Control

The control valve is installed on a by-pass line to regulate flow to the tank and control the actuator speed. Compared to the other control circuits, this circuit works with small power consumption because the pump's discharge pressure is fully delivered to the load resistance. Given that the bleed flow is constant, the fluctuation of pump flow determines the actuator speed. In other words, the pump discharge flow directly influences the load and the pump's volumetric efficiency.

This circuit does not allow for control of multiple actuators.

Figure 5.4 shows flow control circuits provided with the control types (1) to (3). PG\* indicates the pressure at each point observed when the cylinder is operated at the load pressure of 4 MPa (580 psi). The mechanisms of the meter-in and -out control can be understood by comparing the positions and inlet/outlet pressures of the flow control valves and the inlet/outlet pressures of the cylinders in the meter-in and -out control circuits. The higher cylinder outlet pressure in the meter-out control circuit suggests that the cylinder area difference results in pressure intensification. Also, differences between the bleed-off control and the other control types are clear in the relief valve pressures and the cylinder inlet pressures. The pressure values in the figure are based on the assumption that there are no pipe resistance and pressure loss through the valves.

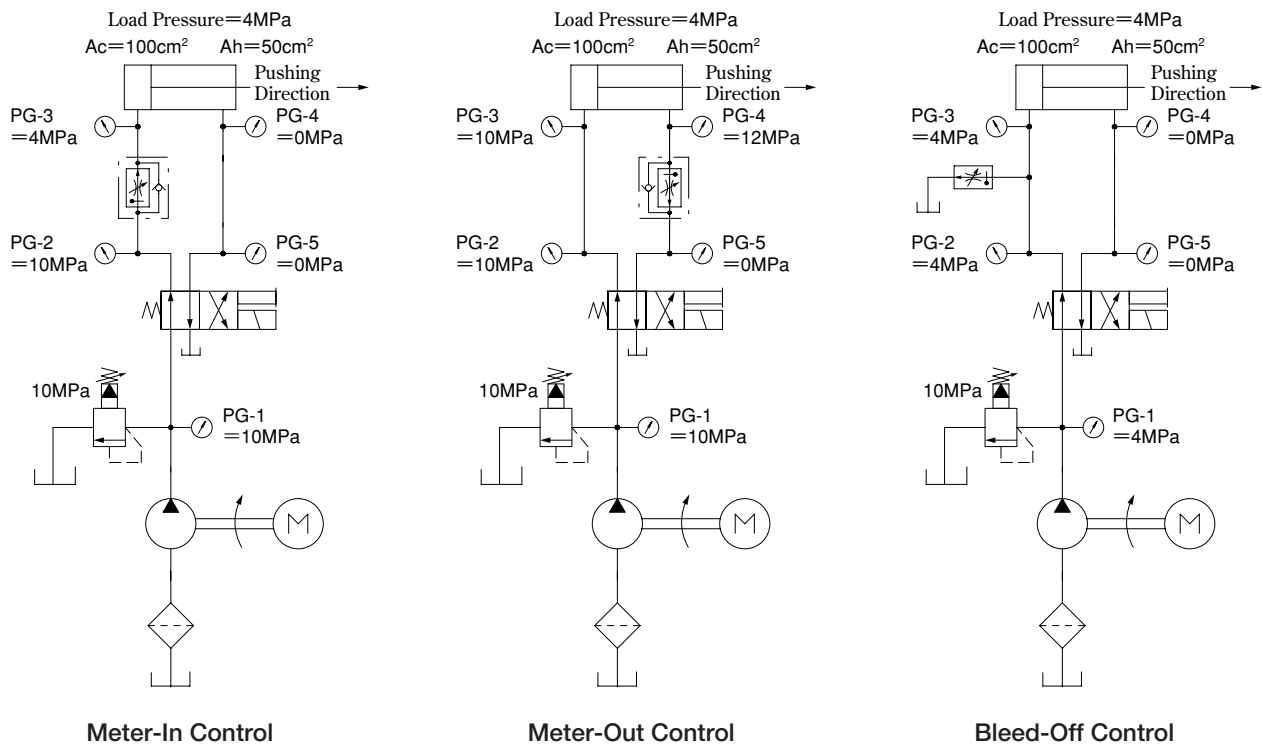
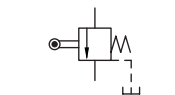
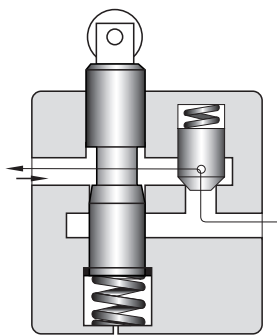

Fig. 5.4 Examples of Control Circuits Using Flow Control Valves

**5-3 Deceleration Valves/Deceleration and Check Valves**

These valves continuously regulate flow rates, using a cam mechanism. Pushing the spool down decreases the flow rate for the normal open type and increases it for the normal close type. When the normal open type is installed to cushion the cylinder piston, accurate stroke end control is difficult. In this case, the restrictor and directional control valve should be adjusted so that the piston slowly returns to an intended position and then stops.



Deceleration Valve

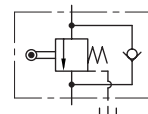

Deceleration and Check Valve

Graphic Symbols

Fig. 5.5 Deceleration and Check Valve (Normal Close Type)

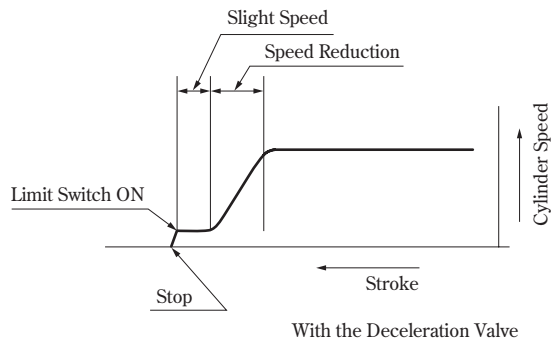

Fig. 5.6 Cylinder Speed Control

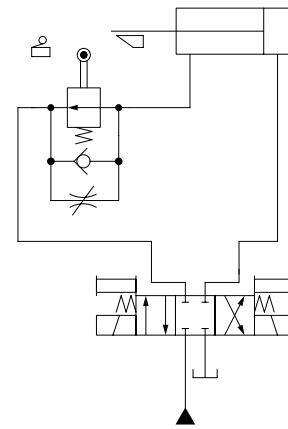
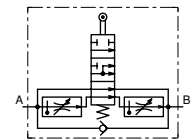
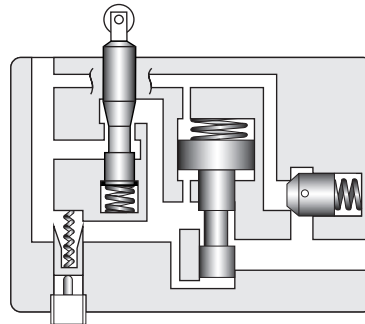

Fig. 5.7 Example

### 5-4 Feed Control Valves

These valves are a combination of a flow control and check valve and a deceleration valve; they are used mainly for feed control of machine tools. Switching from rapid traverse to feed is made by a cam operation, and the feed speed is controlled with a flow control valve. Rapid return is free of cam actuation. Two-speed mode with two flow control valves is also available.



UCF2G-03-※-10

Graphic Symbol

Fig. 5.8 Feed Control Valve

#### Feed Control Valve Released in 1965



● **Features**

1. Provides seamless feeding speed control in two modes (regardless of the cutting resistance and the fluid temperature)
2. Very compact, compared to previous feed control valves.
3. Can be easily mounted/demounted with gaskets.
4. Allows direction switching to be made either with a solenoid pilot or manually.

● **Specifications**

- Max. Press.: 7 MPa (1 015 psi)
- Max. Flow: 50 L/min (13.2 U.S.GPM)
- Coarse Feed: 2 L/min (.528 U.S.GPM)
- Fine Feed: 0.5 L/min (.132 U.S.GPM)
- Weight: 22 kg (48.5 lbs.)



## 5.5 Pilot Operated Flow Control and Check Valves

These valves are pilot-operated. They control the flow with a hydraulic cylinder to accelerate or decelerate the actuator without shock.

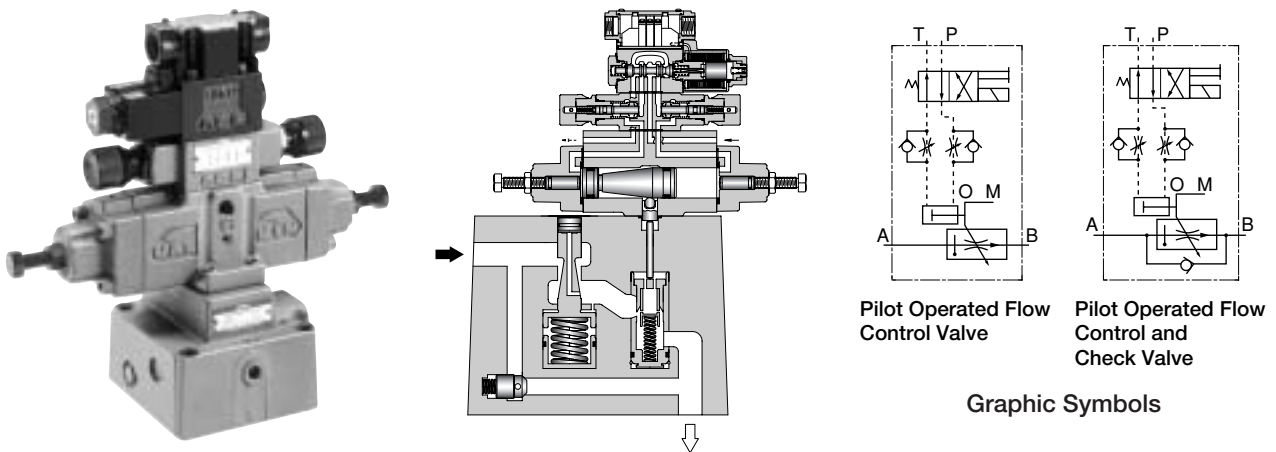

Fig. 5.9 Pilot Operated Flow Control Valve

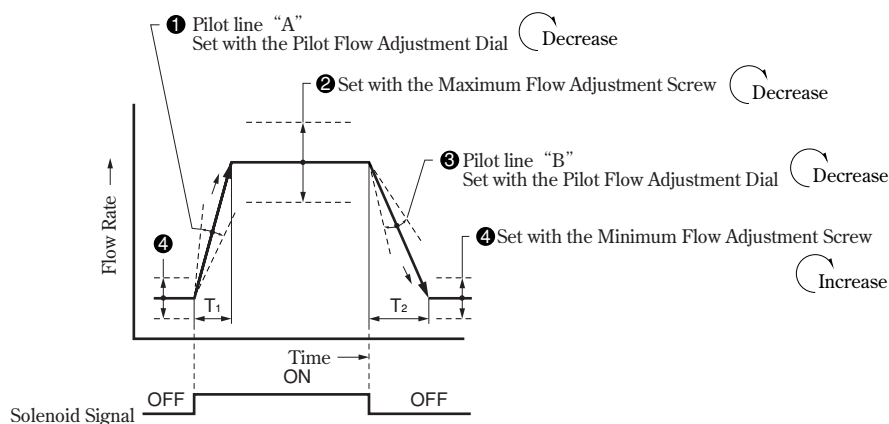

Fig. 5.10 Control Pattern and Flow Rate Adjustment

Other flow control valves described below are available

- **Flow Control and Relief Valves**

These valves contain a flow control valve and a relief valve, the combination of which achieves a pump discharge pressure almost equal to the load pressure. Even when the load pressure is low, the pump discharge pressure does not increase to the control limit, ensuring power-saving operation of the system.

- **Flow Dividers**

These valves are used to synchronize two or more actuators. They have one inlet port and two outlet ports so that the inlet and outlet flows can be regulated to certain levels, regardless of the load.

- **Priority Control Valves**

These valves are incorporated in power source systems for vehicles, etc. If pump supply flow is at or below a preset level, the valves allow all of the flow to go to the priority line. If it is above the preset level, they direct the excess flow to the bypass line.

- **Shut Off Valves**

These valves prevent counter load from decreasing when the cylinder outlet pressure falls because of damaged piping or rubber hoses. When detecting that the cylinder is rapidly moving down, these valves quickly close to shut off the flow.



# 6 MODULAR VALVES

These valves, including the pressure control, flow control, and directional control types, have standardized mounting surfaces that conform to the ISO standards for solenoid operated directional valves. They are stacked on a base plate and referred to as sandwich valves or stack valves. They are available in nominal sizes of less than 1/8 and 1/8 to 1 1/4. Because of easy circuit building, they are more popular than the logic valves described in the next chapter.

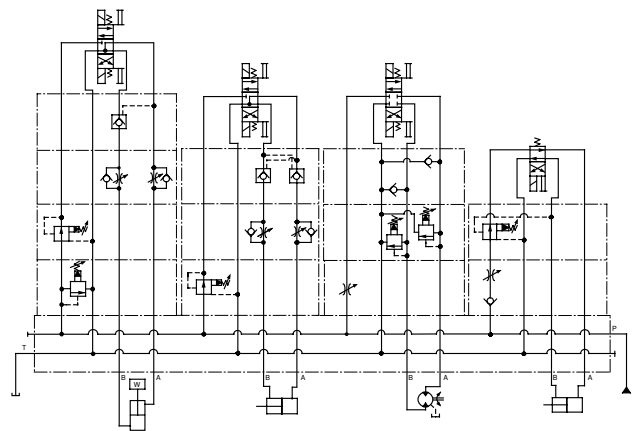
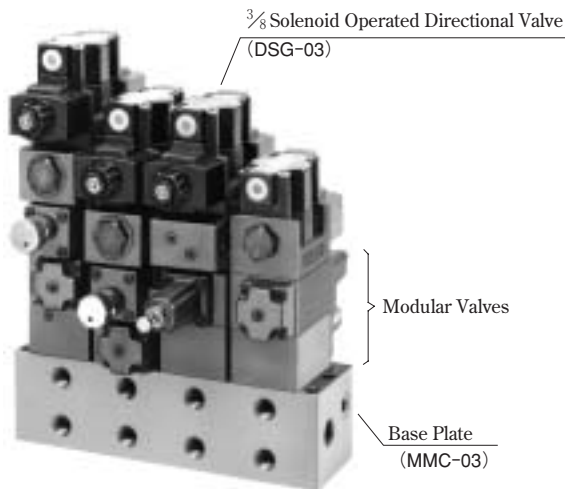

Fig. 6.2 Example of Stacking Configuration

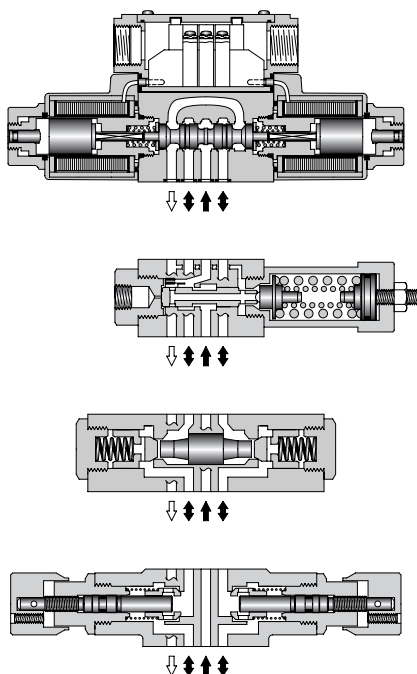

Fig. 6.1 MODULAR VALVES

These modular valves provide the following advantages.

- (1) Compact stacking  
These valves require very small mounting space.
- (2) Easy circuit building  
These valves eliminate the necessity for a large part of piping and assembly work, allowing easy and quick circuit building.
- (3) Improved reliability  
These valves are stacked together without piping; therefore, they are almost free from problems such as oil leakage, vibration, and noise.
- (4) Easy maintenance due to integrated functions

Note that the number of stacking layers is subject to the bolt strength. Also, due caution should be paid to the maximum flow and the pressure loss.

# 7

## LOGIC VALVES

These valves are comprised of cartridge type elements and covers with pilot passages. Although they are two-port valves designed to simply open/close the poppets according to pressure signals from the pilot line, various types may be combined for direction, flow rate, and pressure control. Standard covers, which have several pressure signal ports and control valves, including pilot operated relief valves, are available for control purposes. The covers are spigot mounted so that there is no risk of external oil leakage.

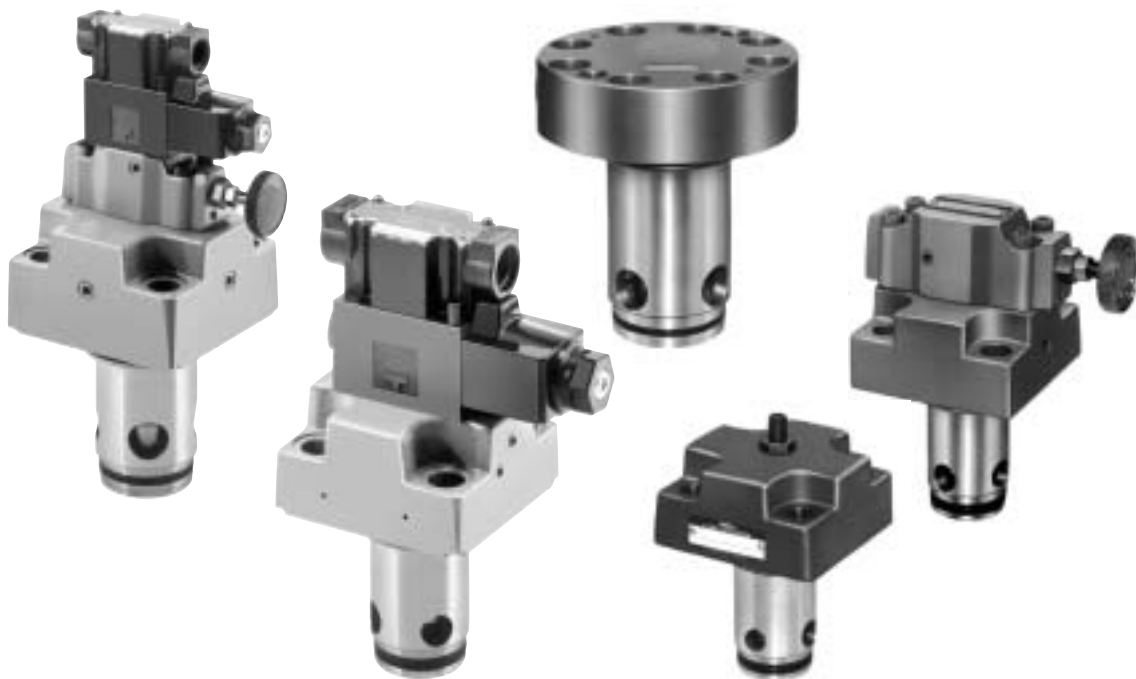

Fig. 7.1 Logic Valves

Logic valves provide fast-response, high-pressure, and high-flow control. They are typically applied to machines that involve high-speed actuator operation, such as die-cast machines, injection molding machines, and press machines. In addition to the general logic valves shown in Fig. 7.1, servo-valve-integrated logic valves, consisting of a cover and a proportional valve or a servo valve, are available for highly accurate control. Such a logic valve accurately determines how much the logic valve opens, based on a deviation between the feedback signal from the displacement sensor on the main spool and the input signal to the proportional or servo valve.

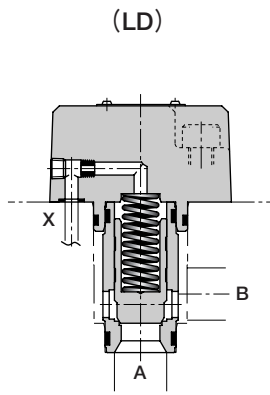

Fig. 7.2 Directional Control Logic Valve

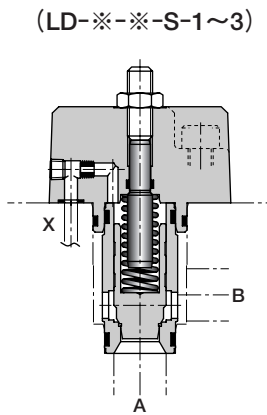

Fig. 7.3 Directional & Flow Control Logic Valve

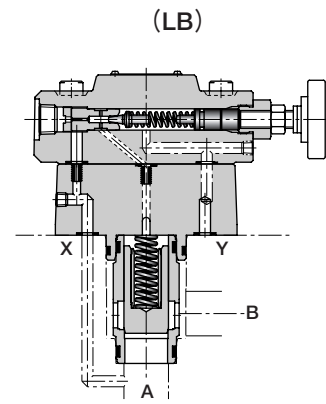

Fig. 7.4 Relief Logic Valve

The logic valves have the following features.

- (1) Multifunction performance in terms of direction, flow, and pressure can be obtained by combining elements and covers.
- (2) Various functions can be achieved, depending on the pilot line connection.
- (3) Poppet-type elements virtually eliminate internal leakage and hydraulic locking. Because there are no overlaps, the response time is very short, permitting high-speed shifting.
- (4) For high pressure, large capacity systems, optimum performance is achieved with low pressure losses.
- (5) Since the logic valves are directly incorporated in cavities provided in blocks, the system faces fewer problems related to piping such as oil leakage, vibration, and noise, and higher reliability is achieved.
- (6) Multi-function logic valves permit compact integrated hydraulic systems that reduce manifold dimensions and mass and achieve lower cost than that of the conventional types.

Table 7.1 List of Cover Types

Cover Type (Designation)	Graphic Symbols	Cover Type (Designation)	Graphic Symbols	Cover Type (Designation)	Graphic Symbols
Directional Control	Standard (None)	Directional & Flow Control	With Stroke Adjuster	Relief	Standard (None)
	With Check Valve		With Check Valve & Stroke Adjuster		Vent Controlled (Z <sub>1</sub> )
	With Shuttle Valve		With Shuttle Valve & Stroke Adjuster		Vent Controlled (Z <sub>2</sub> )

Note) Logic valves containing a solenoid operated directional valve are also available.

Table 7.2 Pilot Line Connections and Functions

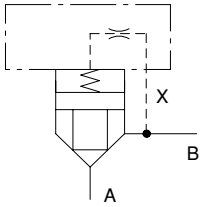
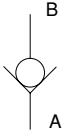
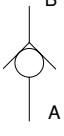
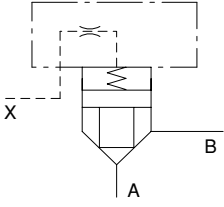
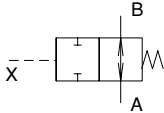
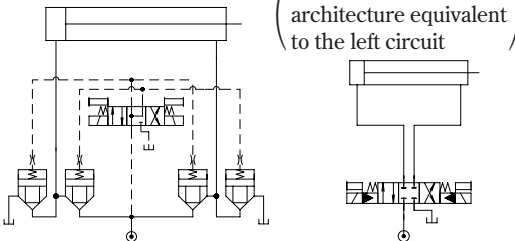
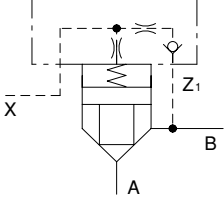
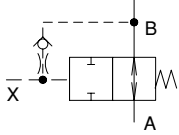
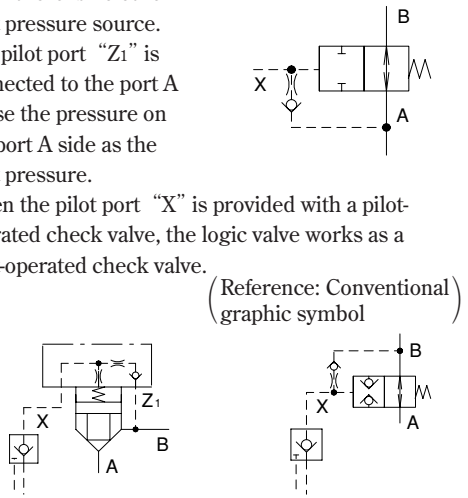
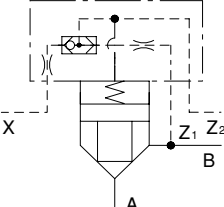
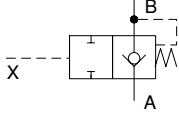
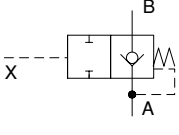
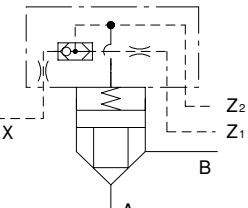
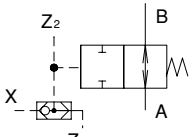
Cover Type	Example of Pilot Line Connection	(Reference) Graphic Symbols	Function and Use
No designation: Standard			<ul style="list-style-type: none"> <li>● Serves as a check valve.</li> <li>● Connecting the pilot port "X" to the port A reverses the free flow.</li> </ul> <p>(Connecting the port X to the port A)</p> 
			<ul style="list-style-type: none"> <li>● Serves as a normal open type shut off valve.</li> <li>● The pilot port "X" is connected to a solenoid operated directional valve, as shown below.</li> </ul> <p>(Conventional circuit architecture equivalent to the left circuit)</p> 
4 : With Check Valve			<ul style="list-style-type: none"> <li>● Allows an in-line pressure to serve as a pilot pressure when there is no other pilot pressure source.</li> <li>● The pilot port "Z1" is connected to the port A to use the pressure on the port A side as the pilot pressure.</li> <li>● When the pilot port "X" is provided with a pilot-operated check valve, the logic valve works as a pilot-operated check valve.</li> </ul> <p>(Reference: Conventional graphic symbol)</p> 
5 : With Shuttle Valve			<ul style="list-style-type: none"> <li>● Serves as a combination of check and shut off valves. The pressure at the pilot port "X" or port B, whichever is higher, is used as the pilot pressure.</li> <li>● Connecting the pilot port "Z1" to the port A reverses the free flow when the spring is at the offset</li> </ul> <p>(Connecting the port Z1 to the port A)</p> 
			<ul style="list-style-type: none"> <li>● Serves as a shut off valve with the pressure at the pilot port "X" or "Z1," whichever is higher.</li> <li>● The pilot ports "X," "Z1," and "Z2" can provide more reliable control, depending on the circuit design.</li> </ul>

# PROPORTIONAL ELECTRO-HYDRAULIC CONTROL VALVES

- 8-1 Proportional Electro-Hydraulic Pilot Relief Valves
- 8-2 Proportional Electro-Hydraulic Relief Valves
- 8-3 Proportional Electro-Hydraulic Relieving and Reducing Valves
- 8-4 Proportional Electro-Hydraulic Flow Control (and Check) Valves
- 8-5 Proportional Electro-Hydraulic Flow Control and Relief Valves
- 8-6 Proportional Electro-Hydraulic Directional and Flow Control Valves
- 8-7 Power Amplifiers For Proportional Electro-Hydraulic Control Valves
- 8-8 Setting Adjusters
- 8-9 Circuit Example of Proportional Electro-Hydraulic Control Valves
- 8-10 Hybrid Proportional Electro-Hydraulic Control Valves

These valves and related devices work with electrical settings to provide continuous remote control of the pressure and flow in hydraulic circuits. For multi-stage pressure or flow control, various combinations of control valves have been used; however, proportional electro-hydraulic control valves and devices eliminate the necessity for those valves and greatly simplify the circuit architectures.

These valves and devices, which permit remote control, allow hydraulic systems and their control rooms to be separately located. In other words, they are well suited for applications in large plants. While servo systems are generally applied to equipment requiring high-speed and high-accuracy control, proportional electro-hydraulic control valves and devices, based on general-purpose hydraulic products, are easy to maintain and manage, highly resistant to contamination by fluids, and cost-effective for applications where very quick response and high accuracy are not required.

## 8-1 Proportional Electro-Hydraulic Pilot Relief Valves

These valves consist of a proportional DC solenoid and a direct type relief valve. Connected to the vent port of a relief valve or a pressure reducing valve, they can continuously control the pressure through a controlled input current to the DC solenoid.

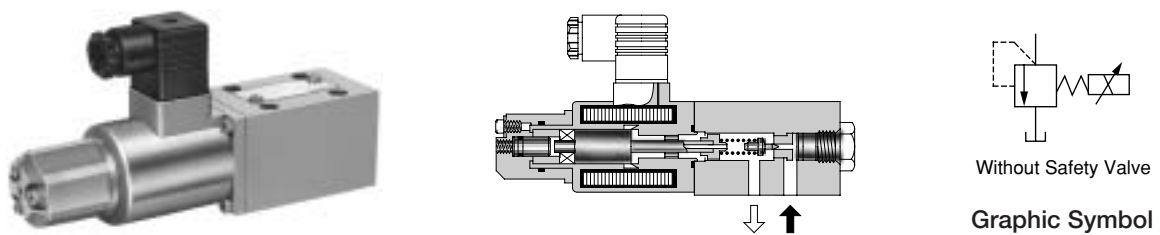

Fig. 8.1 Proportional Electro-Hydraulic Pilot Relief Valves

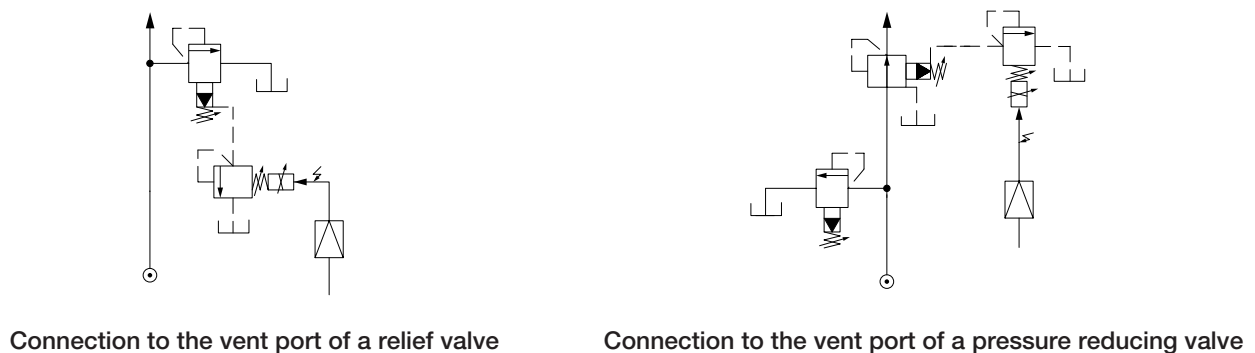

Fig. 8.2 Example

## 8-2 Proportional Electro-Hydraulic Relief Valves

These valves consist of a proportional electro-hydraulic pilot relief valve and a low noise type pilot operated relief valve. They can control the system pressure proportionally through a controlled input current.

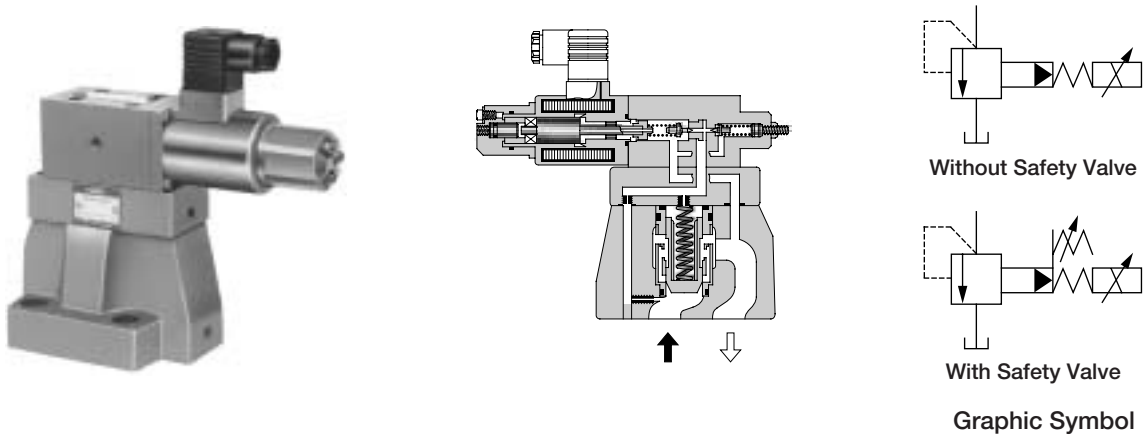

Fig. 8.3 Proportional Electro-Hydraulic Relief and Safety Valve

## 8-3 Proportional Electro-Hydraulic Relieving and Reducing Valves

These valves consist of a proportional electro-hydraulic pilot relief valve and a pressure reducing and relieving valve. They can control the system pressure continuously through a controlled input current to the DC solenoid. Because the valves have a relieving mechanism, a good response speed in reducing the pressure even at a large load capacity can be obtained.

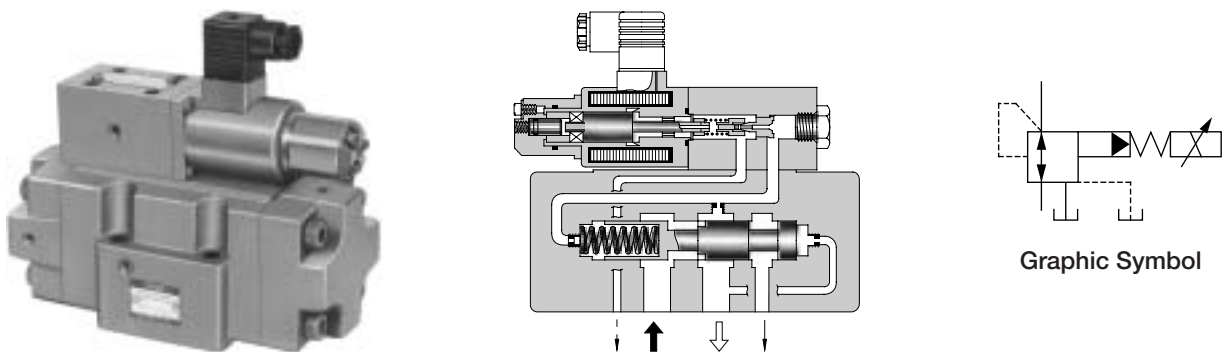

Fig. 8.4 Proportional Electro-Hydraulic Relieving and Reducing Valve

## 8-4 Proportional Electro-Hydraulic Flow Control (and Check) Valves

These valves are flow control valves provided with a proportional DC solenoid on the restrictor. They can smoothly start, stop, and accelerate/decelerate the actuator through a controlled input current.

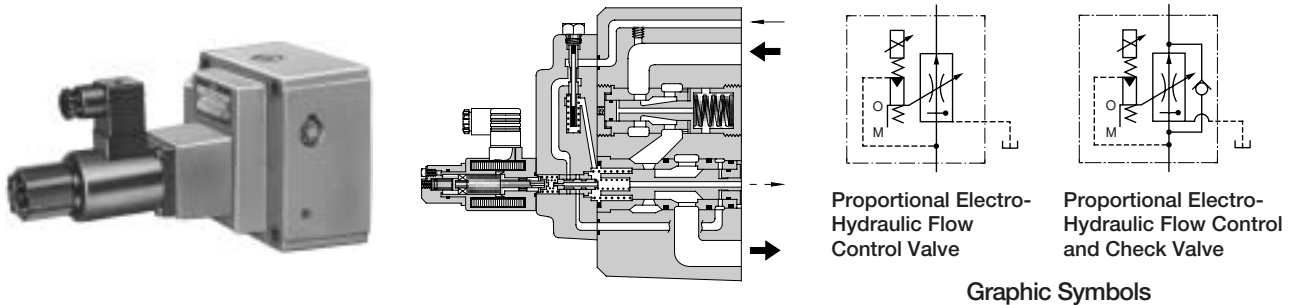

Fig. 8.5 Proportional Electro-Hydraulic Flow Control Valve

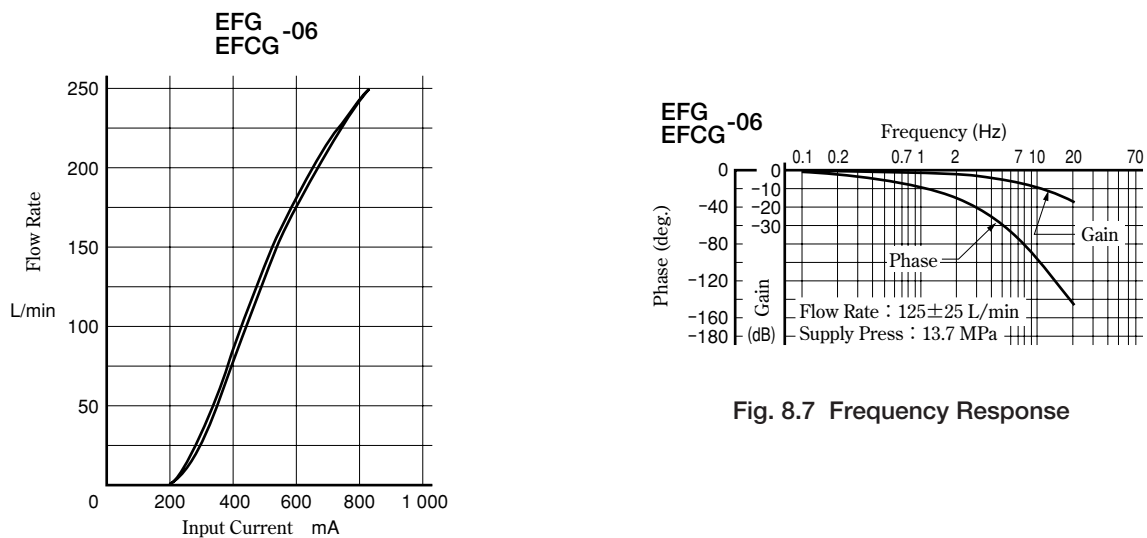

Fig. 8.6 Input Current vs. Flow Rate

Fig. 8.7 Frequency Response

## 8-5 Proportional Electro-Hydraulic Flow Control and Relief Valves

These valves facilitate energy-saving operation of hydraulic systems by supplying the minimum pressure and flow required to drive the actuators. These valves control the pump pressure effectively by responding to a small pressure difference against the load pressure. They could be described as energy-saving meter-in type flow control valves that can be operated at low power consumption. Also, they are provided with a linear variable differential transformer for detecting the throttle position, allowing reliable and high-accuracy control.

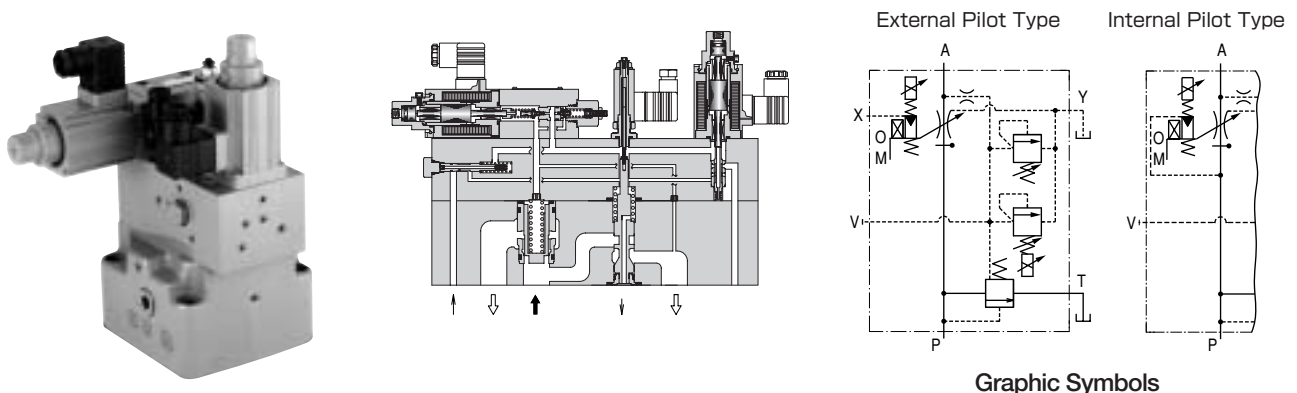
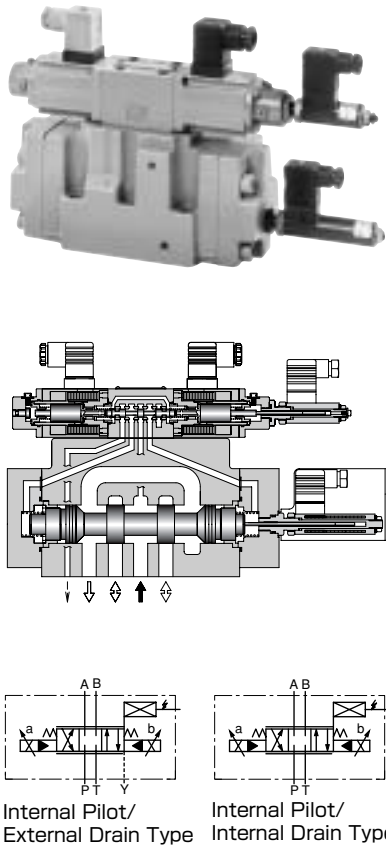

Fig. 8.8 Proportional Electro-Hydraulic Flow Control and Relief Valve



## 8-6 Proportional Electro-Hydraulic Directional and Flow Control Valves

These valves accommodate flow and direction control functions for an actuator. The flow rate can be controlled by changing an input current to the solenoids and the direction of the flow can be controlled by providing the current to either of the two solenoids. These valves have linear variable differential transformers for detection of the spool position so that they can provide quick-response and high-accuracy control. Some of the valves can adjust the spool shift timing for operation without shock.



**Graphic Symbols**

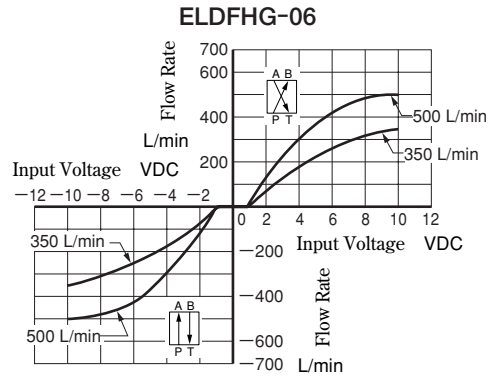

**Fig. 8.10 Input Current vs. Flow Rate**  
(Viscosity: 30 mm<sup>2</sup>/s, Valve Press. Difference: 1 MPa)

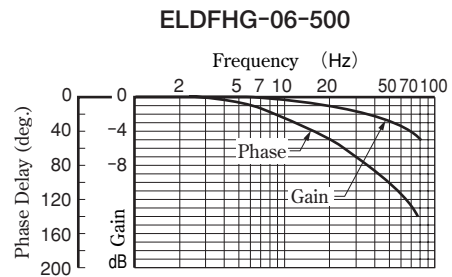

**Fig. 8.11 Frequency Response**  
(Viscosity: 30 mm<sup>2</sup>/s, Supply Press.: 14 MPa, Input Signal: 0±25 %)

**Fig. 8.9 Proportional Electro-Hydraulic Directional and Flow Control Valves**

**Table 8.1 Specifications**

Model Numbers	ELDFG-01-35	ELDFG-03-80	ELDFHG-04-280	ELDFHG-06-500
Rated Flow L/min (U.S.GPM)	35 (9.25) (@ ΔP=1.5MPa (218 psi))	80 (21.1) (@ ΔP=1.5MPa (218 psi))	280 (74.0) (@ ΔP=1MPa (145 psi))	500 (132) (@ ΔP=1MPa (145 psi))
Max. Operating Press. MPa (psi)	31.5 (4 569)	31.5 (4 569)	35 (5 076)	31.5 (4 569)
Max. Return Press. MPa (psi) (External Drain Type)	—	—	31.5 (4 569)	25 (3 626)
Max. Return Press. MPa (psi) (Internal Drain Type)	21 (3 046)	21 (3 046)	21 (3 046)	21 (3 046)
Pilot Press. MPa (psi)	—	—	1.5~31.5 (218~4 569)	1.5~31.5 (218~4 569)
Frequency Response (Amplitude: ±25 %, Phase Delay: -90 Deg.)	48	36~41	46	39
Step Response ms (0→100 %)	30 or less	25~29	13	18
Solenoid Spec. Current	Max. 2.5 A	Max. 3 A	Max. 2.5 A	Max. 2.5 A
Coil Resistance (@20°C)	3.9Ω	3.0Ω	3.9Ω	3.9Ω
Internal Leakage L/min (U.S.GPM) (Supply Press.: 14 MPa (2 031 psi), Pilot Press.: 14 MPa (2 031 psi))	—	Spool Arrangement "3C2": 3 L/min (.793 U.S.GPM) or less, "3C40": 4 L/min (1.06 U.S.GPM) or less, "3C2P": 10 L/min (2.64 U.S.GPM) or less.		
Dust/Water Proof	IP64 compliant			
Ambient Temperature	-15~+60°C (5~140 °F)			

## 8-7 Power Amplifiers For Proportional Electro-Hydraulic Control Valves

Amplifiers serve as a drive for the proportional electro-hydraulic control valves. They convert signal voltage from a setting adjuster to a current. Then, they amplify and feed the current to the solenoid to operate the valves for pressure and flow control. The available types of the amplifiers are: DC input, DC input feedback, slow up-down, DC input with minor feedback, and shock-less.

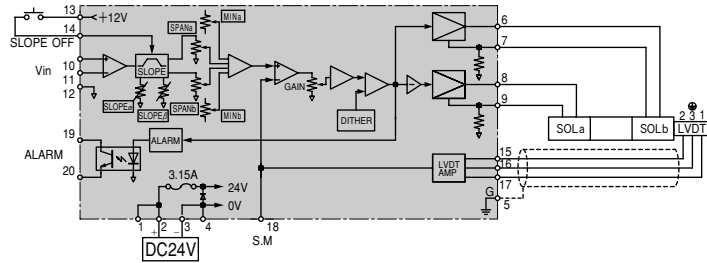

Example

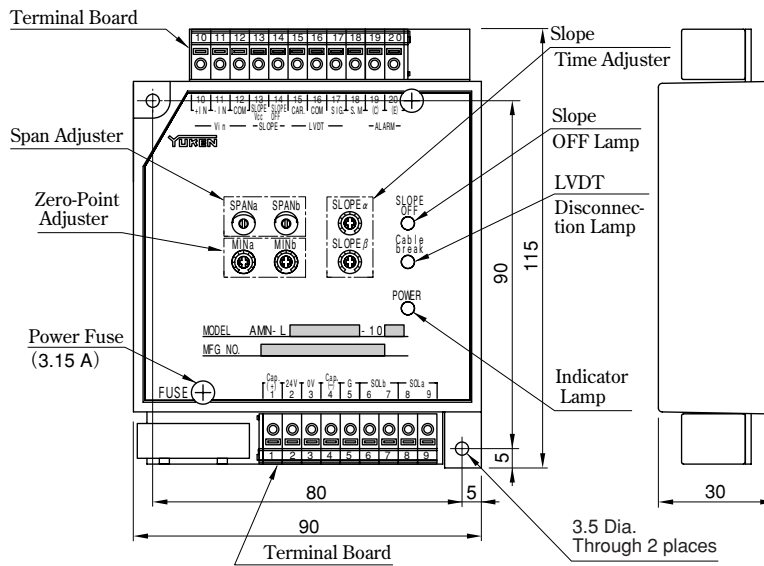
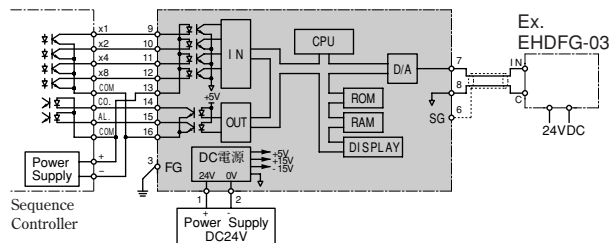

Fig. 8.12 Power Amplifier

## 8-8 Setting Adjusters

Setting adjusters give command signal voltage to the power amplifiers. They are available in the following types: manually operated setting adjusters, 6-point setting adjusters, multifunction slope controllers, and small slope controllers. Which type of setting adjuster is required depends on the actual system operation; generally, it should be determined by each user.



Example

Fig. 8.13 Setting Adjuster

## 8-9 Circuit Examples of Proportional Electro-hydraulic Control Valves

Figures 8.14 and 8.15 compare circuits equipped with the general hydraulic control valves and the proportional electro-hydraulic control valves. As is evident from the figures, the proportional electro-hydraulic control valves can generally replace many of control valves in hydraulic systems. Also, they simplify the circuit and the system sequence, bringing about easier maintenance and management. Furthermore, the proportional electro-hydraulic control valves provide continuous control, which is impossible with any combination of the general hydraulic control valves. With the proportional electro-hydraulic control valves, hydraulic systems may be used in a significantly wider range of application areas.

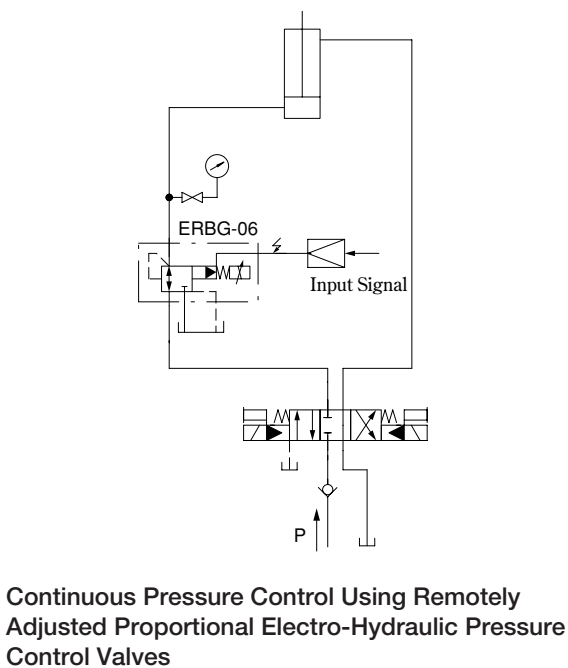
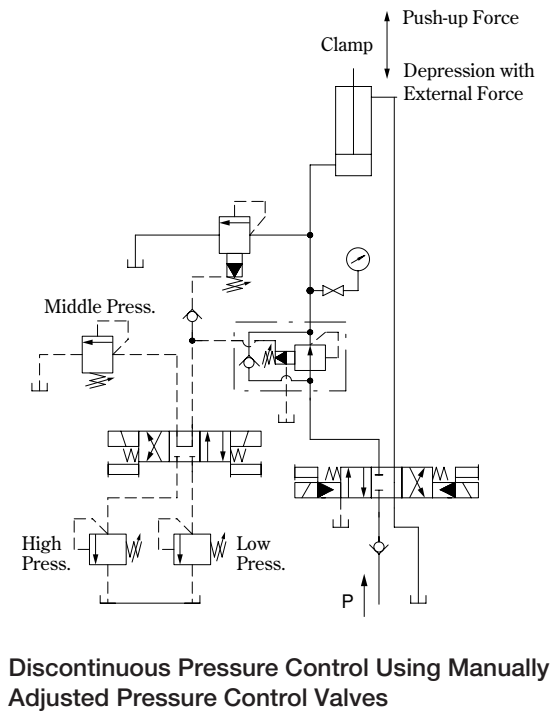

Fig. 8.14 Pressure Control Circuit Example

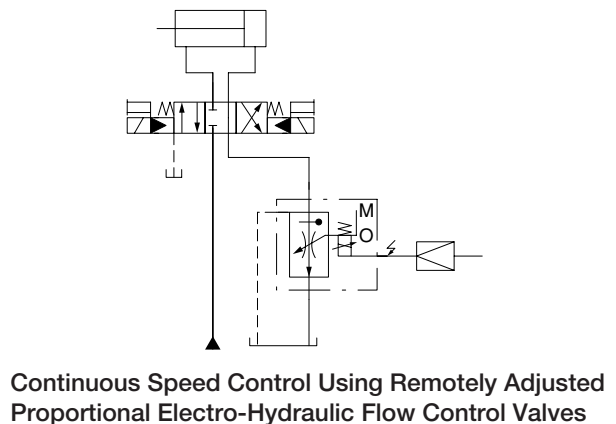
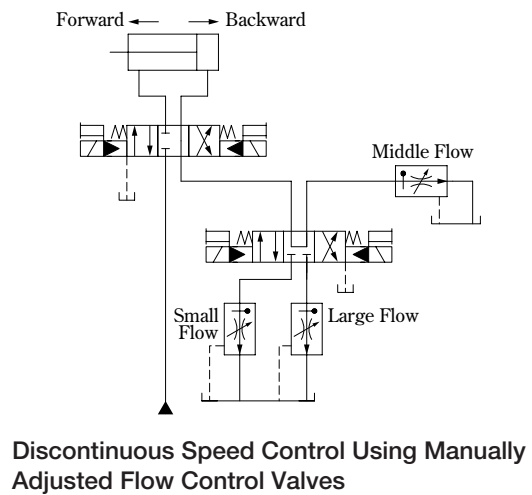
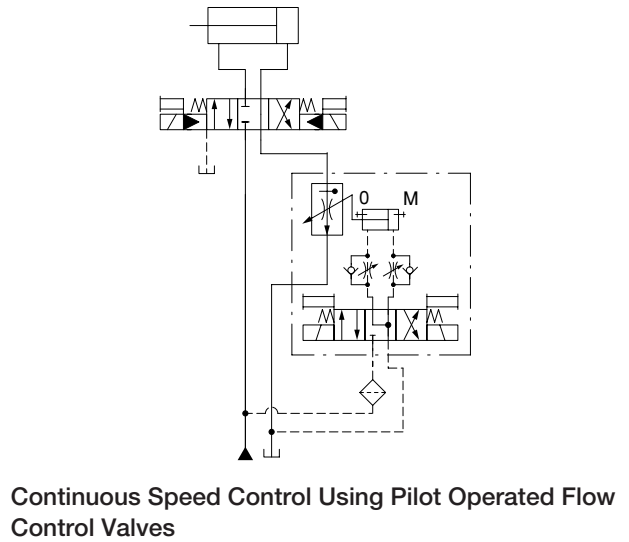

Fig. 8.15 Flow Control Circuit Example

## 8-10 Hybrid Proportional Electro-Hydraulic Control Valves

These valves contain a combination of an amplifier-integrated proportional valve, pressure sensor, and displacement sensor in order to improve the functionality and ease of use. They have a closed minor feedback loop that greatly improves pressure control linearity, hysteresis, and stability. The valves offer the following features.

- (1) With a hydraulic power source, DC 24 V power supply, and command signal voltage (0 to 5 V), the valves allow easy building of proportional control systems and do not require any separate amplifier or electric controller.
- (2) They accommodate sensors that permit system pressures to be monitored on a remote digital indicator.
- (3) The valves feature monitoring of sensor output signals and deviation signals from a closed loop; systems can be built that detect failures of hydraulic components or conduct predictive prognostics.

### 8-10-1 Proportional Electro-Hydraulic Relief Valves with On Board Electronics

These valves consist of a proportional electro-hydraulic relief valve, a power amplifier, and a pressure sensor. They can control hydraulic system pressures proportionally to the controlled input voltage.

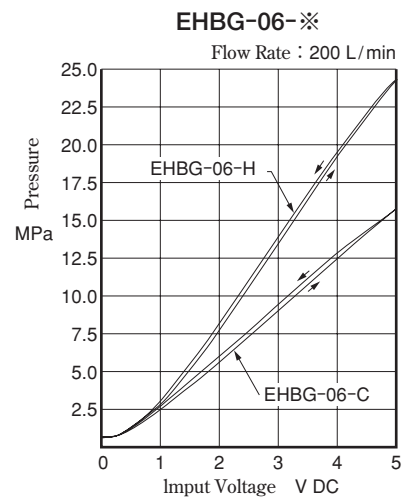

Fig. 8.17 Input Voltage vs. Flow Rate

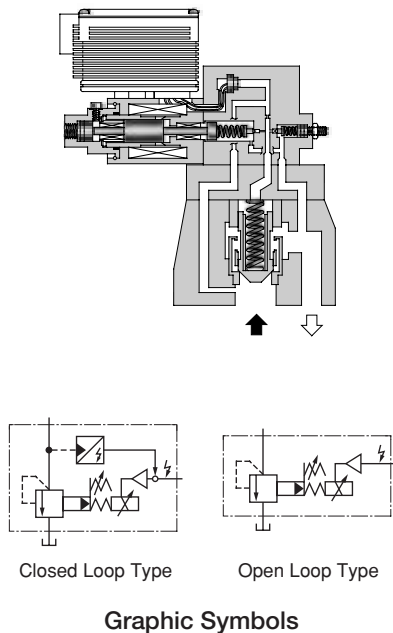

Fig. 8.16 Proportional Electro-Hydraulic Relief Valve with On Board Electronics

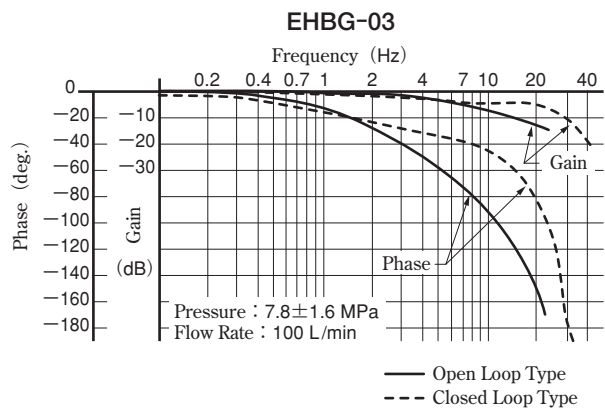
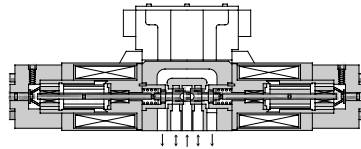

Fig. 8.18 Frequency Response

### 8-10-2 Proportional Electro-Hydraulic Directional and Flow Control Valves with On Board Electronics

These valves are a combination of a directional and flow control valve and a power amplifier. The flow rate can be

controlled by changing an input voltage to the solenoids, and the direction of the flow can be controlled by providing the current to either of the two solenoids. This type of valve is highly popular abroad because of its ease of use.



● Meter-in/Meter-out Control Type

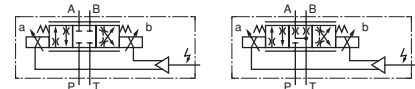

3C2

3C40

Graphic Symbols

Fig. 8.19 Proportional Electro-Hydraulic Directional and Flow Control Valve with On Board Electronics

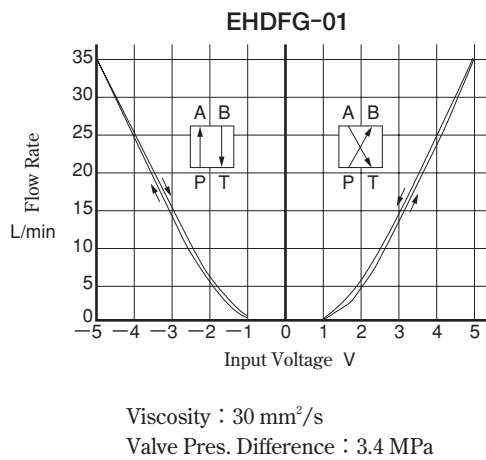

Fig. 8.20 Input Voltage vs. Flow Rate

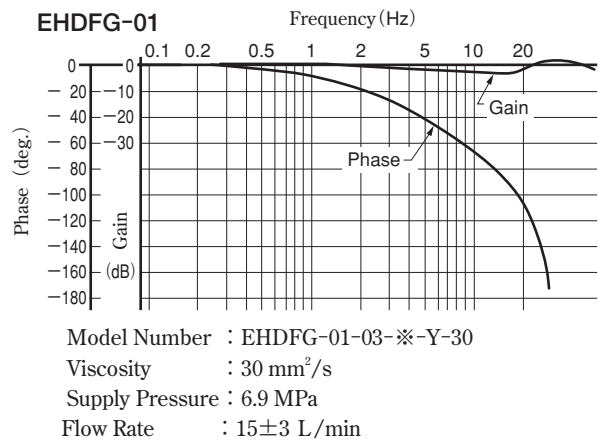
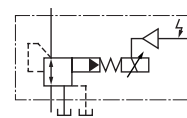
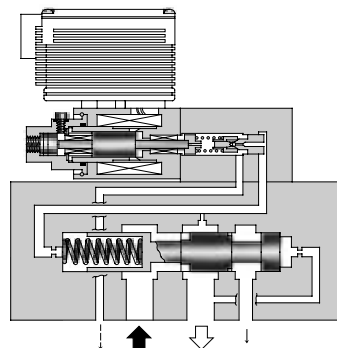

Fig. 8.21 Frequency Response

### 8-10-3 Proportional Electro-Hydraulic Relieving and Reducing Valves with On Board Electronics

These valves are a combination of a proportional electro-hydraulic pilot relief valve and a pressure reducing and

relieving valve. They can control hydraulic system pressures proportionally to the controlled input voltage. As the valves have a relieving mechanism, a good response speed in reducing the pressure, even at a large load capacity, can be obtained.



Open Loop Type

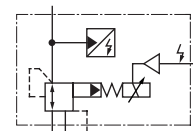

Closed Loop Type

Graphic Symbols

Fig. 8.22 Proportional Electro-Hydraulic Relieving and Reducing Valve with On Board Electronics

# SERVOMECHANISM & SERVO VALVES

- 9-1 Servomechanism (Tracking Mechanism)
- 9-2 Servo Valve Selection
- 9-3 Electro-Hydraulic Two-Stage Servo Valves
- 9-4 Direct Drive Servo Valves
- 9-5 Servo Amplifiers
- 9-6 Sensors
- 9-7 Hydraulic Power Source
- 9-8 Servo Systems with Pump Speed Control
- 9-9 Related Terms

## 9-1 Servomechanism (Tracking Mechanism)

A servomechanism is an automatic control system designed to operate in accordance with input control parameters. The mechanism continuously compares the input signal to the feedback signal to adjust the operating conditions for error correction. Commercially available servo systems vary according to their methods for error detection, amplification, communication, and output.

Hydraulic servo systems have been widely applied in general industrial areas, as well as in the airline, maritime, and military industries. Servo systems, capable of automatic position, speed, and force (load) control with high accuracy and quick response, are used for high-speed injection molding, die-casting, rolling mill, press machines, industrial robots, simulators, testing machinery, and table feeders.

A hydraulic servo system consists of an actuator (hydraulic motor/cylinder), servo valves, sensors, and a servo amplifier, as shown in Fig. 9.1. Figure 9.2 shows a servo system applied to a high-speed vibration test machine.

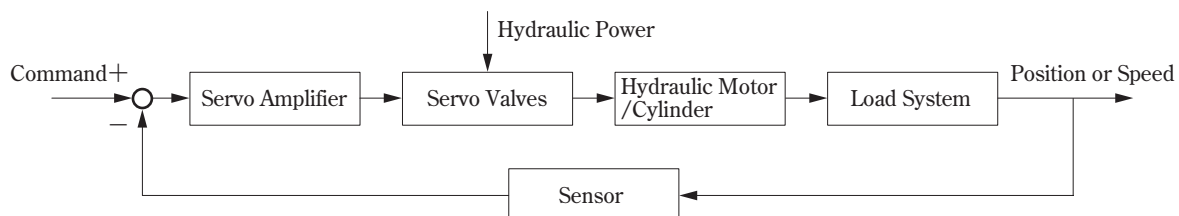

Fig. 9.1 Servo System Configuration

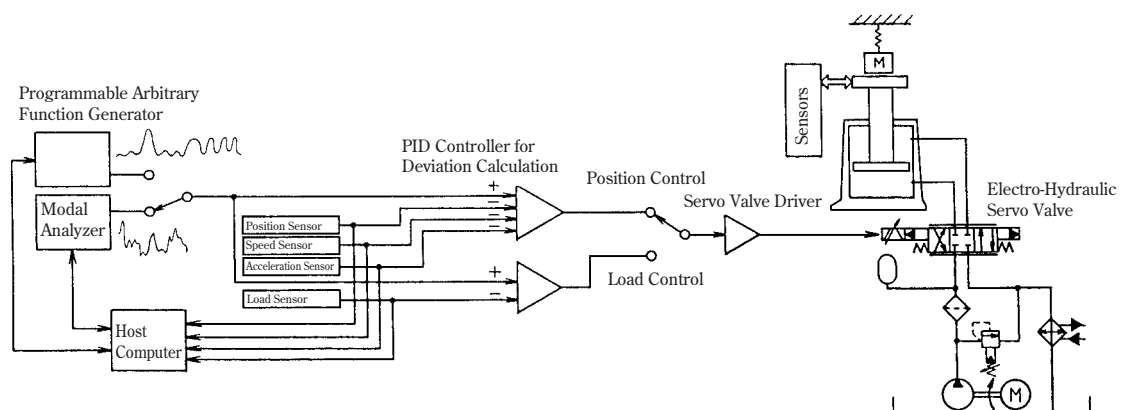

Fig. 9.2 Application to High-Speed Vibration Test Machine

There are two types of electro-hydraulic servo valves: the pilot operated type, which drives a torque motor to amplify the hydraulic power with a nozzle flapper mechanism, and the direct type, which directly drives a spool with a linear motor and electrically provides feedbacks about the spool position. Mechanical servo valves are also available that have a stylus at one side of the spool to control the flow direction by the mechanical motion of the stylus.

## 9-2 Servo Valve Selection

Using the example of a servo system provided in Fig. 9.3, appropriate selection of a servo system is described below.

Based on data in Fig. 9.3, the load pressure  $P_L$  and the load flow rate  $Q_L$  are calculated as follows:

$$P_L = \frac{F}{A} = \frac{10 \times 10^3}{8.8} \times \frac{1}{100} = 11.4 \text{ MPa (1 653 psi)}$$

$$Q_L = A \cdot v = 8.8 \times 25 \times \frac{60}{1\,000} = 13.2 \text{ L/min (3.49 U.S.GPM)}$$

### 9-2-1 Servo Valve Selection with Rated Load Flow Characteristics

The load flow rate through a servo valves is calculated with a tolerance of  $\pm 10\%$  :

$$13.2 \times 1.1 = 14.7 \text{ (3.84) L/min}$$

From Fig. 9.4, the pump pressure  $P_s$  (=  $P_L$  + valve pressure drop) at a load flow rate of 14.7 L/min is obtained as follows.

Servo Valve Model	Press. Drop	Pump Press.
SVD-F11-9.5	14.7 MPa	11.4+14.7=26.1 MPa
SVD-F11-19	4.5 MPa	11.4+4.5=15.9 MPa
SVD-F11-38	1.5 MPa	11.4+1.5=12.9 MPa

The pump pressure should be approximately 1.5 times the load pressure :

$$11.4 \times 1.5 = 17.1 \text{ MPa (2 480 psi).}$$

The pump pressure closest to this value is 15.9 MPa. Therefore, "SVD-F11-19" is the optimal servo valve.

### 9-2-2 Servo Valve Selection Using Calculations

The rated flow rate  $Q_s$  for a servo valve is expressed as follows :

$$Q_s \geq \frac{Q_L}{\alpha \cdot \sqrt{\frac{P_s - P_L}{7}}} \dots\dots\dots \text{(Equation 1)}$$

$\alpha$  : Tolerance of the flow rate for servo valves (0.9 to 0.95)

The pump pressure  $P_s$  should generally be 1.5 times the load pressure  $P_L$ :

$$Q_s \geq \frac{Q_L}{0.9 \times \sqrt{\frac{1.5 \times 11.4 - 11.4}{7}}} \approx 16 \text{ L/min (4.23 U.S.GPM)}$$

This result suggests that the rated flow rate  $Q_s$  is 19 L/min, and the servo valve "SVD-F11-19" should be selected.

To determine the lower limit of the corrected pump pressure  $P_s$ , Equation 1 is transformed as follows :

$$P_s \geq \left( \frac{13.2}{19 \times 0.9} \right)^2 \times 7 + 11.4 \approx 15.6 \text{ MPa (2 262 psi)}$$

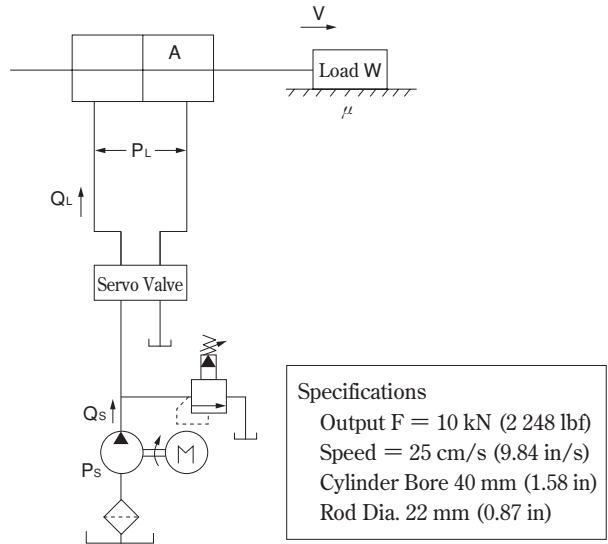

Normally, Output F is calculated with load mass, inertia force and friction force and this value is used.

- $P_s$  : Pump Output Press. MPa (psi)
- $P_L$  : Load Press. MPa (psi)
- $Q_s$  : 10 Pump Output Flow Rate L/min (U.S.GPM)
- $Q_L$  : Load Flow Rate L/min (U.S.GPM)
- $A$  : Cylinder Effective Area  $\text{cm}^2$  [8.8  $\text{cm}^2$  (1.36  $\text{in}^2$ )]

Fig. 9.3 Example of a Servo System

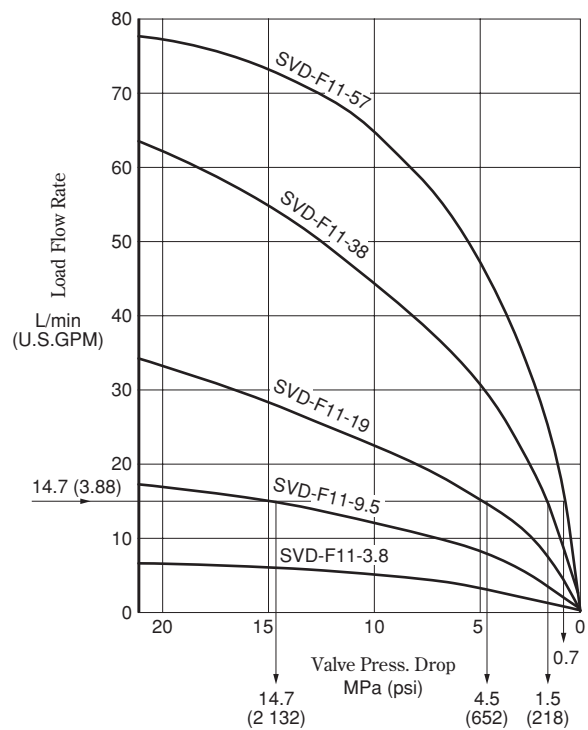

Load Flow Tolerance :  $\pm 10\%$

Fig. 9.4 Load Flow Rate



### 9-3 Electro-Hydraulic Two-Stage Servo Valves

Nearly all types of servo valves are based on common principles. Electro-hydraulic two-stage servo valves generally operate with force feedback. Given that valve pressure drop is constant, the valves control the output flow in proportion to the input signal. Therefore, they can be used to drive a hydraulic cylinder or motor at a speed proportional to the input current.

Figure 9.5 provides illustrations of an electro-hydraulic servo valve. The valve contains identical torque motors in parallel, which serve as a nozzle flapper amplifier with movable coils and nozzles. Coil displacement always determines the spool position. To ensure reliable pilot operation, the valve is provided with a filter prior to the pilot line, as well as a high-performance line filter prior to the valve inlet. Table 9.1 shows valve specifications, and Fig. 9.6 provides frequency response variations.

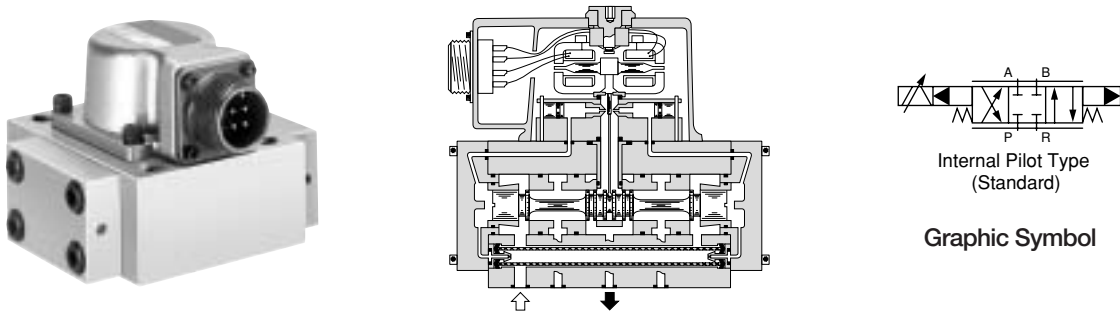

Fig. 9.5 Electro-Hydraulic Servo Valve

Table 9.1 Specifications

Model	SVD-F11
Rated Flow L/min (U.S.GPM) (@ $\Delta P=7$ MPa)	3.8, 9.5, 19, 38, 57 (1.00, 2.51, 5.02, 10.04, 15.06)
Supply Press. Range MPa (psi)	1.4~21 (203~3 046)
Max. Supply Press. MPa (psi)	31.5 (4 569)
Max. Return Press. MPa (psi)	21 (3 046)
Frequency Response Hz (Amplitude: $\pm 100\%$ , Supply Press.: $P_s=21$ MPa) (19 L/min, Phase Delay: $90^\circ$ )	120
Hysteresis	3 % or Less
Threshold	0.5 % or Less
Pressure Gain	30 % or More of Supply Press./1 % of Rated Current
Rated Current , Coil Resistance (in Series)	7.5 mA : 206 $\Omega$ , 20 mA : 80 $\Omega$ (57 L/min (15.1 U.S.GPM))
Internal Leakage ( $P_s=21$ MPa (3 046 psi)) L/min (U.S.GPM)	1.2 or Less (.32) : 3.8 L/min (1.00 U.S.GPM) 1.5 or Less (.40) : 9.5 L/min (2.51 U.S.GPM) 2.3 or Less (.61) : 19~57 L/min (5.02~15.06 U.S.GPM)
Null Shift Due to Temperature Change	2 % or Less with Change of $56^\circ\text{C}$ ( $133^\circ\text{F}$ )
Null Shift Due to Supply Pressure Change	2 % or Less with Change of 80 to 110 %
Null Shift Due to Return Pressure Change	2 % or Less with Change of 0 to 20 %
Ambient Temperature	$-40\sim+135^\circ\text{C}$ ( $-40\sim275^\circ\text{F}$ )
Applicable Fluid	Petroleum-Based, Fatty Acid Ester

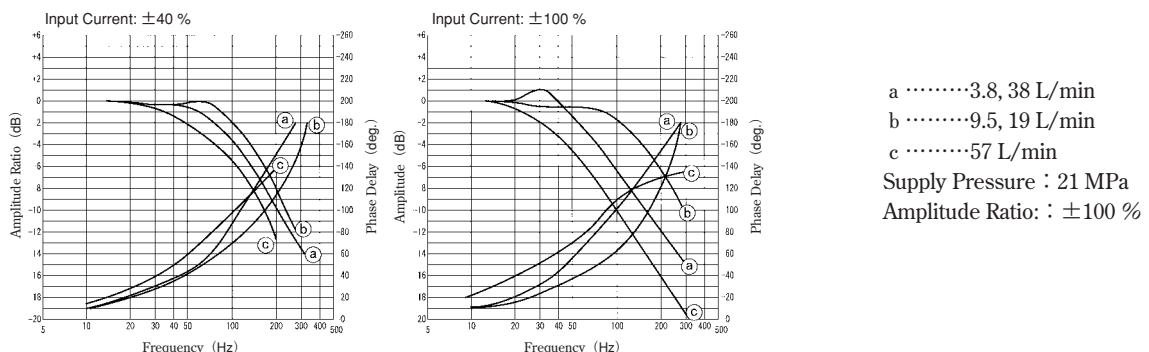
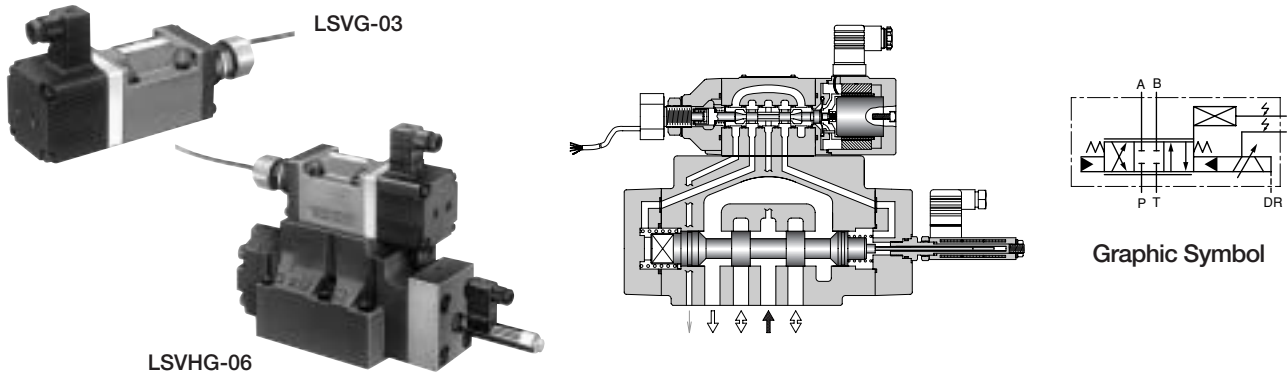

Fig. 9.6 Frequency Response

## 9-4 Direct Drive Servo Valves

The valves directly drive a spool with a small and high-power linear motor. Direct drive servo valves electrically send the spool position data to the controller to provide quick response and high contamination resistance. These valves are available in two types: direct spool control and pilot operation (a combination of small valves).

Figure 9.7 shows illustrations of direct drive servo valves. Table 9.2 and Figures 9.8 and 9.9 give the specifications, flow rate characteristics, and frequency response of typical direct drive servo valves.

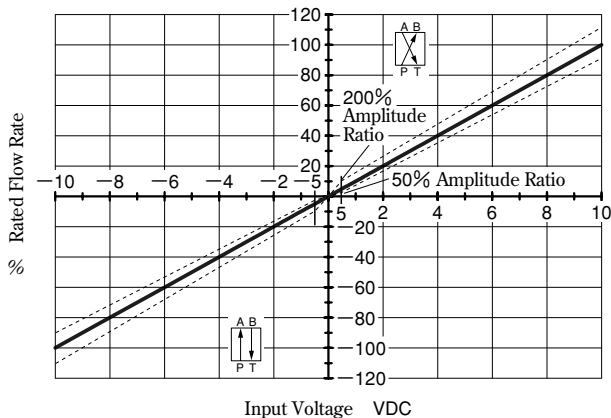

**Fig. 9.7 Direct Drive Servo Valve**

**Table 9.2 Specifications**

Model	LSVG-03-60	LSVHG-04-750	LSVHG-06-900	LSVHG-10-1500
Rated Flow L/min(U.S.GPM) (@ $\Delta P=7$ MPa)	60 (15.9)	750 (198)	900 (238)	1 500 (396)
Max. Operating Press. MPa (psi)	35 (5 076)	35 (5 076)	35 (5 076)	31.5 (4 569)
Max. Return Press. MPa (psi) External Drain	35 (5 076)	31.5 (4 569)	35 (5 076)	21 (3 046)
Internal Drain	35 (5 076)	31.5 (4 569)	35 (5 076)	21 (3 046)
Allowable Back Press., Drain Port MPa (psi)	0.05 (7.25)			
Frequency Characteristics Hz (Amplitude: $\pm 25\%$ , Phase Delay: $-90^\circ$ )	350	100	100	100
Step Response ms ( $0 \leftrightarrow 100\%$ )	3	8	8	8
Linear Motor Specifications Current	2A (MAX. 6A)			
Coil Resistance	4.5 $\Omega$ (@20°C)			
Internal Leakage (Supply Press. Ps=14 MPa, Pilot Press. Pp=14 MPa) <sup>1)</sup>	—	Spool Type "2": 5 L/min (1.32 U.S.GPM) or Less Spool Type "4": 6.5 L/min (1.71 U.S.GPM) or Less Spool Type "2P": 12 L/min (3.17 U.S.GPM) or Less		
Vibration Resistance	Frequency: 10~60 Hz, Amplitude: 4 mm, Acceleration: 7.8~282 m/s <sup>2</sup> Frequency: 61~2 000 Hz, Amplitude: 4~0.0038 mm, Acceleration: 294 m/s <sup>2</sup>			
Waterproof	IP64 compatible			
Ambient Temperature	-15~+60°C (5~140 °F)			

Note 1) The amount of the leakage is the total of leakage from the main spool and the pilot spool.



**Fig. 9.8 Input Signal vs. Flow Rate**

(Viscosity: 30 mm<sup>2</sup>/s, Valve Pressure Difference: 7 MPa)

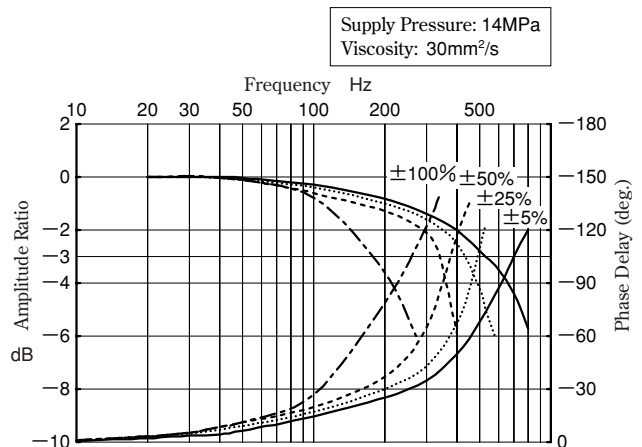





**Fig. 9.9 Frequency Response (LSVG-03)**

## 9-5 Servo Amplifiers

Servo amplifiers drive servo valves, based on the same principles as the amplifiers for proportional electro-hydraulic control. Table 9.3 lists the functions and features of the servo amplifiers and related devices. Fig. 9.10 and Table 9.4 give a circuit example and specifications, respectively.

**Table 9.3 Functions and Features of Servo Amplifiers**

Name, Model, and Appearance	Function and Characteristics
<p>Linear Servo Amplifier AMLS-※-※-10</p> 	<p>For high-speed linear servo valves only. The amplifier determines the spool position to control the valves from the input command signal and the spool position sensor output.</p>
<p>Servo Controller SK1056-※-※-20</p> 	<p>An analog controller that provides all amplifier functions required in a servo system. The controller displays feedback signals, opens/closes the valves from external signals, and outputs alarm signals.</p>
<p>Digital Positioning Servo Controller SK1088-20</p> 	<p>A servo controller using digital signals. With a servo amplifier embedded, the controller sends multifunction commands by pulse train input or serial communication (RS-232C) and receives position feedbacks by incremental pulse input.</p>
<p>Servo Amplifier AMS-※-S-20</p> 	<p>This amplifier is the two-input signal type (voltage input), although it has auxiliary input (AUX) for minor loop construction. It can supply a constant voltage of <math>\pm 12\text{ V}</math> externally; therefore, it can be easily connected to a setting adjuster or a sensor (potentiometer, etc.).</p>
<p>Amplifier for Linear Variable Differential Transformers AMD-LA-S-※-3712</p> 	<p>This amplifier is used for linear variable differential transformers of SVY-F3 and -F31 electro-hydraulic three-stage servo valves.</p>

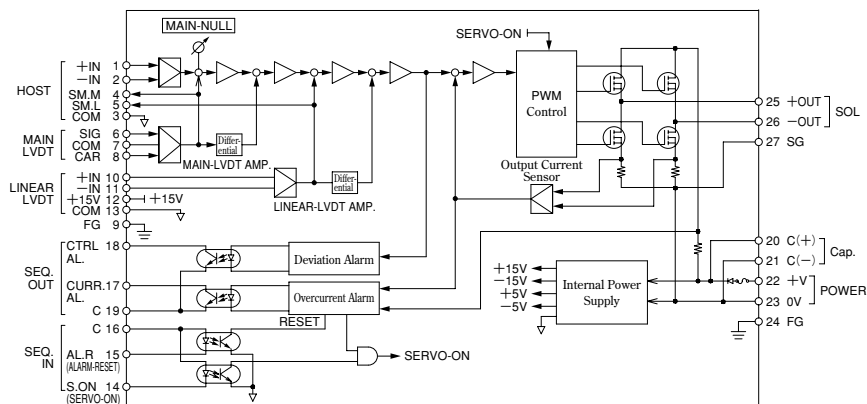

**Fig. 9.10 Example of a linear servo amplifier**

Table 9.4 Specifications of Linear Servo Amplifier

Item	Model Numbers	AMLS- *-D48-10	AMLS- *-D24-10													
Max. Input Voltage		±10V														
Max. Output Current		±4A	±3A													
Power Supply		DC+48V±5% 4A	DC+24V±5% 3A													
Control Signal Input/Output		<ul style="list-style-type: none"> <li>· Servo-On Input  Photo Coupler Input Input Resistance: 2.2kΩ</li> <li>· Alarm Reset Input  Operating Voltage: +15~+28V</li> <li>· Overcurrent Alarm (CURR. AL.) Output  Photo Coupler Output Voltage: Max. DC 50 V</li> <li>· Deviation Alarm (CTRL. AL.) Output  Current: Max. 30 mA</li> </ul>														
Sensor Monitor Signal Output		<table border="1" style="width: 100%; border-collapse: collapse;"> <thead> <tr> <th>Linear Servo Valves</th> <th>Model Numbers</th> <th>Monitoring Spool Position</th> </tr> </thead> <tbody> <tr> <td rowspan="2">LSVG</td> <td>AMLS-A- *-10</td> <td>SM.L-COM</td> </tr> <tr> <td>AMLS-B- *-10</td> <td></td> </tr> <tr> <td rowspan="2">LSVHG (Pilot operation type)</td> <td>AMLS-C- *-10</td> <td>SM.L-COM (Pilot operated valves)</td> </tr> <tr> <td>AMLS-D- *-10</td> <td>SM.M-COM (Main valves)</td> </tr> </tbody> </table> <p>The output value of a sensor monitor is ± 2.5V</p>		Linear Servo Valves	Model Numbers	Monitoring Spool Position	LSVG	AMLS-A- *-10	SM.L-COM	AMLS-B- *-10		LSVHG (Pilot operation type)	AMLS-C- *-10	SM.L-COM (Pilot operated valves)	AMLS-D- *-10	SM.M-COM (Main valves)
Linear Servo Valves	Model Numbers	Monitoring Spool Position														
LSVG	AMLS-A- *-10	SM.L-COM														
	AMLS-B- *-10															
LSVHG (Pilot operation type)	AMLS-C- *-10	SM.L-COM (Pilot operated valves)														
	AMLS-D- *-10	SM.M-COM (Main valves)														
Ambient Temperature		0~50°C (32~122 °F)														
Ambient Humidity		20~90%Rh (No condensation)														
Mass		Approximately 1.8 kg (3.97 lbs)														

9-6 Sensors

Servo systems operate according to various control parameters, including position, angle, speed, acceleration, pressure, flow rate, load, and torque. Position sensors, including potentiometers, synchronization generators, magnetic scales, and optical equipment (pulse encoder, digital position sensor, etc.), can accurately detect the component positions. Fig. 9.11 shows examples of the position sensors.



Potentiometer

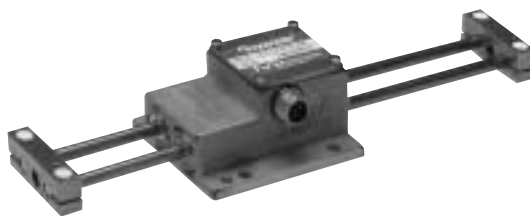

Magnetic Sensor

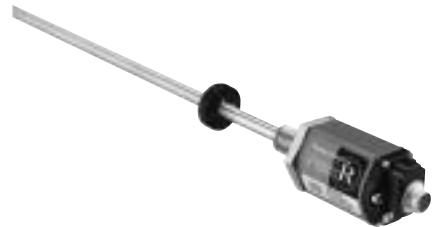

Magnetostrictive Sensor

Fig. 9.11 Position Sensors

9-7 Hydraulic Power Source

A hydraulic power source is required to provide constant hydraulic power for servo valve operation, and is incorporated in hydraulic circuits as shown in Fig. 9.12. Servo systems allow circuits comparable to general hydraulic circuits. However, careful consideration must be given to contaminant removal from the working fluid. Generally, 95 % of failures of servo valves, which are precisely sized, are caused by contaminants in the working fluid. To prevent valve malfunction and spool edge wear due to clogging, 5 to 10µm filters should be installed in the systems. It is recommended that the systems operate with a fluid contamination level of NAS 1638 class 7; systems using direct drive servo valves, where a motor directly drives a spool, should operate with a fluid contamination level of NAS 1638 class 10. Also, strict control of the fluid temperature is required for the servo systems; temperature fluctuations must be within 10 to 20 °C (50~68 °F).

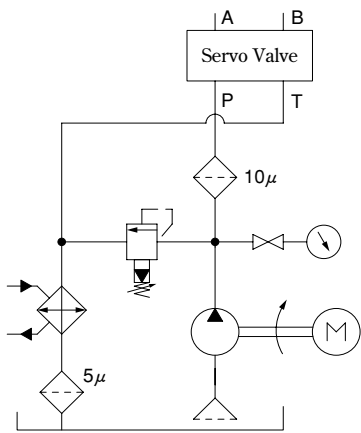

Hydraulic Circuit with a Fixed Displacement Pump

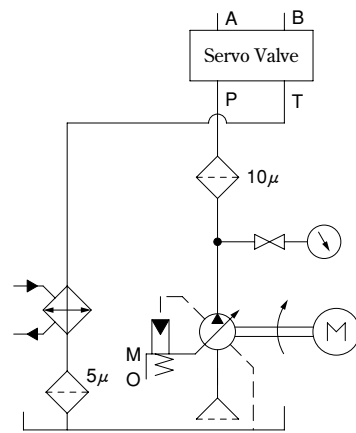

Hydraulic Circuit with a Variable Displacement Pump

Fig. 9.12 Hydraulic Power Source

### 9-8 Servo Systems with Pump Speed Control

Simple servo systems, which do not use hydraulic servo valves or high-speed proportional valves, can be made by controlling the pump rotation speed with a servo motor. Fig. 9.13 shows an example of a simple servo system with pump speed control (IH servo drive pack). The IH servo drive pack is a compact and energy-saving hydraulic power source consisting of an AC servo motor, piston pump, reservoir, and closed hydraulic control circuit. This unit controls the pump discharge and pressure by adjusting the pump rotation speed. It can be combined with a sensor-equipped cylinder and a dedicated controller to facilitate the configuration of a position, speed, and pressure control system.

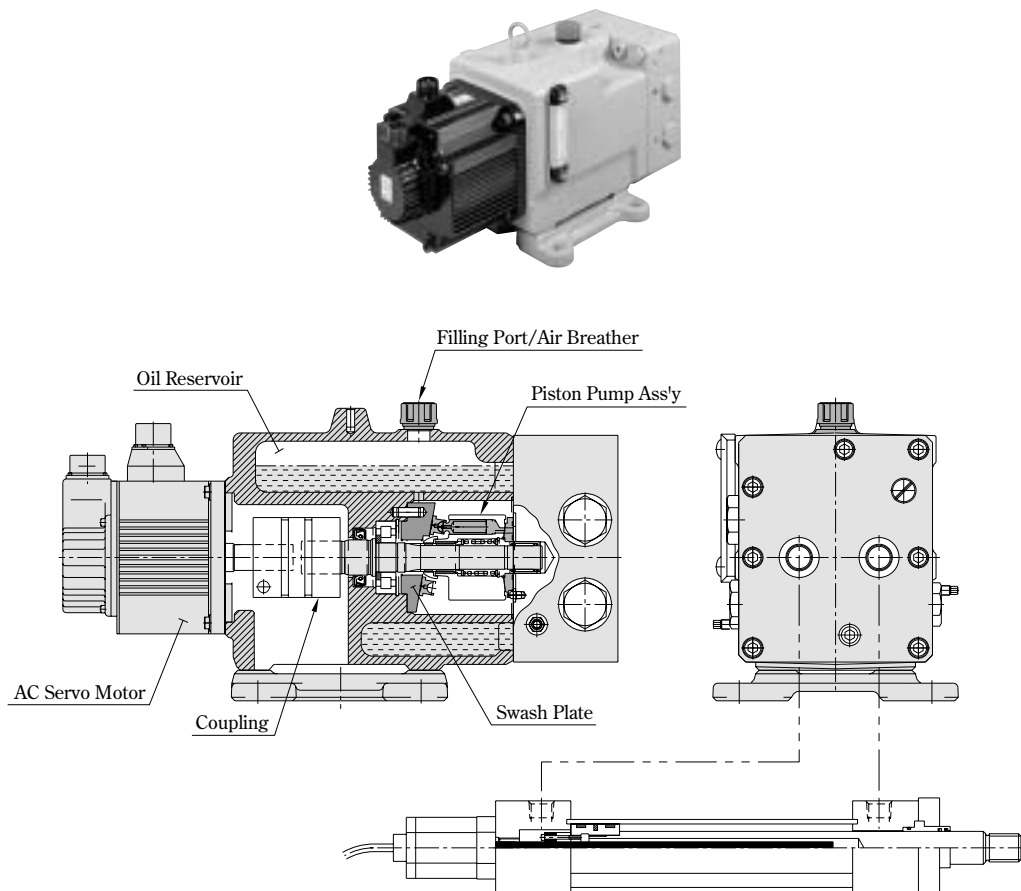

Fig. 9.13 IH servo drive pack

### 9-8-1 Description of IH Servo Drive Pack

The IH servo drive pack drives the pump with an AC servo motor, and the pump supplies pressured oil bi-directionally. This results in a simple hydraulic control system where the load cylinder is simply connected to both outlet ports without control valves. The pump draws oil by using the self priming valve to compensate oil in

the cylinder.

The deviation of the control signals and sensor signals from the host is sent to the servo driver to drive the AC servo motor, consequently forming a feedback loop. The sensor signals come from the position sensor on the cylinder and the pressure sensor on the servo drive pack.

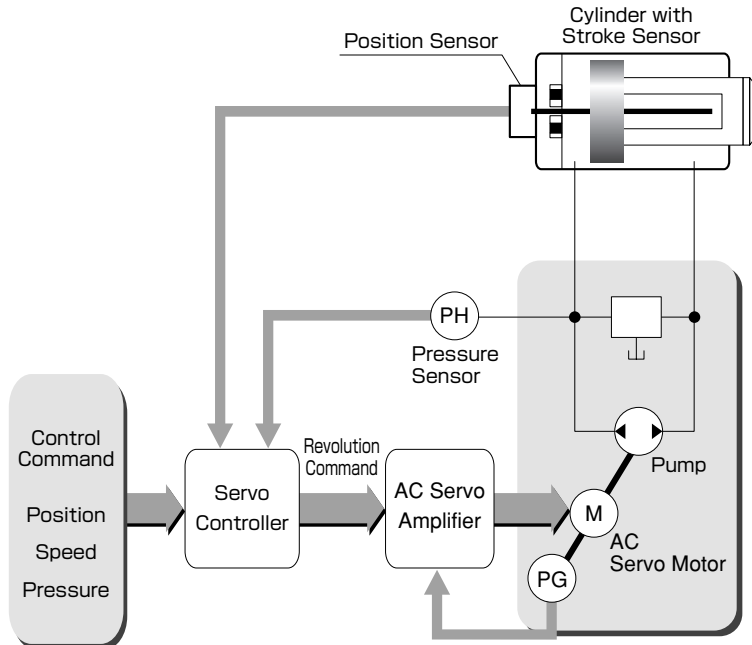

Fig. 9.14 IH Servo Drive Pack

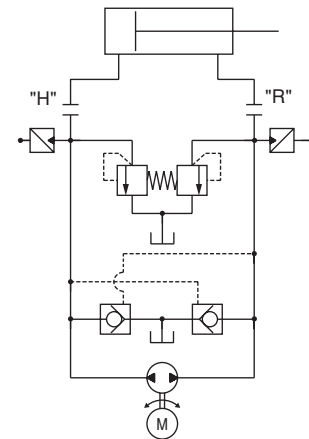

Fig. 9.15 Hydraulic Circuit

### 9-8-2 Energy Saving Hydraulic System with Rotational Frequency Control

Conventional servo systems using servo valves generally operate with hydraulic power sources that produce excess load flow and pressure. Therefore, such systems involve heat and power loss caused by excess flow, as well as considerable pressure loss through the valves. On the other hand, systems with rotational frequency control

regulate the motor speed so that the flow rate and pressure are optimized for load requirements. Systems with rotation control can minimize pressure loss and greatly reduce the power consumption for pressure holding.

Table 9.5 shows the specifications of the IH servo drive pack.

Table 9.5 Specifications of IH Servo Drive Pack

Model Numbers	Pump Displacement cm <sup>3</sup> /rev (cu. in./rev)	Max. Rev. Speed r/min	Estimated Cylinder Thrust/Size	Reservoir Capacity cm <sup>3</sup> (cu. in.)	Max. Oil Volume Difference cm <sup>3</sup> (cu. in.)
YSD1-※-09 YSD1-※-13	6, 10 (0.37~0.61)	2 000★	20~30 kN (4 497~6 744 lbf) (Cylinder Bore: φ 63)	2 500 (153)	1 500 (92)
YSD2-※-18 YSD2-※-29 YSD2-※-44	6, 10, 16 (0.37, 0.61, 0.98)		50~60 kN (11 240~13 488 lbf) (Cylinder Bore: φ 80)	4 200 (256)	2 500 (153)
YSD3-※-55 YSD3-※-75	10, 16, 30 (0.61, 0.98, 1.83)		100 kN (22 480 lbf) (Cylinder Bore: φ 100)	5 800 (354)	3 500 (214)

★The maximum revolution speed may be subject to the operating pressure and the motor output.

### 9-8-3 Applications

#### ●Positioning

Cutting machines, grinders, large valve opening/closing units, damper controls, bulge forming, presses, caulking machines, metal bellows expansion units, large cargo transport equipment, pipe benders, sluice gate opening/closing equipment

#### ●Pressure Control

Presses, loading test apparatuses, molding machines, steel ball processing machines, bender boosters, pressure welding machines, friction welding machines

## Energy Converters

### ●Torque Motor

A rotary motor for electro-mechanical energy conversion, which is used in the input stage of the servo valves.

### ●Linear Motor

A motor that directly converts electric energy to power for linear motion. Because of its high efficiency, this motor is used for ultra high-speed train which is currently under development.

### ●AC Servo Motor

This motor amplifies power according to an input signal and drives the main shaft of a machine tool as commanded. Compared to the DC servo motor, this motor is compact and maintenance-free, making it the motor of choice for many control units.

### ●Nozzle Flapper

A mechanism consisting of a nozzle, flapper, and orifice, as shown in Fig. 9.16, to control the fluid pressure according to the mechanical displacement. When a mechanical displacement force is applied to the flapper, the relative position between the nozzle and the flapper shifts, and the area between them changes. As a result, pressure change between the nozzle and the orifice, or the nozzle back pressure, serves as the output pressure. This conversion mechanism has the advantage of being able to deliver a relatively high pressure while applying only a small force to the flapper. To operate a system with a higher pressure, another nozzle should be installed at the other side of the flapper for control based on pressure differences.

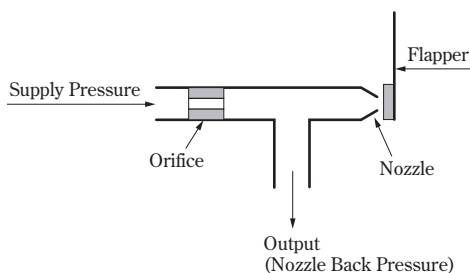

Fig. 9.16 Nozzle Flapper Mechanism

### ●Flapper

A plate element used to open/close the nozzle in the nozzle flapper mechanism.

## Characteristics

### ●Hysteresis

Deviation of the input current required to achieve the same flow rate for each cycle of continuous operation (at a speed that does not affect dynamic performance). It is expressed in percent (%) of rated current.

### ●Resolution

Minimum increase/decrease in the input current required to increase/decrease the control flow. It is expressed in percent (%) of the rated flow rate.

### ●Threshold

Change of the signal input required to reverse the valve output in the null position. It is expressed in percent (%) of the rated signal output.

### ●Dither

Vibration with a relatively high frequency that is applied to spool valves to minimize effects of friction and hydraulic lock and improve the resolution and hysteresis.

### ●Gain

Also called pressure/flow gain. It is a ratio between changes in input and output signals.

### ●Pressure Gain

Ratio of an output (load pressure) change to an input (current or displacement) change at a constant load flow.

### ●Flow Gain

Ratio of an output signal (flow rate) change to an input signal (flow rate) change.

### ●Drift

Shift of the zero point of an element or system, or an output independent of an input. A drift causes steady-state deviations; it should be minimized in an operational amplifier, using a drift compensation circuit.

### ●Frequency Response

Change in a frequency amplitude ratio or phase delay between input and output signals, observed in a steady state where the input signal varies in a sine-wave form.

## General

### ●Analog Signal

Continuous representation of signals.

### ●Digital Signal

Discrete representation of signals.



# 10

# ACTUATORS

The actuators convert hydraulic energy to mechanical energy and are grouped as follows.

- 10-1 Hydraulic Cylinders
- 10-2 Hydraulic Motors
- 10-3 Oscillating Motors

## 10-1 Hydraulic Cylinders

Cylinders include linear motion actuators, such as double acting, single acting, and telescopic cylinders.

### 10-1-1 Types of Cylinders

#### (1) Double Acting Cylinder

This is a standard cylinder that produces reciprocating motion. It is available in single and double rod types. Fig. 10.1 shows the single rod cylinder. This cylinder is provided with a cushion mechanism, which uses a cushion sleeve to close the fluid return port as the piston rod retracts. Therefore, the fluid is discharged through a restrictor located in parallel with the return port, resulting in a higher piston back pressure and a slower piston speed.

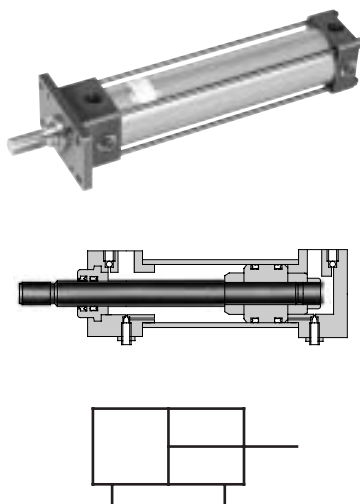

Graphic Symbol

Fig. 10.1 Double Acting Cylinder

#### (2) Single Acting Cylinder (Ram Cylinder)

This is a cylinder that pushes the piston in one way (extending direction). The piston rod is returned by gravitation or a mechanical force.

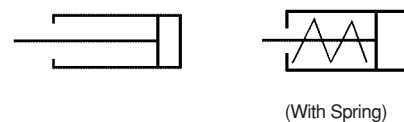

Fig. 10.2 Graphic symbol

#### (3) Telescopic Cylinder

This cylinder uses a multistage tube as a piston rod to obtain a long stroke. It is useful for pistons requiring a more compact housing. Single and double acting types are available.

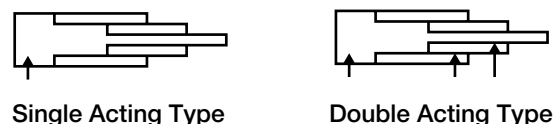

Fig. 10.3 Telescopic Cylinder

### 10-1-2 Considerations on Cylinder Selection

#### (1) Models (JIS B 8367: 1999 Mounting dimensions for hydraulic cylinders)

- ①7HT: For 7 MPa (1 015 psi), Rectangular Cover, Tie-rod
- ②10HS: For 10 MPa (1 450 psi), Built-in Cylinder
- ③10HT: For 10 MPa (1 450 psi), Rectangular Cover, Tie-rod
- ④14HT: For 14 MPa (2 031 psi), Rectangular Cover, Tie-rod
- ⑤16HT: For 16 MPa (2 320 psi), Rectangular Cover, Tie-rod
- ⑥16HR: For 16 MPa (2 320 psi), Round Cover, Flange-Welding or Screw-In

⑦21HT: For 21 MPa (3 046 psi), Rectangular Cover, Tie-rod

⑧25HR: For 25 MPa (3 626 psi), Round Cover, Flange-Welding

### (2) Cylinder Speed

Generally, a cylinder speed of 15 to 300 mm/s (.59~11.8 in/s) is recommended. An excessively high or low speed leads to rapid packing wear, causing fluid leakage from the rod seal or internal leakage. When the cylinder speed is too low, a stick-slip phenomenon may affect smooth cylinder operation. Special caution must be paid to the packing and the sliding parts when operating the cylinder beyond the recommended speed range.

### (3) Cylinder Mounting

The cylinders can be mounted as shown in Table 10.1. They should be mounted so that the pressure is always applied in the moving direction with the minimum radial load, depending on the load characteristics and cylinder motion.

### (4) Cylinder Bore and Rod Bore

Table 10.2 lists rod bores corresponding to cylinder bores. The rods are classified according to the area ratio between the head and rod sides.

### (5) Rod Buckling

When a rod is subject to tensile stress, only its tensile strength need be considered. On the other hand, a long rod subject to a compression force may bend and easily break with a small stress. This phenomenon is called buckling, and the buckling strength of the rod must be determined, based on the load, rod bore, the rod-end coefficient (depending on the cylinder mounting type), and rod length. The buckling strength is an essential factor in determining the maximum stroke length. The safety factor is normally set at 4.

### (6) Minimum Operating Pressure

The operating pressure is defined as follows: 0.5 MPa (72.5 psi) or less for U-packing, X-rings, O-rings (JIS B 2401), and combination seals (S), and 0.25 MPa (36.3 psi) or less for piston rings. Standard cylinders operate with 0.3 MPa (43.5 psi) of the working pressure.

### (7) Cushion

The piston in a cylinder, which moves in the reciprocating motion, contacts the cover at the stroke end to produce shocks. To minimize the shocks, the cylinder should be provided with a cushion mechanism to reduce the piston speed at the stroke end. However, the cushion mechanism generates a higher internal pressure as inertial force increases.

### (8) Packing Materials and Hydraulic Fluids

- i. Nitrile rubber (NBR):  
Standard fluids and other than phosphate ester
- ii. Hydrogenated rubber (HNBR):  
High-temperature fluids
- iii. Polytetrafluorethylene (PTFE):  
High-temperature fluids
- iv. Fluorinated rubber: Phosphate ester

Table 10.1 Mounting types

Types	Names	Illustration of Mounting types
SD	None	
LA	Foot Mounting Side Lugs	
LB	Foot Mounting Side End Angles	
FA	Rod Rectangular Flange	
FB	Head Rectangular Flange	
CA	Head Detachable Eye	
CB	Head Detachable Clevis	
TA	Rod Trunnion	
TC	Intermediate Trunnion	

Table 10.2 Cylinder Bore and Rod Bore (JIS B 8367)

	Cylinder Bore	Rod Bore		
		Type A	Type B	Type C
mm (in)	32 (1.26)	22 (.87)	18 (.71)	14 (.55)
	40 (1.57)	28 (1.10)	22 (.87)	16 (.63)
	50 (1.97)	36 (1.42)	28 (1.10)	22 (.87)
	63 (2.48)	45 (1.77)	36 (1.42)	28 (1.10)
	80 (3.15)	56 (2.20)	45 (1.77)	36 (1.42)
	100 (3.94)	70 (2.76)	56 (2.20)	45 (1.77)
	125 (4.92)	90 (3.54)	70 (2.76)	56 (2.20)
	140 (5.51)	100 (3.93)	80 (3.15)	63 (2.48)
	160 (6.30)	110 (4.33)	90 (3.54)	70 (2.76)
	180 (7.09)	125 (4.92)	100 (3.93)	80 (3.15)
Ratio	200 (7.87)	140 (5.51)	110 (4.33)	90 (3.54)
	220 (8.66)	160 (6.30)	125 (4.92)	100 (3.93)
	250 (9.84)	180 (7.09)	140 (5.51)	110 (4.33)
	1	1/2	1/1.5	1/1.25

## 10-2 Hydraulic Motors

Hydraulic motors convert hydraulic power to mechanical rotating force. Their rotation speed can be steplessly adjusted by controlling the supply flow, while their output torque depends on the difference between the motor inlet and outlet pressures. The motors are available in gear, vane, and piston types, as are the hydraulic pumps. Piston motors with variable displacement are also available.

### 10-2-1 Gear Motors

- (1) External type: This motor is simple, compact, lightweight, inexpensive, and capable of relatively high-speed rotation. It has a cross-sectional structure similar to that of gear pumps. It requires a drain to be installed for oil seal protection.
- (2) Internal type: This motor is compact and relatively inexpensive, and operates with a high torque at a low speed. It consists of an internal trochoid gear motor and a differential speed reducer. Fig. 10.4 shows the cross section of this motor.

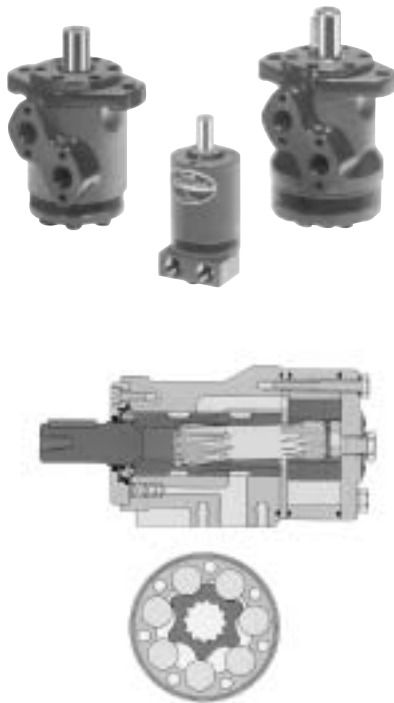

Fig. 10.4 Internal Gear Motor (with differential speed reducer)

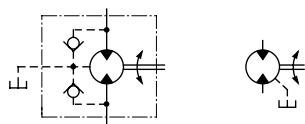
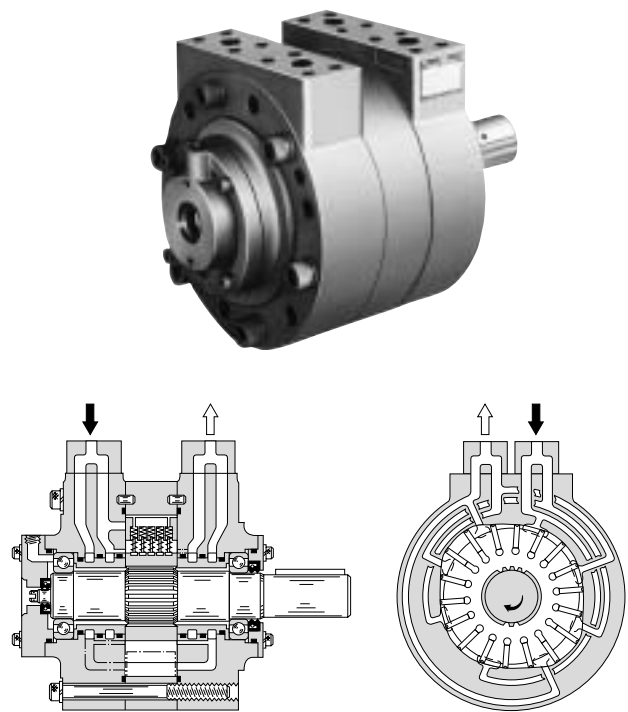

Fig. 10.5 Graphic Symbol

### 10-2-2 Vane Motors

- (1) Low-speed high-torque vane motor: This motor has a relatively large capacity and operates with a high torque at a low speed. The motor shown in Fig. 10.6 has four motor chambers and can change the torque control mode to 1/3 and 2/3.
- (2) Medium-speed vane motor: This motor has a structure similar to that of the pressure-balanced vane pump, the capacity of which is relatively small. It is provided with a vane lift mechanism (spring) to ensure that contact between the vane and the cam ring is always maintained from the time of the motor starts.



Full torque

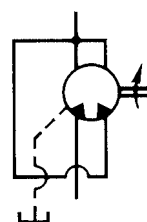

2/3 Torque

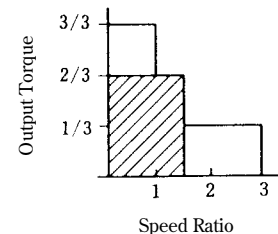

Fig. 10.6 Low-Speed High-Torque Vane Motor

### 10-2-3 Piston Motors

Piston motors are available in axial and radial types. Also available are fixed and variable displacement axial piston motors that operate at a high, medium, or low speed with a bent axis or swash plate. The axial piston motor has a higher volumetric efficiency than other types of motors. Radial piston motors generally operate with a high torque at a low speed.

- (1) Bent axis fixed displacement piston motor: This motor is based on the same structural principles as the bent axis fixed displacement piston pump. Variable displacement type is also available. The motor can have a bent-axis angle of up to 40 degrees and is generally suitable for high-speed operation.
- (2) Swash plate type piston motor: The high-speed type of this piston motor is based on a structure similar to that of the fixed displacement swash plate type pump. Fig. 10.7 shows an example of the low-/medium-speed type. Its cylinder block has two pistons and swash plates facing each other. It provides good low-speed performance at a time of the motor starts.

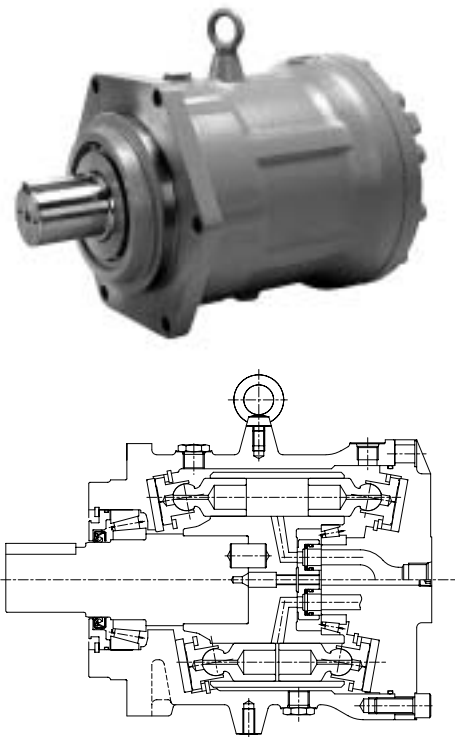

Fig. 10.7 Opposed Swash Plate Type Piston Motor

- (3) Eccentric radial piston motor: This motor is widely known as the star-shaped motor. It has several fixed cylinders perpendicularly placed on the output shaft in a radial pattern. The flow is fed or discharged to/from the cylinders through a distributor valve connected to the shaft with a swivel joint. When a hydraulic pressure is applied to the piston, it reciprocates and pushes the eccentric cam on the shaft to produce torque. This motor is designed for low-speed high-torque applications.

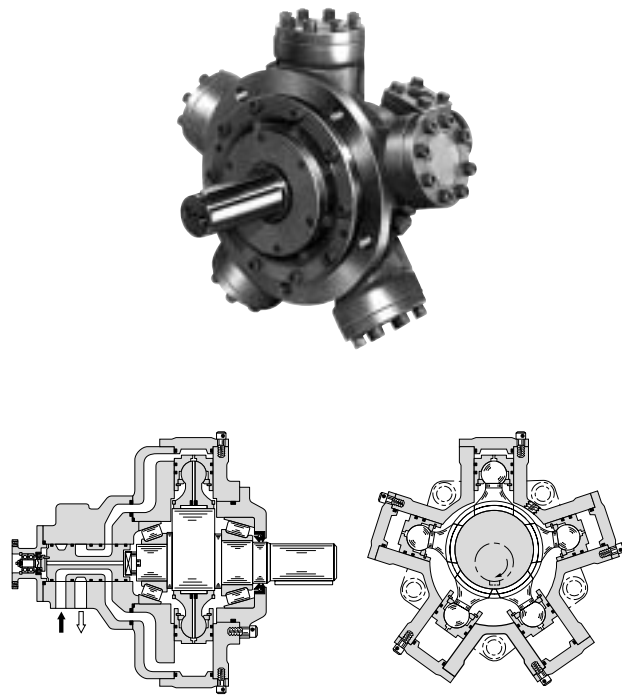

Fig. 10.8 Radial Piston Motor

- (4) Multi stroke radial piston motor: This motor has a piston placed in the direction of the radius of the shaft with a cam roller. The piston moves on the patterned cam ring to produce torque. This motor can offer a larger displacement capacity than that of any other hydraulic motors. It is often used in winches and crushing machines.

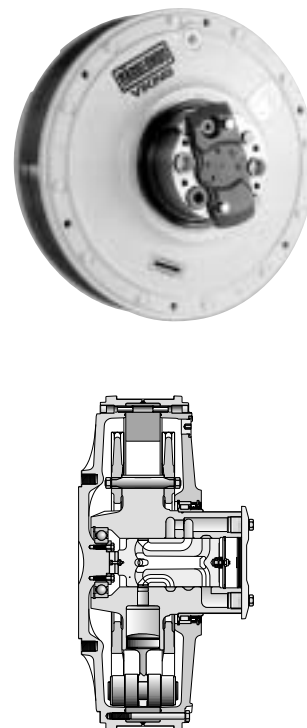
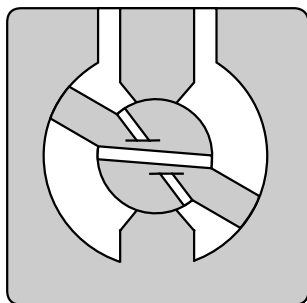

Fig. 10.9 Multi Stroke Radial Piston Motor

### 10-3 Oscillating Motors

Oscillating motors are actuators that generate rotation at a certain angle with a hydraulic pressure. They include the vane and piston types. They can be easily mounted because they do not require a link mechanism. Also, these motors are compact and provide a high torque.

- (1) Vane type oscillating motor: single vane and double vane types are available. The single vane type operates with a rotation angle of 280 degrees or less, while the double operates with 100 degrees or less, giving the torque twice what the single can produce. Compared to the piston motors, the vane type oscillating motors have simple structures and provide high response. Due caution should be paid to internal leakage inherent in the motor design. Fig. 10.10 shows the vane type oscillating motor.
- (2) Piston type oscillating motor: The rack and pinion type and helical spline type are available. Fig. 10.11 shows the rack and pinion type, which uses an opposed single acting cylinder to drive the rack for pinion rotation. Fig. 10.12 shows the helical spline type, which has a piston with a screw mechanism to rotate the shaft. Piston oscillating motors allow the oscillation angle to be adjusted with the cylinder stroke length; therefore, careful consideration of the oscillating angle is not required. They also have very little internal leakage.



Double Vane Type

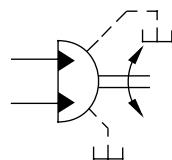

Graphic Symbol

Fig. 10.10 Vane Type Oscillating Motor

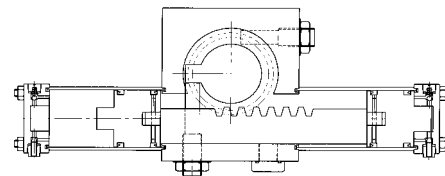

Fig. 10.11 Rack and Pinion Type Oscillating Actuator

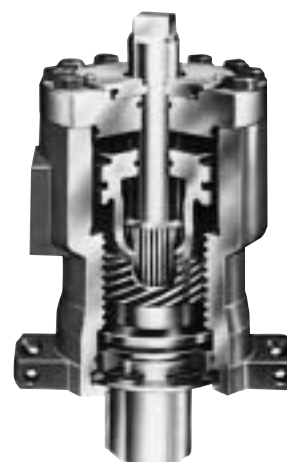

Fig. 10.12 Helical Spline Type Oscillating Actuator

# 11

# HYDRAULIC ACCESSORIES

## Accessories

- 11-1 Filters
- 11-2 Accumulators
- 11-3 Heat Exchangers
- 11-4 Measuring Instruments
- 11-5 Valves
- 11-6 Others

## 11-1 Filters

Hydraulic systems may malfunction due to clogging and internal wear. With hydraulic fluids contaminated, hydraulic systems are damaged and fail to provide optimal performance. Therefore, they require filtration to remove contaminants from the working fluids.

Filtration is rated by either of two methods: absolute, based on the multi-pass test, or nominal, indicated by filter suppliers. The absolute filtration rating should be given a higher priority than the normal.

Filter types are defined by JIS B 8356: 1993.

1. Reservoir filters (FT, FS)
2. Line filters (FL)
3. Off-line filters
4. Other cleaning equipment

### 11-1-1 Reservoir Filters

Two types are available. One protects the pump by installing filters at the pump suction port. The other, called the return filter, cleans the working fluid returning to the reservoir.

- (1) Suction filter without a case (FT): It consists of a core rolled up with a filter. This filter equipment is called a strainer and submerged in working fluids for filtration. Typically, it uses a 105- $\mu\text{m}$  mesh filter.



Fig. 11.1

- (2) Suction filter with a case (FS): It has a filter element in a case. One type employs a differential pressure indicator to indicate that the filter element is clogged. Another type is equipped with a by-path valve. Typically, a 105- $\mu\text{m}$  mesh is used as the filter element.

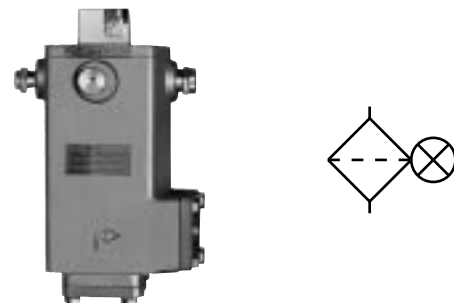

Fig. 11.2

- (3) Return filter: There are two types of the return filters. The tank-top type is installed on the reservoir, and the in-line type is within the lines. The latter type employs a low-pressure line filter.

Figure 11.3 shows the tank-top type.

As shown in Table 11.1, the filtration rating should be decided with consideration given to the filtration conditions.

Table 11.1

Filtration Conditions	Filtration Ratings
1. Installed in a system operating at 7 MPa (1 016 psi) or more	20~35 $\mu\text{m}$
2. Installed in a system operating at 21 MPa (3 046 psi) or more together with a proportional valve	10~20 $\mu\text{m}$
3. Installed together with servo valves	10 $\mu\text{m}$





Tank-Top Filter

Fig. 11.3

### 11-1-2 Line Filters

A reservoir filter with a higher filtration rating results in higher suction resistance. To avoid such a rise of suction resistance, line filters are required.

Line filters protect hydraulic components by removing contaminants from working fluids and keeping them clean. Filter selection generally depends on the working pressure, flow rate, and filtration rating. The filters may be installed with a line connection or a manifold. There are also a line filter type that is equipped with a stop valve, a check valve, a relief valve, and an electric switch.



Threaded Connection Type



Manifold Type

Fig. 11.4

### 11-1-3 Off-Line Filters

These filters clean working fluids in a reservoir by using a dedicated pump and a filter separate from the line. They are employed when a higher cleaning level is required.



Fig. 11.5

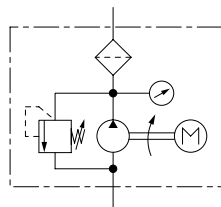

### 11-1-4 Other Cleaning Equipment

- (1) Air breather: An actuator causes the working fluid and air to flow in and out of a reservoir. An air breather serves as ventilation for air intake and discharge, filtering out dust in the air. The air breather is installed on the tank-top. An appropriate air breather should be selected according to the Fire Service Law, if applied.

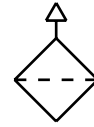

Fig. 11.6

- (2) Oil filling port with an air breather: This filtration tool combines an oil filling port and an air breather.

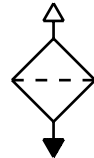

Fig. 11.7

- (3) Oil filling port: A working fluid is supplied through this hole to a reservoir. The hole is equipped with a filter so that no dust is allowed to enter the reservoir.

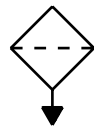

Fig. 11.8

- (4) Magnet separator: The magnet separator keeps a working fluid clean by absorbing iron powders in the reservoir. It is often used in servo systems.



Fig. 11.9



**Usage**

1. Accumulation of energy: Achieving a large flow rate and compensating from internal leakage
2. Absorption of pulsations: Reducing noises and pulsations
3. Absorption of shocks: Used as a shock absorber

**Type**

1. Bladder type: Separates gas from oil by a rubber bladder.
2. Diaphragm type: Sometimes used as a small accumulator.
3. Piston type: Shaped in the form of a cylinder without a rod.
4. Spring type: Often used to prevent pulsations.
5. Weight loaded type: Designed for large-scale machinery and consisting of a cylinder and a plummet.

**Pressure Accumulation**

Calculation is based upon Boyle-Charles' Law.

$pV/T$  (constant), T: Temperature (K) [absolute temp.]

The relationship between the inner gas pressure and the volume is as follows.

$$P_1V_1 = p_2V_2 = p_3V_3$$

(the product of the pressure and volume is constant.)

From the above and  $\Delta V$ : output flow ( $V_3 - V_2$ ),  $V_1$  is calculated as follows.

$$V_1 = \frac{\Delta V (p_2 p_3)^{1/n}}{p_1^{1/n} (p_3^{1/n} - p_2^{1/n})}$$

- $p_1$  : Pre-charge pressure (MPa(psi))
- $p_2$  : Min. operating pressure (MPa(psi))
- $p_3$  : Max. operating pressure (MPa(psi))
- $n$  : Polytropic exponent
- $V_1$  : Accumulator volume (L(gal))
- $V_2$  : Gas volume at  $p_2$  (L(gal))
- $V_3$  : Gas volume at  $p_3$  (L(gal))
- $\Delta V$ : Output flow (L(gal))

Figure 11.10 shows the accumulated condition of a bladder-type accumulator.  $V_3 - V_2$  is equal to the output volume.

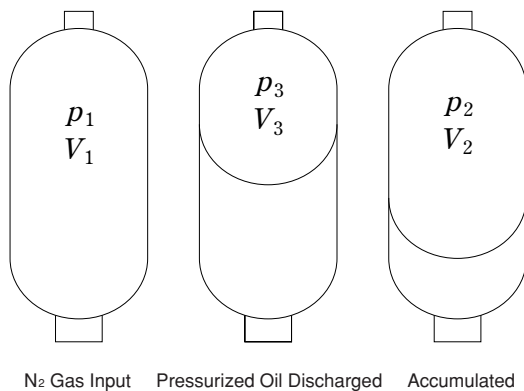

Fig. 11.10

**Cautions on Usage of Accumulators**

- (1) Accumulators should be vertically positioned so that their oil ports face down.
- (2) Pre-charge pressure should be approximately 85 to 90 percent of the minimum working pressure, and should not be less than 25 percent of the maximum working pressure.
- (3) Inert nitrogen gas ( $N_2$ ) should be used, while oxygen is strictly prohibited.

**Changing Conditions of Gas**

Changing conditions of gas under accumulation can be classified into isothermal, adiabatic, and polytropic changes.

(1) Isothermal change

When accumulation and output flow take a long time, heat generated in the action is completely absorbed into the surrounding atmosphere. As a result, there is no noticeable temperature change. Such volumetric change in accumulation, in association with temperature, is called isothermal change. In this case, the polytropic index is one.

(2) Adiabatic change

When accumulated gas is flashed out instantly, the gas expands or contracts with no heat exchange with the surrounding atmosphere. This type of volumetric change is called adiabatic change. Its polytropic index is 1.4.

(3) Polytropic change

No heat transfer takes place in adiabatic change, while all generated heat is transferred in isothermal change. In reality, pressure accumulation and discharge are accompanied with gas movement. The gas temperature, thus, changes after these phases with heat exchange. Temperature change caused by accumulation and discharge is not parallel with external temperature change. The gas temperature increases as the pressure accumulates, resulting in larger energy accumulated than in the case of isothermal change. The gas temperature, on the other hand, decreases as the pressure is released, generating a smaller amount of output flow. Polytropic change is generally obtained by the mean working pressure and the passage of time.

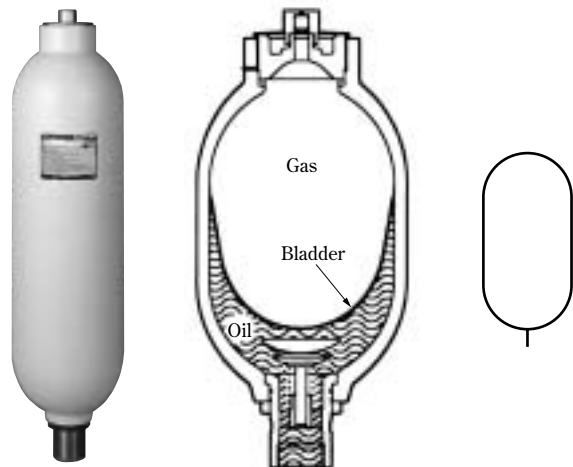

Fig. 11.11

## 11-3 Heat Exchangers

Energy generated by a prime mover transforms into thermal energy, which increases the working fluid temperature in a hydraulic system. Higher temperature deteriorates the working fluid and leads to significantly shorter fluid life. Cooling the working fluid and maintaining its temperature at a certain level are required for smooth system operation. In a cold region, in contrast, where the surrounding temperature drops below freezing, the viscosity of working fluids becomes high. The suction resistance increases, causing more pressure loss in the system. Heating the working fluid is necessary to keep it in a proper condition.

### 11-3-1 Coolers

Water-cooling heat exchangers are the most popular because they provide the highest cooling efficiency. However, in recent years, air-cooling heat exchangers, which do not require cooling water, have become popular for compact units in machine tools. Heat exchangers with circulating coolants are widely employed in machine tools because of their high accuracy.

- (1) Tubular heat exchanger: this exchanger delivers a working fluid through many copper tubes to accomplish heat exchange between the working fluid and the cooling water.

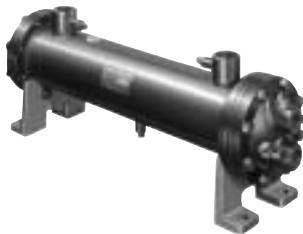
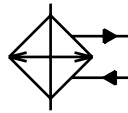

Fig. 11.12



- (2) Plate heat exchanger: this exchanger consists of many thin plates, which dissipate heat with the cooling water.



Fig. 11.13

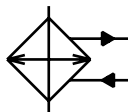

- (3) Air-cooling radiator: this exchanger has many fin tubes to cool the working fluid with air flow through the tubes.

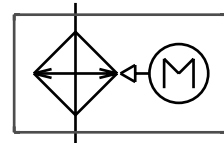

Fig. 11.14

- (4) Refrigerant heat exchanger: this exchanger uses a coolant gas and a compressor, similarly to home air conditioners, to dissipate heat from the working fluid. The unit is comprised of a hydraulic pump for circulation, a motor, and thermo control equipment such as a thermostat. This heat exchanger is used for applications where highly accurate temperature control is required.



Fig. 11.15

### 11-3-2 Heater

An electronic heater is widely used as a general heating tool. For large reservoirs, a steam heater is employed to deliver heat through pipelines to reservoirs.

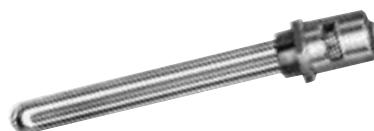

Fig. 11.16

## 11-4 Measuring Instruments

Usage of appropriate measuring instruments varies depending on the objectives of daily, weekly, and monthly inspections. Instruments are classified according to the sections to be checked and their procedures, as shown in the table 11.2.

Table 11.2

	Visual Inspection	Electric Contact	Continuous Signal
1. Pressure Measurement	Pressure Gauge	Pressure Switch	Pressure Sensor
2. Flow Measurement	Flow Meter	Flow Meter with an Electric Contact	Remote Flow Meter
3. Thermo Measurement	Thermometer	Thermo Switch Level Switch	Tele-thermometer
4. Hydraulic Fluid Volume Measurement	Oil Level Gauge	Level Switch	Remote oil level gauge

### 11-4-1 Pressure Measurement

- (1) Bourdon tube pressure gauge: this gauge is the most popular for visual inspections. Its case is usually filled with glycerin to protect the gauge from vibrations in hydraulic systems.



Fig. 11.17

- (2) Pressure gauge with an electric contact: the following types are available.
- i. Hydraulic piston type: this type turns a micro switch on and off by pushing a spring.
  - ii. Bellows type: this type turns a micro switch on and off by pushing a bellows (as in the hydraulic piston).
  - iii. Bourdon tube type: it turns a micro switch on and off in the same way as a pressure gauge.
  - iv. Pressure gauge with semiconductor

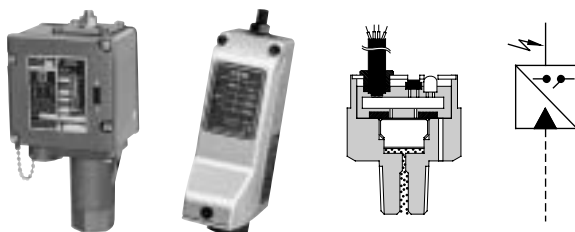

Fig. 11.18

- (3) Pressure sensor: this sensor outputs continuous signals for hydraulic system monitoring or servo system feedback.



Fig. 11.19

### 11-4-2 Flow Measurement

- (1) Flow meter: a sight flow indicator is used to check whether the working fluid is flowing or not by simple visual inspection. Another type is a cone flow meter or a flapper type flow meter in which a gauge is embedded.

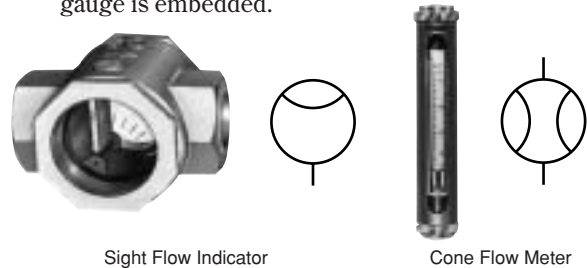

Fig. 11.20

- (2) Flow meter with an electric contact: an electric contact is attached to a cone flow meter or a flapper type flow meter.

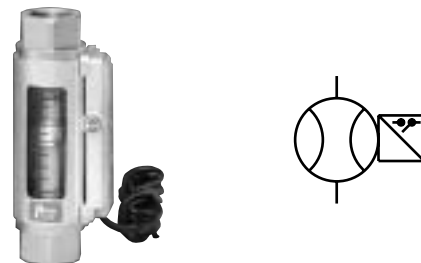

Fig. 11.21

- (3) Flow meter for continuous signal output: the following types are available.
- i. Positive displacement flow meter (gear motor)
  - ii. Turbine flow meter
  - iii. Ultrasonic flow meter
  - iv. Differential pressure flow meter
- Positive displacement flow meters are widely used in hydraulic equipment. Sometimes, they are comprised of a hydraulic motor and a pulse encoder.

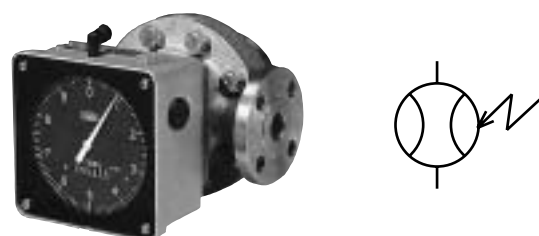

Fig. 11.22

### 11-4-3 Thermo Measurement

- (1) Thermometer: generally, the following types are available for visual inspection.
- i. Bar thermometer with a protective tube
  - ii. Bimetal thermometer
  - iii. Remote-reading panel-mounted thermometer

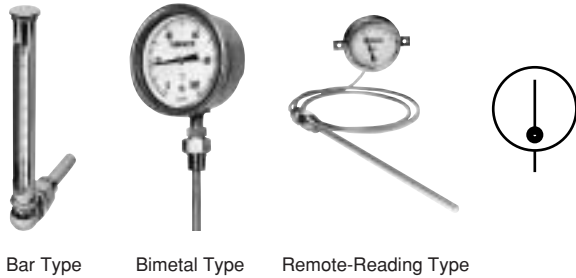

Fig. 11.23

- (2) Thermometer with an electric contact: the following types are available.
- i. Thermostat type
  - ii. Remote-reading thermometer with an electric contact type: the electric contact type and a micro switch type are available.

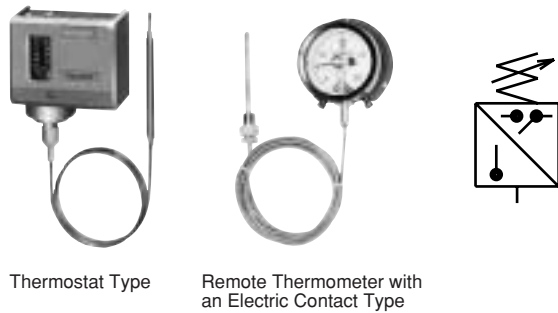

Fig. 11.24

- (3) Thermometer for continuous signal output: generally, this thermometer uses a thermo sensor (temperature detector) to indicate temperatures. The following types of temperature detectors are available. The shape of the detector and setting-up condition should be considered when making the selection.
- i. Platinum resistance thermometer
  - ii. Thermo-couple
  - iii. Thermistor thermometer

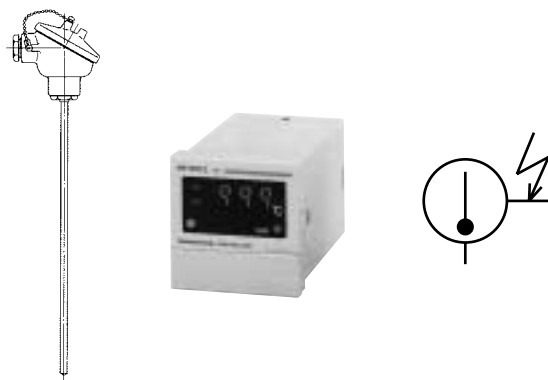

Fig. 11.25

### 11-4-4 Hydraulic Flow Volume Measurement

- (1) Oil level gauge: acrylic-bar oil level gauges are widely selected for a general visual inspection. It is possible to attach a thermometer at a lower part of the gauge. A gauge with a shuttle valve or a remote-reading gauge should be used according to the Fire Service Law, if applied.

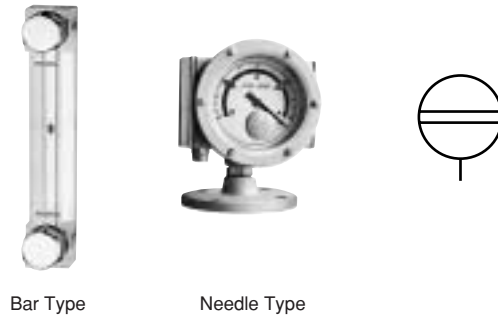

Fig. 11.26

- (2) Oil level gauge with an electric contact: two types are available. One is equipped with an electric contact with a needle for visual inspection, and the other is with an electric contact with a read switch.

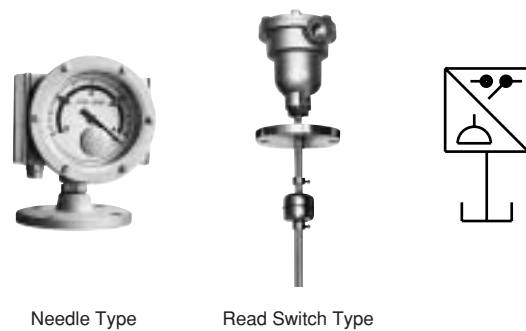

Fig. 11.27

- (3) Oil level gauge for continuous signal output: generally, two types are available. One is equipped with an electric contact providing continuous signals. It indicates the oil level by a needle for visual inspection. The other type is equipped with a sensor only. The sensor is usually of a resistance type or a magnetorestrictive type.

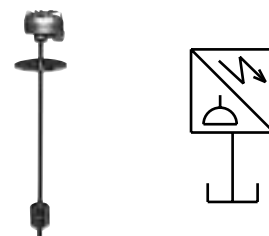

Fig. 11.28

## 11-5 Valves

The following valves are available for system maintenance and fluid temperature control.

### 11-5-1 Low Pressure Stop Valves

These valves are used in maintenance. The following types are among the selections available for line connections: screwed type and flange type.

- i . Ball valve: this valve opens/closes with 90-degree rotation of a knob
- ii . Glove valve: this valve has the same structure as the valve for high pressure use
- iii. Gate valve: this valve is placed in an inlet line.

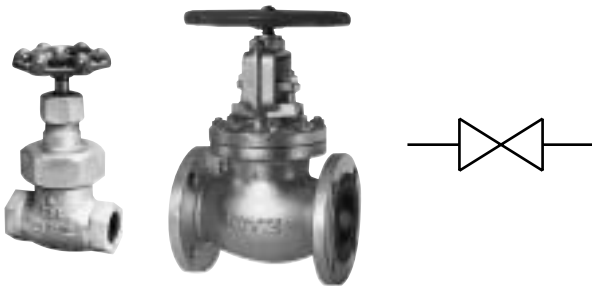

Fig. 11.29

### 11-5-2 High Pressure Stop Valves

The glove and ball types are available. These valves can be connected with a screwed connection, flange, and manifold. Various combination valves are available as required by their use.

- i . Glove valve

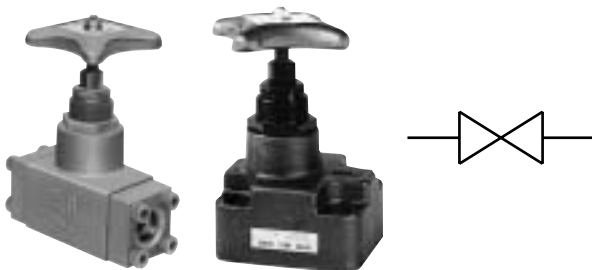

Fig. 11.30

- ii. Ball valve  
This valve provides low flow resistance and small internal leakage. It can be opened/closed with one-touch operation. A three-way valve is also available.



Fig. 11.31

- iii. Combination valves
  - a) Accumulator stop valve: this valve, designed for accumulator maintenance, serves as a stop

valve for the supply and drain lines. It can be connected with a flange or a manifold.

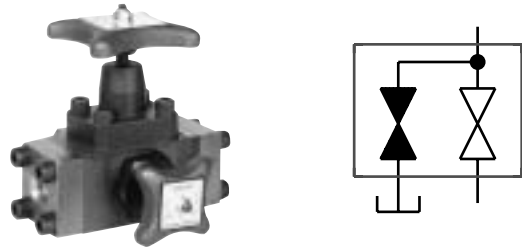

Fig. 11.32

- b) Maintenance valve: this valve is used for maintenance of solenoid and relief valves.



Fig. 11.33

### 11-5-3 Water Solenoid Valve

This valve opens/closes a cooling water supply line. A signal from a thermal switch turns the valve on/off to sustain the working fluid temperature at a constant level.

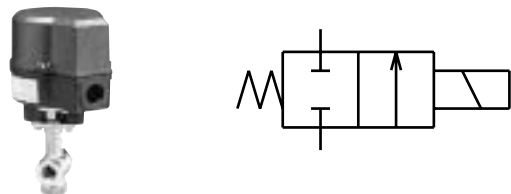

Fig. 11.34

### 11-5-4 Automatic Water Supply Valve with a Temperature Detector

The valve automatically opens to supply cooling water and decrease the temperature when a temperature detector placed in a reservoir detects that the working fluid temperature reaches a certain level. Depending on the detected temperature, the valve can adjust the cooling water supply.

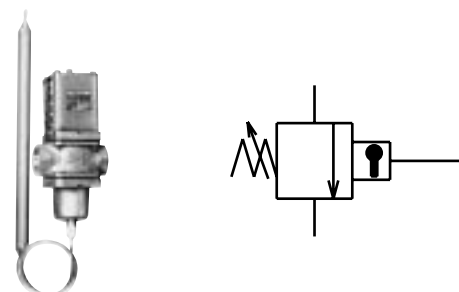

Fig. 11.35



Other accessories for connection are available, including couplings, hoses, self-sealing couplings, rotary joints, and piping joints.

### 11-6-1 Shaft Couplings (Couplings)

These couplings connect a pump shaft and a prime mover. With due consideration to axial misalignment of shafts in hydraulic equipment, the following couplings are available.

- (1) Flange-type flexible-shaft coupling: with two flanges, this coupling uses the properties of rubber bush applied as a coupling bolt. Deformation of the rubber eliminates the axial misalignment.
- (2) Chain coupling: this coupling connects two shafts with double-lined roller chains, and it uses a sprocket roller, which provides space between feeding crows, to prevent misalignment. This coupling is compact and light, but requires grease as a lubricant.

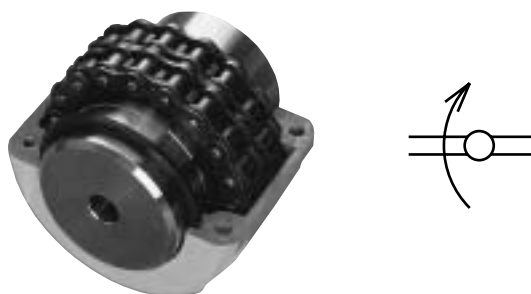

Fig. 11.36

- (3) Rubber/plastic coupling: this coupling is made of rubber or plastic for torque transmission. Its maximum rotation speed and transmittable torque are lower than other couplings. The coupling, however, provides a large misalignment tolerance, high vibration and shock absorption, and low noise.

### 11-6-2 Rubber (plastic) Hoses

Rubber hoses are used when metal-tube connection is not allowed, some moving parts are present, and vibration protection is required. The hose consists of an inner layer, a reinforcement layer, and an outer layer, and couplings are connected to each end. In selecting rubber hose, due consideration should be given to working pressure, working fluid, working temperature, bore, and coupling shape.



Fig. 11.37

### 11-6-3 Self-Sealing Couplings

This coupling allows connection/disconnection of rubber hoses with one-touch operation.



Fig. 11.38

### 11-6-4 Rotary Joints

This joint transmits working fluids to rotary parts. The rotary and swivel types are available.

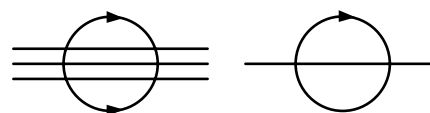

Fig. 11.39

### 11-6-5 Fittings

Screw, flange, welded, flare, and flareless fittings are available for line connection and equipment setup. In addition, the following fittings are among the available selection.

- (1) Socket: Connects lines into straight configurations. Fittings that connect lines with different bores are called reducer.
- (2) Elbow: Changes directions of lines. Elbow fittings for lines with different bores are also available. 90-degree elbows and 45-degree elbows are among the available selections.
- (3) Tee (tees): Branches out or in lines.
- (4) Nipple: Has male threads at both end to connect lines into straight configurations.
- (5) Bush: Has a male and female thread at each end to connect lines into straight configurations. They are usually adapted for lines with different bores.
- (6) Cap: Closes the male thread port.
- (7) Plug: Closes the female thread port.
- (8) Union: Uses screw caps to allow easy disconnection of lines. It is equipped with packing like O-rings.
- (9) Flange: Seals line connection with O-rings and tightens it with bolts. It is most generally used for fitting.

The following flanges are available in the inserted welding and butt welding types.

- i. JIS-compatible high-pressure rectangular flange
- ii. SAE-compatible oblong flange (hexagon)
- iii. JIS-compatible low-pressure sphere flange

# 12

## HYDRAULIC UNITS

The units are packaged hydraulic power sources, including a hydraulic reservoir, a pump, a motor, and other equipment.

12-1 Reservoirs

12-2 Others

### 12-1 Reservoirs

#### 12-1-1 Requirements for Hydraulic Reservoirs

- (1) A reservoir should be set up with a method to shut out foreign substances such as dust. Example: Filter at a ventilation or a filling port.
- (2) A reservoir should be set up so that its components can be easily detached for smooth maintenance.
- (3) A reservoir should have an oil level gauge for safety.
- (4) A baffle plate should be placed between the return and suction pipes to prevent foreign substances from being drawn back through the hydraulic system.
- (5) Return and suction lines should be installed below the oil level.
- (6) A side cover should be included in a reservoir to facilitate the inner coating and cleaning processes.
- (7) Safety Laws (for ex. Fire Service Law in Japan), where applicable, regulates the following items: empty space in the reservoir, level gauge type, and the oil pan volume, etc. Applicable ordinances and regulations depend on the operating pressure and the flash point of the working fluid. Local laws and regulations may also be applicable. For local regulations, their applicability should be checked in advance with the local fire departments and system users.

#### 12-1-2 Selection of Reservoir Capacity

- (1) Selection Based on Pump Output Capacity  
Generally, reservoir capacity should be three to five times larger than the pump output capacity. In a

closed circuit, the reservoir capacity can be about 50 percent of the pump output capacity.

- (2) Selection Based on Oil Level Variation

The amount of oil in a reservoir fluctuates with actuator operation. The reservoir should have return and suction lines where the oil can be kept, regardless of oil level fluctuations. Capacity that is three times larger or more than the minimum oil level is generally recommended.

- (3) Selection Based on Heat Radiation Area

Heat generated by hydraulic equipment is radiated from the reservoir surface. The recommended reservoir size is, therefore, determined by the presence of a heat exchanger.

- (4) Selection Based on Space of Reservoir Top

For mounting of a pump, a motor, and valves on the reservoir top, the space of the reservoir top should be taken into consideration.

- (5) Compliance with the Safety Laws

The law stipulates that empty space in a reservoir must be equal to or less than ten percent of the reservoir capacity in Japan.

Figure 12.1 shows an example of a hydraulic unit containing a pump, a motor, and control valves. The figure also shows names of optional components and settings.

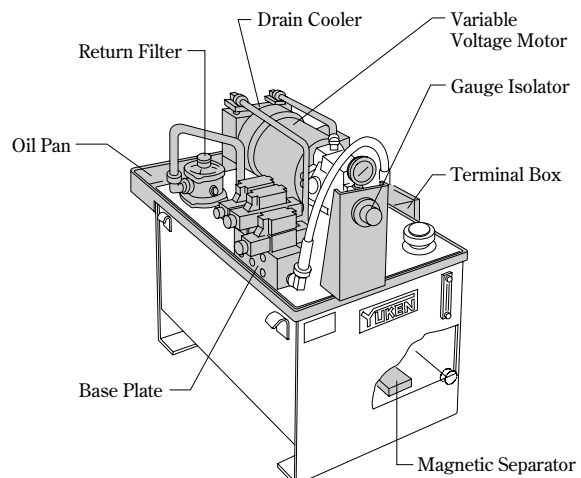

Fig. 12.1 Hydraulic Unit (Hydraulic Power Source)



## 12-2 Others

### 12-2-1 Manifold

Manifolds connect ports of hydraulic components with drilled metal blocks, instead of piping. They usually have outlet ports with tapered threads (Rc) or connection flanges. Manifolds have the following advantages.

- i. They can reduce leakage and vibrations with simple piping.
- ii. They are compact.
- iii. Their assembly does not require trained skills; installation is easy and quickly completed.
- iv. Base blocks of 1/8- and 3/8-inch bores have been standardized for modular valves.

Manifolds are made of the following materials.

- i. SS material: Often selected for customized units.
- ii. SUS material: Used when rust should be prevented.
- iii. SF (forging) material: Employed for high pressure applications.
- iv. Continuous casting material: Chosen with consideration to cost performance.
- v. Aluminum material: Used for light weight applications, such as vehicles.

### 12-2-2 Cautions on Piping and Assembling

A hydraulic unit may incorporate steel pipes, stainless pipes, or hoses.

**Table 12.1 Steel Pipe Types**

Spec.	Names	Symbols
JIS G 3452	Carbon-steel pipes for ordinary piping (gas pipe)	SGP
JIS G 3454	Carbon-steel pipes for pressure service	STPG
JIS G 3455	Carbon-steel pipes for high pressure service	STS
JIS G 3445	Carbon-steel pipes for machine structure purposes	STKM
JIS G 3459	Stainless-steel pipes	SUS304
JIS B 2351 (Appendix)	Precision carbon-steel pipes for compression fittings	STPS1 STPS2
JOHS 1006	Precision carbon-steel pipes for hydraulic piping	OST1,2

Nominal size of pipes: A (millimeter) and B (inch), outer diameter is same. Scale A (millimeter) is usually applied to pipes for flareless fittings.

Schedule: it refers to wall thickness and is denoted as Sch. See Tables 12.2 and 12.3 for pipe selections in accordance with the working pressure.

### • Cautions on Piping and Assembling

- i. Use Teflon tape for thread sealing.
- ii. Remove burrs and chips after cutting the pipe and threading. Avoid using dull cutting tools and dies.
- iii. Make sure that the curvature radius of a pipe is 2.5 to 3 times larger than its inner bore.
- iv. Use pipe cramps to eliminate shocks and vibrations, if necessary.
- v. Attention should be paid to the following points when a flexible hose is applied.
  - a) The curvature radius is greater than the specified minimum radius
  - b) A hose is not twisted.
  - c) Extra hose length is required because the hose expands with increased inner pressure.

**Table 12.2 Steel Pipes (SGP, STPG, STS, and STKM)**

Nominal Sizes		Outer Diameter mm	Wall thickness against Working Pressure					
(A)	(B)		1.5 MPa	7 MPa	21 MPa	35 MPa		
8	1/4	13.8	Sch40 (SGP)	Sch80	Sch80	Sch80		
10	3/8	17.3						
15	1/2	21.7						
20	3/4	27.2						
25	1	34.0						
32	1-1/4	42.7						
40	1-1/2	48.6			Sch160	Sch160	SchXXS (STKM)	
50	2	60.5						
65	2-1/2	76.3						
80	3	89.1						
90	3-1/2	101.6						
100	4	114.3						
125	5	139.8						
150	6	165.2						Sch160

**Table 12.3 Tubes for Flareless Fittings**

Outer diameter (mm)	Wall thickness against Working Pressure (mm)		
	14 MPa	21 MPa	35 MPa
6	1.5mm	1.5mm	1.5mm
8			
10	2.0mm	2.0mm	2.0mm
12			
15	2.5mm	2.5mm	2.5mm
18			
20	3.0mm	3.5mm	3.5mm
22			—

# B

## TROUBLESHOOTING FOR HYDRAULIC EQUIPMENT

Problems with hydraulic equipment can be grouped into eight categories, such as pump discharge failure and excess heat generation. The table below sums up the trouble causes and repairs and checks.

Problem	Cause	Repair/Check
1. The pump does not discharge the working fluid.	1. The rotation direction is incorrect.	Make sure that the direction is correct.
	2. The pump shaft is not rotating.	Check and modify the shaft key and coupling.
	3. The suction filter is clogged.	Remove the clogging.
	4. Air is in the suction line.	Fix the pipe connection (screwed part and packing).
	5. The working fluid is too viscous to flow into the pump.	Replace the fluid or heat it with a heater.
	6. The pump is placed too high.	Decrease the suction height (head).
	7. The pump rotation speed is too low.	Drive the pump at the specified rotation speed.
	8. The amount of the fluid in the reservoir is insufficient.	Add the fluid to the recommended level.
	9. Air is not bled at the pressurized side; suction cannot take place.	Take the air out of the highly pressurized line by loosening the line.
	10. The variable displacement pump is improperly adjusted.	Check and correct the adjustment.
	11. Parts are worn or damaged.	Repair or replace the parts.
2. The pump produces noise (cavitation).	1. The suction line or the suction filter is clogged.	Remove the clogging.
	2. The suction line is too narrow or long.	Replace the piping so that the vacuum level is kept below the specified value.
	3. The capacity of the suction filter is insufficient.	Replace the filter with a new one whose capacity is twice or more as large as the pump discharge flow.
	4. The pump is placed too high.	Decrease the suction height (head).
	5. The capacity of the boost pump is insufficient.	Repair or replace the boost pump.
	6. The working fluid is too viscous to flow into the pump.	Replace the fluid or heat it with a heater.
	7. The pump rotation speed is beyond the specified level.	Drive the pump at the specified rotation speed.
	8. The air breather in the reservoir is clogged.	Clean the breather.
3. Pump produces noise (aeration).	1. Suction pipe connection is loose.	Fix the connection (screwed part and packing).
	2. There are foams in the reservoir.	1. The oil level is low: add the working fluid to the recommended level. 2. The reservoir is equipped with no baffle plate, or the reservoir is too small: install an defoaming filter or replace the reservoir
	3. Air is leaking in through the shaft seal.	Replace the shaft seal.
	4. Air is not completely bled from the casing.	Run the system with no load until air is removed completely.
	5. There are bubbles in a line.	Set up an air bleeding circuit for a closed line.
	6. The pressure is beyond the specified level.	Drive the pump at or below the specified pressure.
	7. A coupling produces noise.	Align the shaft or replace the coupling.
	8. Pump parts are worn or damaged.	Repair or replace the parts.

Problem	Cause	Repair/Check
4. Excess heat is generated.	1. Internal leakage in the pump increases.	Repair or replace the pump because its volumetric efficiency is deteriorated.
	2. Internal leakage in the valve increases.	Repair or replace the valve.
	3. Internal leakage in the actuator increases.	Repair or replace the actuator.
	4. The sliding part of the pump is seized up (scoring).	Repair or replace the pump.
	5. The pump or bearing is seized up.	Replace the bearing.
	6. The working fluid in the reservoir is insufficient.	Add the fluid or place a larger reservoir.
	7. Oil cooler selection is improper.	Replace the oil cooler with a new one with a larger heat-exchange capacity.
	8. The oil cooler performance is inadequate.	1. Check the water temperature and volume and take an appropriate action. 2. Overhaul the cooler and remove water strains and other contaminants. 3. Clean the radiator of the fan cooler.
	9. The cooling water in the oil cooler is insufficient. a. The water solenoid valve is not in working order. b. The automatic water supply valve with a temperature detector is not in working order. c. The thermostat is not in working order.	Check whether the temperature difference between the cooling water inlet and outlet is proper. Check and repair the valves and electric systems to make sure that cooling water flow is increased.
	10. The heater is not in working order.	Check and repair the heater and thermostat.
	11. The unload circuit is not in working order. a. The unload set pressure is too high. b. Pressure setting is improper, resulting in a shortened unloading time. c. The accumulator is not in working order, or its capacity is insufficient. d. Gas pressure of the accumulator is low. e. The pressure switch is not in working order.	1. Check and repair the valves. 2. Correct the pressure setting. 3. Replace the failed components. 4. Check and repair the electric systems.
	12. The viscosity of the working fluid is low, resulting in increased leakage.	Replace the working fluid.
	13. The set pressure level is too high.	Correct the pressure setting to an appropriate level.
5. The solenoid directional valve is not in working order (burnout of the coil).	1. Spool operation is failed because of dust.	Clean the spool and replace the coil.
	2. The voltage is too high or low.	Set the voltage at a proper level and replace the coil.
	3. Insulation failure is caused by water.	Eliminate the failure cause and replace the coil.
	4. Direction control is failed due to an excess flow.	Adjust the flow rate at a proper level or place a larger valve.
	5. Direction control is failed due to a hydraulic lock.	Install a filter or replace the existing filter to a seat type.
6. The pressure control valve is not in working order.	1. The pressure falls below the setting level. a. The valve is not properly seated. b. The orifice is clogged with dust. c. Stick-slip is taking place because of dust. d. The valve spring is damaged.	• Overhaul the valve. • Replace the valve and seat. • Replace the worn or damaged parts.
	2. The pressure oscillates (caused by other than the factors above). a. The working fluid contains air. b. The capacity of the bent line is too large. c. The valve resonates with other valves.  d. Flow is excessive.	a. Remove the air from the fluid. b. Make the bent line thin or short or squeeze it. c. Replace the valve spring to change the characteristic frequency. d. Adjust the flow to a proper level or place a larger valve.
	1. Knocking is caused by air in the working fluid.	Remove the air from the fluid.
	2. Knocking is caused by packing resistance.	Apply molybdenum disulfide coating to the piston or replace the packing.
7. The actuator (cylinder) is not in working order.	3. Knocking is caused by the bump at the load side.	Perform the centering of the actuator and make the load line smooth.
	4. Knocking is caused by a poor condition of the inner surface of the tube.	Repair the tube.
	5. Knocking is caused by improper operation of the control valve.	Inspect and eliminate the failure cause.
	6. Air in the working fluid causes thrust reduction.	Remove the air from the fluid.
	7. Insufficient pressure causes thrust reduction.	Inspect and eliminate the failure cause.
	8. Internal leakage causes thrust reduction.	Repair the failure (replace the packing).
8. Maintenance and management of the hydraulic system	Perform the following actions for maintenance and management of the hydraulic system. 1. Keep the working fluid clean (see Chapter 14 HYDRAULIC FLUIDS). 2. Make sure that operating conditions are correct, and keep the system in an order that allows appropriate action to be quickly taken if required. The following values should be known for system maintenance and management. (1) Saturation temperature in a reservoir (comparison with the room temperature). (2) Input power supplied when a fixed displacement pump is unloaded or when a variable displacement pump is fully cut off (ampere). (3) Input power at maximum load (ampere). (4) Drain rate for a variable displacement pump (L/min (U.S.GPM)). (5) Pump noise level [noise level at unloading and maximum loading (dB(A)) and noise quality] These values increase with lower pump efficiency and more internal leakage in valves.	

# 14

# HYDRAULIC FLUIDS

- 14-1 Selection
- 14-2 Petroleum-Based Fluid
- 14-3 Viscosity
- 14-4 Contamination Control
- 14-5 Application Limit
- 14-6 Contamination Measurement Instruments
- 14-7 Fire Resistant Fluid
- 14-8 Biodegradable Fluid

## 14-1 Selection

Hydraulic equipment is comprised of many kinds of hydraulic appliances, and does its job by transmitting energy through a non-compressible medium. In general, petroleum-based fluid is used as a medium, and is called working fluid. Hydraulic equipment works under conditions of high pressure and high speed. Also, many kinds of materials are used for the equipment, and temperature of the fluid under operation and other conditions may change the performance of the working fluid. When these conditions are considered, the following characteristics are demanded of the working fluid.

- (1) Viscosity is stable despite temperature fluctuations.
- (2) Stable flow-ability must be reached under low temperature.
- (3) Change in quality and performance is minimal under high temperature.
- (4) Desirable oxidation stability is met.
- (5) Shear-ability needs to be invariable.
- (6) It does not corrode metals.
- (7) It needs to prevent rust.
- (8) Rubber and coating inside pipes must not be eroded.
- (9) Fluid is non-compressible.
- (10) Ability to elimination foam is high.
- (11) It must have the maximum possible resistance to fire.

JIS specifications for hydraulic working fluid do not currently exist. But, specialized hydraulic working fluid with viscosity equivalent to turbine oil with additives in petroleum lubricant is most widely accepted.

Synthetic working fluid and water-based working fluid are selected when danger of fire is present because of leakage or blowout of the fluid. These working fluids have different characteristics from petroleum-based fluid; caution is needed for practical use. Also, because of the increasing emphasis on socially-sustainable materials, biodegradable, vegetable oil based working fluids can be employed. Figure 14.1 shows the classification of working fluid used in hydraulic equipment. Table 14.1 presents characteristics of each working fluid.

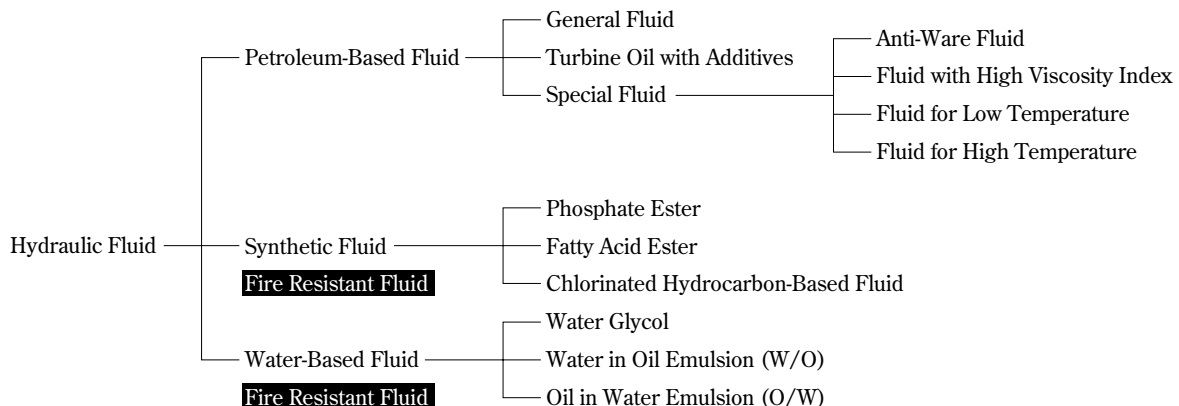

Fig. 14.1

**Table 14.1 Characteristics of Each Working Fluid**

Item \ Type	Petroleum-Based	Phosphate Ester	Fatty Acid Ester	Water Glycol	Water in Oil Emulsion	Oil in Water Emulsion	
Specific Gravity (15/4°C)	0.87	1.13	0.93	1.04~1.07	0.93	1.00	
Viscosity (cSt (SSU))	40°C	32.0 (150)	41.8 (191)	40.3 (188)	38.0 (177)	75.1 (348)	0.7
	100°C	5.4 (44)	5.2 (43)	8.1 (52)	7.7 (53)	—	—
Viscosity Index (VI)	100	20	160	146	140	—	
Max. Working Temp. (°C)	70 (158 °F)	100 (212 °F)	100 (212 °F)	50 (122 °F)	50 (122 °F)	50 (122 °F)	
Min. Working Temp. (°C)	-10 (14 °F)	-20 (-4 °F)	-5 (23 °F)	-30 (-22 °F)	0 (32 °F)	0 (32 °F)	
Compressibility (1/MPa (1/psi))	About 6×10 <sup>-4</sup> (4.14×10 <sup>-6</sup> )	About 3×10 <sup>-4</sup> (2.07×10 <sup>-6</sup> )	—	About 3×10 <sup>-4</sup> (2.07×10 <sup>-6</sup> )	About 4×10 <sup>-4</sup> (2.76×10 <sup>-6</sup> )	About 5×10 <sup>-4</sup> (3.45×10 <sup>-6</sup> )	
Life Expectancy of Pump (%) Vane Pump 2 000 psi	100	90	80	80	40	20	
Strainer Resistance	1.0	1.03	1.0	1.2	0.7~0.8	Same as water	
Influence on Metal	None	Al for sliding parts Not allowed	None	Al, Cd, Zn Not allowed	Cu, Cd, Zn Not allowed	None	
Influence on Rubber materials	Silicon, Butyl, Ethylene propylene Not allowed	Nitrile, Urethane, Chloroplylene Not allowed	Butyl Not allowed	Silicon, Urethane, Synthetic Rubber Not allowed	Silicon, Butyl, Ethylene propylene, Urethane, Synthetic Rubber Not allowed	Silicon, Butyl, Ethylene propylene, Urethane, Synthetic Rubber Not allowed	
Influence on Coating	Epoxy, Phenolic Inner Coating Allowed	Inner Coating Strictly Prohibited (Chemical Conversion Coating Allowed)	Phenolic Inner Coating Not Allowed	Inner Coating Strictly Prohibited (Chemical Conversion Coating)	Inner Coating Strictly Prohibited (Chemical Conversion Coating)	Epoxy Inner Coating Allowed	
Relative Price	1	7	5	4	1.5	0.1~0.15	

**14-2 Petroleum-Based Fluid**

Working fluid with the equivalent viscosity of turbine oil in petroleum lubricant is selected. There are two types of turbine oil: turbine oil without additives (first type) and with additives (second type). The second type contains anti-rust additives and antioxidants, etc. Working fluids manufactured under the following are widely used. 1) JIS K 2213 second type: turbine oil with additives---ISO VG32, VG46, VG68, 2) specialized working fluid “R&O” type with a viscosity equivalent to turbine oil with additives, and 3) “AW (anti-wear)” type.

Selection of working fluid is based upon the general characteristics of fluid (specific gravity, color, flash point, viscosity, total acid number, etc.) and upon data from special tests (lubricity, oxidation stability, stability of shear-ability, etc.); both of the characteristics and the data are presented by manufacturers to users and manufactures of hydraulic equipment. Users need to select proper working fluid, taking into consideration the suitability of the fluid for the equipment and its durability. General characteristics are guidelines for users and assure the quality and standard value of each working fluid. These characteristics and data are also used to compare old and new working fluids; the continuous use shall be determined by comparing the degree of fluid deterioration. Table 14.2 gives examples of general characteristics of petroleum-based fluid.

**Table 14.2 General Characteristics of Petroleum-Based Fluid**

Characteristics \ Type	Appearance	Flash Point COC °C (°F)	Kinematic Viscosity mm <sup>2</sup> /s (SSU)	Viscosity Index	Pour Point °C (°F)	Total Acid Number mgKOH/g	Spec. VG46
			40°C (104 °F)				
Turbine Oil with Additives	—	200 (392) or above	41.4~50.6 (190~234)	95 or above	-7.5 (18.5) or below	0.3 or below	JIS K 2213
Hydraulic Working Fluid	Clear and colorless	185 (365) or above	41.4~50.6 (190~234)	90 or above	-15 (5.0) or below	—	ASTM D6158
Anti-Wear Working Fluid	Clear and colorless	185 (365) or above	41.4~50.6 (190~234)	90 or above	-12 (10.4) or below	—	ASTM D6158

Users should consult federal, state and local laws for regulations concerning the handling of petroleum based fluid. In Japan, handling of petroleum-based fluid and hydraulic equipment with specified reservoir sizes is regulated by “hazardous substance class 4” in the Fire Service Law. For instance, class 4 petroleum in hazardous substance class 4 is regulated when the total volume of the oil is 6 000 liters (1 585 gal) or more.

## 14-3 Viscosity

Kinematic viscosity (absolute viscosity divided by density) [ $m^2/s$ ] is used to determine the value of viscosity of industrial lubricants, such as working fluid. Practically, mm square per second [ $mm^2/s$ ] is used, and its value is the same as the value of customary employed centistokes [cSt]. The process of viscosity calculation is specified in "Determination of Kinematic Viscosity and Calculation of Viscosity Index from Kinematic Viscosity" in JIS K 2283, which recommends the use of a thin tube and scale of [ $mm^2/s$ ] for the calculation. Saybolt Seconds Universal [SSU] measured by Saybolt viscosity gauge is also practically used.

The viscosity of working fluid is very important for hydraulic equipment. Working fluid with inappropriate viscosity causes poor pump suction, lubrication, and valve operations, and enhances internal leakage and heat in circuits, which eventually lead to shortened lives and can eventually lead to shorter machine life and an increased possibility of equipment failure or accidents. On the other hand, working fluid with low viscosity is suitable for saving energy by reducing piping resistance. Also, high viscosity index fluid helps to shorten warm-up time in winter. JIS K 2001 "Industrial Liquid Lubricants-ISO Viscosity Classification," classifies the viscosity spectrum of ISO VG 2 to 3 000 into 20 grades. Figure 14.2 shows the spectrum. It is only relevant to hydraulics. Figure 14.3 clarifies viscosity-and-temperature performance of working fluid with viscosity grades of VG22- VG150.

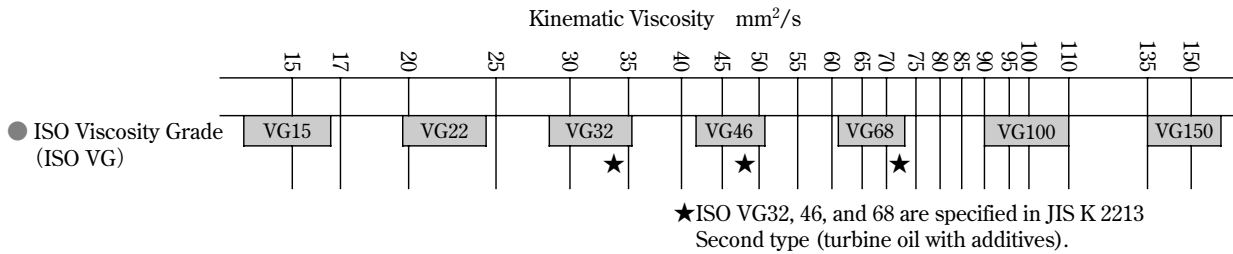

Fig. 14.2 Viscosity Spectrum of Working Fluid

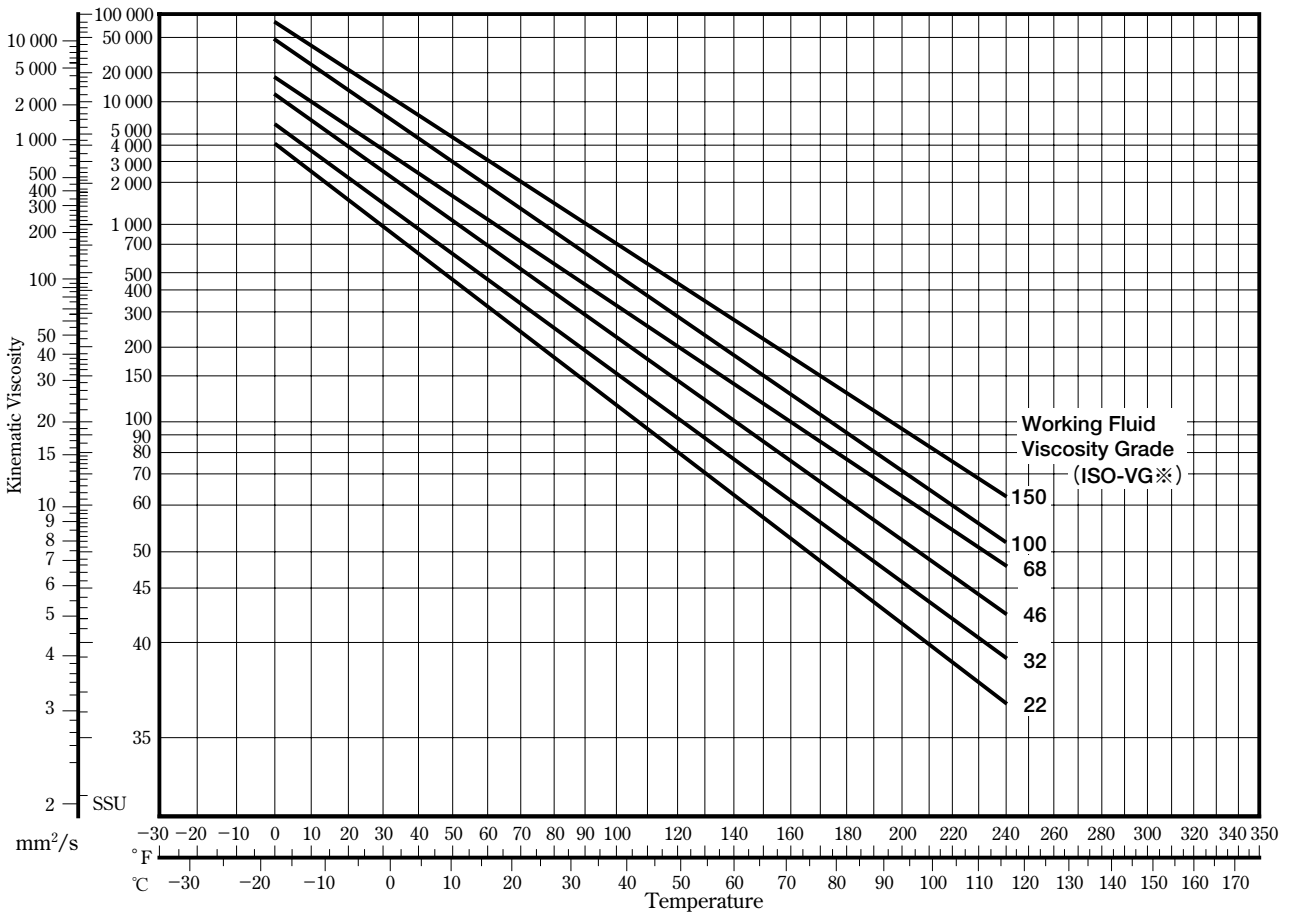

Fig. 14.3 Viscosity of Working Fluid vs. Temperature Characteristics



## 14-4 Contamination Control

There are three reasons for working fluid to be replaced.

- (1) Change in quality and deterioration of working fluid
- (2) Dust or external elements mingled in working fluid
- (3) Moisture mingled in working fluid during its operation

Table 14.3 is a reference for deterioration and quality change. Contamination by dust and moisture is common, and causes abrasion in pumps and valve malfunction. The size of particles in working fluid, ranging from a few to ten, twenty, and thirty  $\mu\text{m}$ , can have a negative impact on the performance of machines equipped with actuators and precision valves such as servo valves. Because of this, the following measurements are necessary to keep the contamination within a standard range: 1) Measurement of dust and particles in working fluid based on "Determination of particulate contamination by the counting method using a microscope", specified in JIS B 9930, 2) Calculation of the number of particles by an automatic particle counter, 3) Observation of particles by the simple measuring instrument shown in Fig. 14.4, and 4) Measurement of particle mass.

Measurement of cleanliness is conducted with equipment that filters 100 mL of working fluid. Particles are gathered on a millipore<sup>1)</sup> filter, and their numbers and sizes are measured, and classified according to Table 14.4. Contaminated working fluid is classified based on dust mass according to Table 14.5. Cleanliness of general working fluid, as a new oil, is classified into approximately class 6 to 8 shown in Table 14.4.

Note 1) Millipore filter: filter with microscopic holes, the size of 1/1 000 mm

**Table 14.3 Limitation on General Characteristics Change**

Working Fluid Test Points	Petroleum-Based		Water-Glycol
	General Fluid	Anti-Wear Fluid	
Kinematic Viscosity (40°C (104 °F))* mm <sup>2</sup> /s (SSU)	±10%		±10%
Total Acid Number* mgKOH/g	0.25	a <sup>☆</sup> 0.25	—
		b <sup>☆</sup> ±40%	
Moisture vol %	0.1		37~43

★ : Amount of change.

☆ : Types of additives (a: non-zinc and b: zinc).

This table gives reference for replacement or renewal of the working fluids. There are test points other than these; it is recommended to refer to working fluid manufacturers. For example, the reference value of the total acid number (or acid number), which indicates deterioration of the fluids, varies according to types or amounts of additives. For the water-glycol working fluid, the pH value is controlled as well.

**Table 14.4 NAS Cleanliness Requirements of Parts used in Hydraulic Systems Based on the Counting Technique**

Number of particles in 100 mL

Sizes $\mu\text{m}$	Class (NAS 1638)													
	00	0	1	2	3	4	5	6	7	8	9	10	11	12
5~15	125	250	500	1 000	2 000	4 000	8 000	16 000	32 000	64 000	128 000	256 000	512 000	1 024 000
15~25	22	44	89	178	356	712	1 425	2 850	5 700	11 400	22 800	45 600	91 000	182 400
25~50	4	8	16	32	63	126	253	506	1 012	2 025	4 050	8 100	16 200	32 400
50~100	1	2	3	6	11	22	45	90	180	360	720	1 440	2 880	5 760
100 or more	0	0	1	1	2	4	8	16	32	64	128	256	512	1 024

NAS : National Aerospace Standard

ISO : International Organization for Standardization

**Table 14.5 Classification of Mass Method**

NAS	Class	100	101	102	103	104	105	106	107	108
	mg/100 mL	0.02	0.05	0.10	0.3	0.5	0.7	1.0	2.0	4.0
MIL	Class	A	B	C	D	E	F	G	H	I
	mg/100 mL	1.0 or lower	1.0~2.0	2.0~3.0	3.0~4.0	4.0~5.0	5.0~7.0	7.0~10.0	10.0~15.0	15.0~25.0

MIL : Military Specifications and Standards



## 14-5 Application Limit

General working fluid, as new oil, contains moisture in the amount of 50-80 ppm (0.005-0.008 percent). But, the ratio increases with moisturized air injected by actuators and air breathers. Moisture generates rust on the inner walls of hydraulic equipment, and enhances the deterioration of lubricants and working fluids. Measurement of moisture in working fluid is conducted by the Carl Fisher Method, which uses characteristics of a reagent that reacts only with a set amount of water, with 10 ppm detection range.

The acceptable amount of dust and moisture in working fluid depends on the equipment. Refer to Tables 14.6 and 14.7. The code of JIS B 9933 (ISO 4406) in Table 14.6 indicates a contamination level by pre-set class numbers that correspond to sizes and numbers of particles (for example, the number of particles of 5  $\mu\text{m}$  or greater and the number of particles of 15  $\mu\text{m}$  or greater). Recently, this rating system is beginning to be widely accepted.

**Table 14.6 Limit on Contamination of Entangled Particles**

Condition of Application	Preferable Contamination Control Level in Working Fluid		
	Counting Technique (NAS Class)	JIS B 9933 (ISO 4406)	Mass Method (Reference)
Equipment with Servo Valves	7	16/14/11	—
Equipment with Piston Pump/Motors	9	18/16/13	N A S 107
Equipment with Proportional Electro-Hydraulic Control Valves	9	18/16/13	N A S 107
Equipment with Pressure of 21 MPa (3 046 psi) or above	9	18/16/13	N A S 107
Equipment with Pressure of 14- 21 MPa (2 031~3 046 psi)	10	19/17/14	N A S 108
Hydraulic Equipment for General Low Pressure	11	20/18/15	M I L E

**Table 14.7 Limit on Entangled Moisture in General Fluid**

1 ppm = 1/1 000 000

Condition of Equipments	Application Limit
Equipment in which working fluid turns white or cloudy because of moisture	Replace immediately.
Equipment in which working fluid circulates back to a reservoir, and which runs for a long time without breaks	500 ppm
Equipment with long pipe lines, in which working fluid is not circulated completely	300 ppm
Equipment which does not run for long time (safety equipment), or whose working fluid has almost never been circulated, or similar precision control equipment	200 ppm

## 14-6 Contamination Measurement Instruments

A Contami-Kit is portable and simple. It filters a sample of working fluid, and gathers particles on a membrane filter. The distribution and number of particles are observed with a microscope, and the level of contamination is determined by compared to the standard contamination plates. This kit has the same system of the JIS B 9930 specifications described in section 14-4.

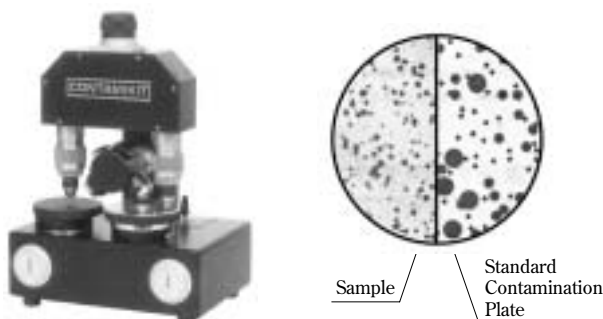

**Fig. 14.4 Contami-Kit**

### ● Specifications

Power Source	AC, DC (For both) AC 100V, DC 6V
Microscope Magnifications	100 times (40 times)
Applied Fluid	Petroleum-Based, Fatty Acid Ester (Water/Glycol)

## 14-7 Fire Resistant Fluid

Whenever fire is present around hydraulic equipment, it cannot be over stated that operators and personnel working in the vicinity are always in danger from potential fire disasters. Working fluid compressed within the equipment can possibly burst out through fractures, cracks, and pinholes. It is almost impossible to stop leakage from the equipment, if it includes exudation and dribbling. The danger of fire disaster can thus never be neglected.

Detailed records of fire accidents have not been kept since hydraulic equipment has become widely utilized. But, actual accidents have occurred quite frequently. The large number of specifications made to assess the flammability of fluids testifies to this fact.

Working fluids chosen for their fire resistance capability are grouped and shown in Fig. 14.8. Many specifications have been created to assess flammability from multiple points of view. One specification compares the flammability of petroleum and hydraulic working fluid, and another compares the relative flammability of two different fire-resistant working fluids. Proper selection should be made based upon applications and conditions, etc.

Possible reasons for fire disaster are presented below. The specifications of combustion tests give due consideration to these causes.

- (1) Working fluid is misted out, and ignited.
- (2) Working fluid is directly poured into a source of fire.
- (3) Working fluid exuded from equipment, or left on rugs or materials, is ignited.

Flammability test methods are categorized into the following two major groups.

- (1) The test gradually increases temperature to the point of ignition, or increases the chance of ignition in a test object. From this, a quantitative scale can be extrapolated. Flash point tests, spontaneous combustion tests, and pipe cleaner tests are representative of this type of test.
- (2) The test is a qualitative method that requires that the conditions necessary for ignition take place. Fluid is left in those conditions and observed to see whether ignition takes place or not. High pressure gas exhaust tests and manifold ignition tests are representative of this type of test.

**Table 14.8 Flammability of Each Working Fluid**

Test	Test Fluid	Oil in Water Emulsion	Water in Oil Emulsion	Water Glycol	Phosphate Ester	Fatty Acid Ester	Anti-Wear Fluid
1. Flash Point Test JIS K 2265	—	—	—	—	266°C~270°C (511~518 °F) 352°C~370°C (666~698 °F)	252°C~266°C (486~511 °F) 316°C~328°C (601~622 °F)	226°C~238°C (439~460 °F) 250°C~254°C (482~489 °F)
2. Spontaneous Combustion Test ASTM E 659	>620°C	424°C	372°C	372°C	564°C	388°C	347°C
3. Manifold Ignition Test Fed-Std. No.791C.6053	Not ignited.	Not ignited.	Not ignited.	Not ignited.	Not ignited.	Combusts on lines.	Combusts on lines.
4. Pipe Cleaner Test Fed-Std. No.791C.352	68-72 times 50-58 times	26-28 times 29-32 times	23-25 times 10-12 times	13-23 times 17-23 times	10-12 times 11-13 times	6-7 times 7-8 times	
5. Flaming Speed Test Luxembourg7th Report	Passed.	Passed.	Passed.	Passed.	Passed. The flam remains for 6 seconds.	Not extinct.	Not extinct.
6. Low Pressure Spray Flash Point Test SAE/AMS3150C	: 40°C : 65°C	None None	0.5 seconds Continuously combusts.	None 0-0.5 seconds	0-0.5 seconds 5.0 seconds	0-0.5 seconds Continuous combusts.	Continuously combusts. Continuously combusts.

Source: Oil-Hydraulics Handbook (revised in 2001) by Japan Fluid Power Association.

## 14-8 Biodegradable Fluid

Biodegradable working fluid is decomposed by microbes to CO<sub>2</sub> and H<sub>2</sub>O, and, therefore, does not have a negative impact on the environment. Base oil is primarily polyethylene glycol or vegetable oil (rape seed oil). The demand for biodegradable working fluid is particularly high for equipment used outdoors, such as excavators and tunnel linings.

Table 14.9 sums up the drawbacks of and treatments for biodegradable working fluid in piston pumps. Attention needs to be paid to mineral oil left inside the system; mineral oil and biodegradable oil should not be mingled. In systems in which attachments are used, residual oil left in attachments requires especial caution.

**Table 14.9 Drawbacks and Actions for Biodegradable Oil in Piston Pumps**

Biodegradable Fluid	Drawbacks	Actions
Vegetable Oil	<ul style="list-style-type: none"> <li>· Weak oxidation stability (short lifetime)</li> <li>· Tendency to have copper alloy corrosion</li> <li>· Expansion and contraction of sealing material</li> <li>· Age deterioration because of mixed water</li> </ul>	<ul style="list-style-type: none"> <li>· Maximum fluid temperature in a reservoir needs to be kept at 80 °C (176 °F) or below.</li> <li>· Working fluid exchange time needs to be shortened.</li> <li>· An assessment test needs to be conducted.</li> <li>· An angled reservoir is required, and water needs to be discharged from the bottom of the reservoir.</li> </ul>
Synthetic Ester	<ul style="list-style-type: none"> <li>· Expansion and contraction of sealing materials</li> <li>· Age deterioration because of mixed water</li> </ul>	<ul style="list-style-type: none"> <li>· It needs to be checked with an assessment test.</li> <li>· An angled reservoir is required and water needs to be drawn out from the bottom of the reservoir.</li> </ul>
Poly-glycol	<ul style="list-style-type: none"> <li>· Low miscibility with mineral oil</li> <li>· Low self-absorbability because of high specific gravity (Density: 1.0 g/cm<sup>3</sup>@15 °C (59 °F))</li> <li>· Attention to suitability with rubber parts</li> </ul>	<ul style="list-style-type: none"> <li>· A standard needs to be set for an acceptable amount of residual oil.</li> <li>· The conditions of absorption need to be changed.</li> <li>· Good fluoride rubber or a rubber with low hardness stability in NBR fluid needs to be chosen.</li> </ul>

Source: Oil-Hydraulics Handbook (revised in 2001) by Japan Fluid Power Association.

### Reference (Method of assessment test of working fluid)

Following are assessment tests of anti-wear working fluid: first, the Falex Test observes the amount of abrasion caused by holding up and pressing a pin with two v-shaped blocks, and spinning it. Second, the Vickers Hardness Test measures the amount of abrasion of a vane and a cam ring after driving the system 100 hours at 2 000 psi, 1 200 r/min, and 65.6 °C (150 °F) or 79.4 °C (175 °F) with a Vickers 104C or 105C pump. Others include the Timken Test, the High-Speed Four-Ball Test, and Uni-Ball test.

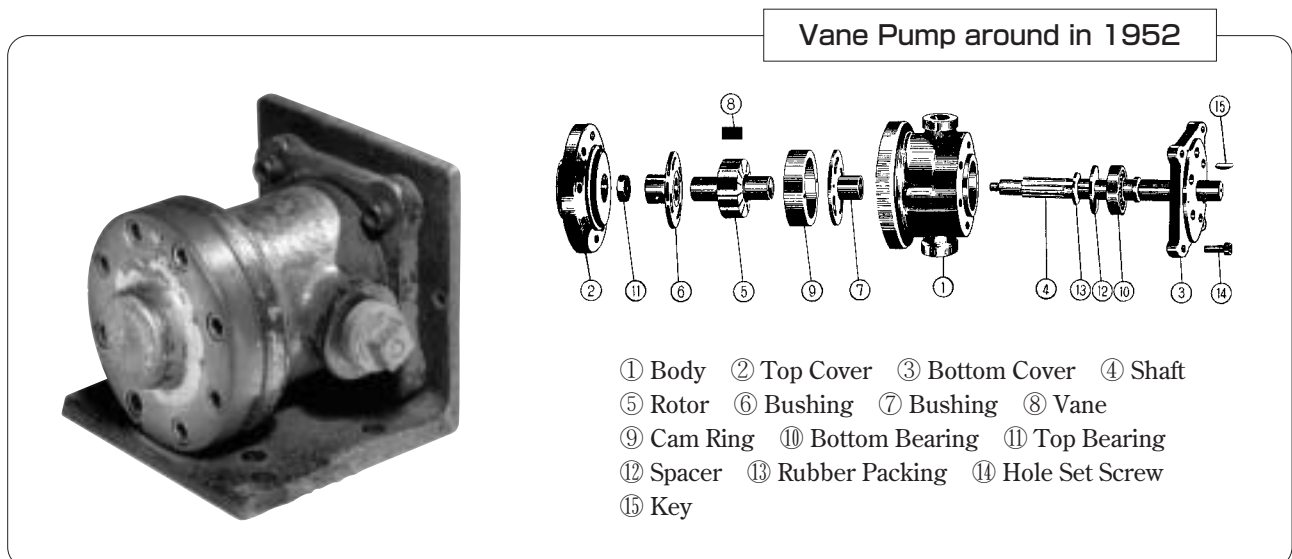

# 15

# HYDRAULIC CIRCUITS

- 15-1 Unload Circuits
- 15-2 Pressure Control Circuits
- 15-3 Speed Control Circuits
- 15-4 Filter Circuits
- 15-5 Synchronizing Circuits
- 15-6 Intensifying Circuits
- 15-7 Brake Circuits
- 15-8 Closed Circuits

Hydraulic circuits are composed of pumps, pressure control valves, directional valves, flow control valves, actuators and accessories, and change their compositions according to objectives and specifications. Many compositions are possible for a single objective. The most efficient circuit is:

- (1) Safe and completely optimal to meet objective.
- (2) Capable of smooth movement.
- (3) Energy efficient.
- (4) Effective for initial and running costs.
- (5) Easy to maintain.

The followings are general circuit examples (8 types, 29 examples).

## 15-1 Unload Circuits

These circuits enhance the product life and efficiency, at the same time, keeping the power consumption and heat generation at a low level when the system is in waiting mode. Hydraulic power is expressed in the following equation.

$$L \text{ (kW)} = \frac{PQ}{60}$$

P : Pressure (MPa)  
Q : Flow Rate (L/min)

$$L \text{ (HP)} = \frac{PQ}{1714}$$

P : Pressure (psi)  
Q : Flow Rate (U.S.GPM)

As shown, hydraulic power is proportional to the product of pressure and flow rate. Reducing either exponent then leads to lessened hydraulic power.

a) Open Center Circuit (Fig. 15.1 (a) (b))

Figure 15.1 (a) shows a circuit in which output flow from the pump is by-passed to the reservoir with the spool of the PT connection valve at the center position. In the case of solenoid pilot operated directional valves, as shown in Fig. 15.1 (b), the check valve is required to maintain the minimum pilot pressure of the valve.

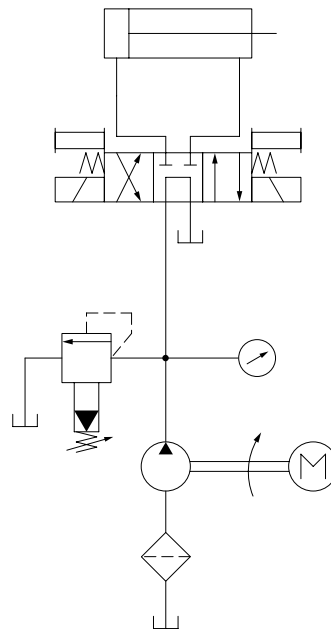

Fig. 15.1(a)

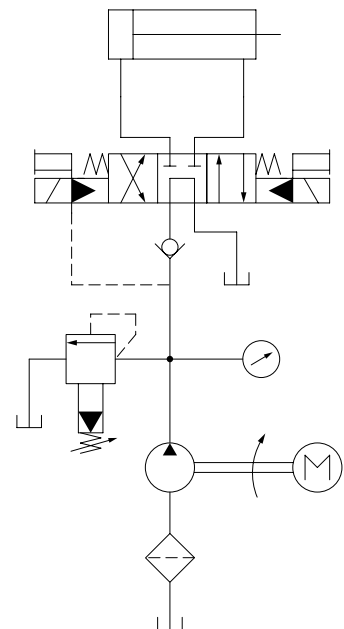

Fig. 15.1(b)

b) Circuit by Pressure Compensated Pump (Fig. 15.2)  
 This circuit reduces the amount of output flow rate by using the variable displacement pump with pressure compensating function. The pressure of the system is raised to a set level even when it is in idle.

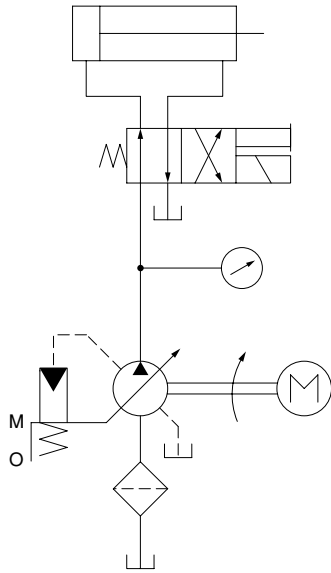

Fig. 15.2

d) Circuit with Accumulator (Fig. 15.4)  
 Pressure switch PS is correlated with the solenoid valve; when the circuit pressure equals the pressure set in the pressure switch PS, the solenoid valve is turned off, and output flow is by-passed to the reservoir, but the accumulator keeps the circuit pressure constant.

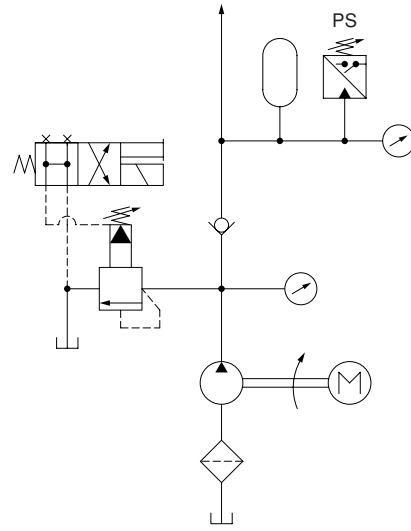

Fig. 15.4

c) Pump-Relief Unload Circuit (Fig. 15.3)  
 The circuit shown in Fig. 15.3 contains ① a low pressure and large volume pump and ② a high pressure and small volume pump. The circuit raises its efficiency by using ① and ②. In a case where the pressure in the circuit is lower than the pressure set at the unload valve, the output flow rate from ① and ② are gathered and provided to the circuit. In contrast, in a case where pressure in the circuit is higher than the pressure set at the unload valve, the output flow rate from ① is by-passed to the reservoir by the unload valve, and the pressure is unloaded. In this case, pressure within the circuit is kept at a certain level by the output flow rate from ② only. This circuit provides flow rate characteristics observed in a pressure vs. flow rate curve.

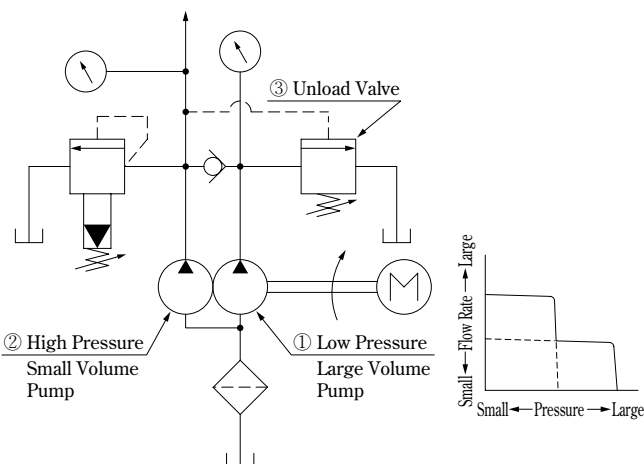

Fig. 15.3

e) Circuit with Two-Pressure Two-Control Type (Fig. 15.5)  
 When pump pressure is lower than PL, the angle of the swash plate becomes maximum, and the output flow reaches to the maximum (the flow rate goes to QH). In contrast, a pump pressure higher than PL causes a smaller swash plate angle and smaller output flow (QL). When the circuit pressure equals pump pressure, the swash plate angle falls close to zero, and output flow reduces to the amount of internal leakage. In this circuit, the power of the electric motor is kept small.

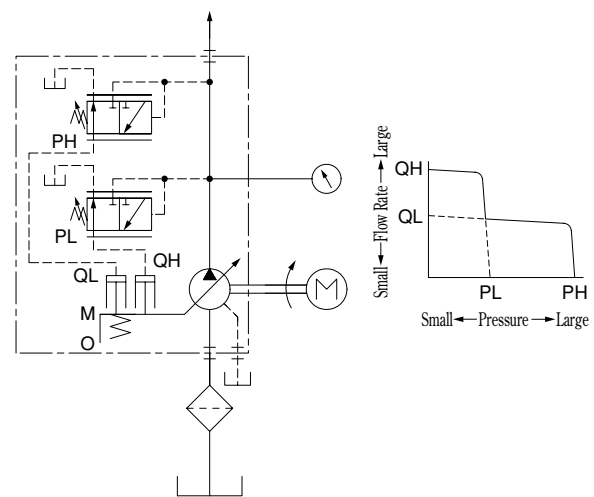

Fig. 15.5

## 15-2 Pressure Control Circuits

### a) Two-Pressure Circuit with Decompression and Check Valves (Fig. 15.6)

In the cylinder-forwarding process (solenoid OFF), circuit pressure is kept at 10 MPa (1 450 psi). But, in the cylinder-returning process (solenoid ON), circuit pressure is controlled at 7 MPa (1 015 psi) by the decompression valve.

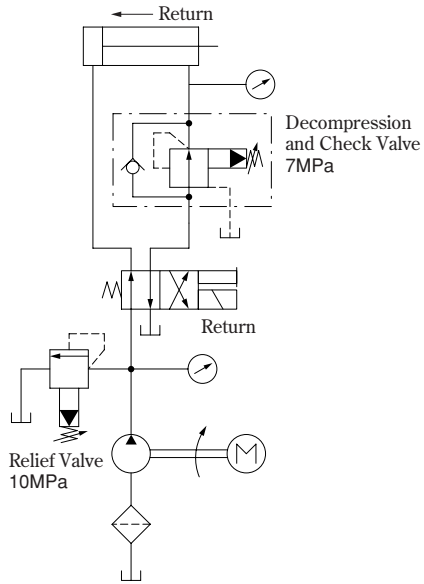

Fig. 15.6

### b) Decompression Circuit ① (Fig. 15.7)

Releasing compressed working fluid instantly back to a reservoir generates shock waves. Compressed working fluid must be released gradually. In Fig. 15.7, compressed working fluid in the cylinder cap is released gradually through the flow control valve. This reduces circuit pressure slowly, thus preventing shock waves.

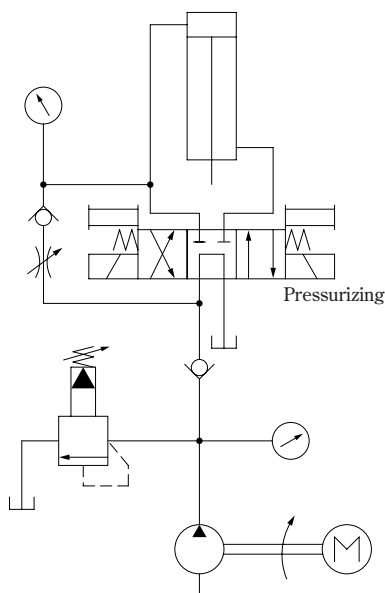

Fig. 15.7

### c) Decompression Circuit ② (Fig. 15.8)

After completion of pressure release, this circuit achieves automatic lift of the cylinder by electric signals from the pressure switch.

After compressing working fluid in the cylinder cap, the solenoid of the decompression valve is turned ON. Then, the compressed working fluid is released back to the reservoir through the flow control valve. Pressure in the circuit drops until it hits a certain point set in the switch PS. Then, the switch transmits signals out, and turns the solenoid valve ON to lift the cylinder. By this sequence, a smooth lift-up-and-down motion is achieved.

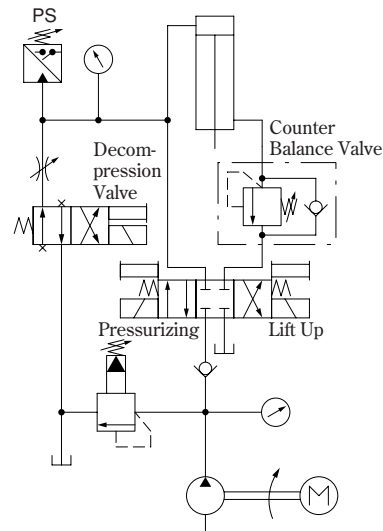

Fig. 15.8

### d) Weight Balancing Circuit (Fig. 15.9)

This circuit balances (holds up) the weight by using the balancing valve. The balancing valve cannot hold up the weight if the pump does not work and does not generate enough energy or pressure to hold up the weight. Therefore, a pilot operated check valve is commonly used in the circuit.

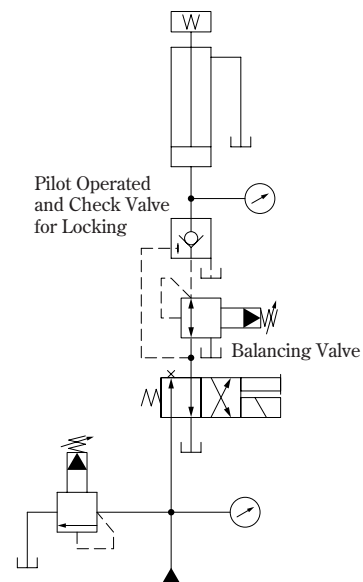

Fig. 15.9

## 15-3 Speed Control Circuits

### a-1) Speed Change Circuit (Fig. 15.10)

This circuit changes the speed of the cylinder motion by employing two flow control valves. Shifting to high speed, change over the solenoid operated directional valve for low speed first then change over the solenoid valve for high speed so that shock is kept small as shown in Table 15.1.

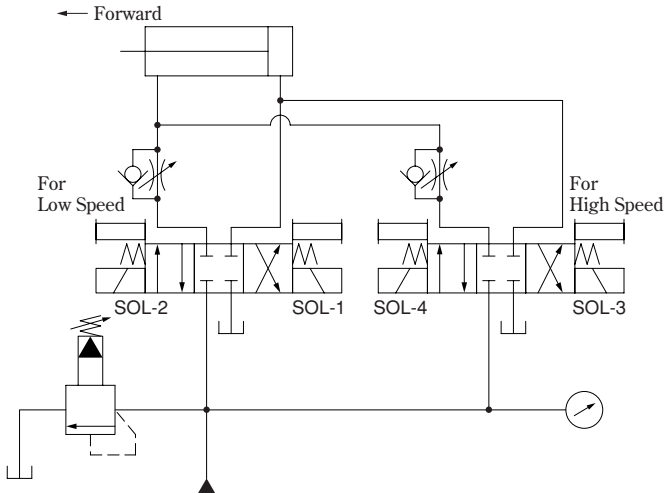

Fig. 15.10

Table 15.1 ON/OFF Change Pattern for Cylinder Forward Motion

Directional control valves	①	②
For Low Speed SOL-1	ON	ON
For High Speed SOL-3	OFF	ON

### a-2) Speed Change Circuit (Fig. 15.11)

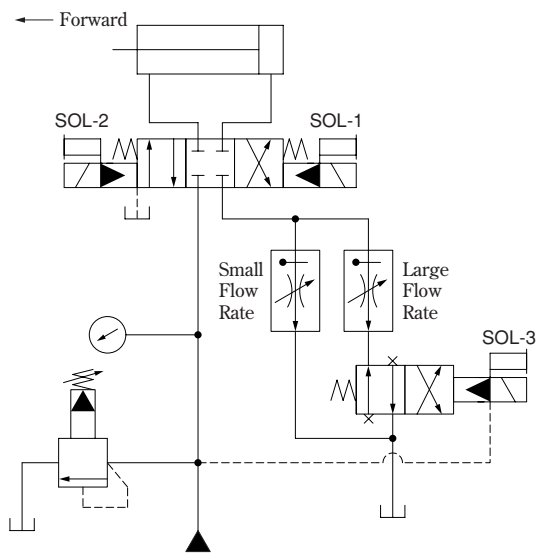

Fig. 15.11

### b) Circuit with Proportional Electro-Hydraulic Directional and Flow Control Valve (Fig. 15.12)

Optimal flow rate (speed) is achieved by controlling the amount of the spool shifted in the proportional electro-hydraulic valve; the spool is shifted proportional to the amount of electric signal received. The actuator is controlled smoothly with this valve, and the hydraulic circuit is simplified, as shown in Fig. 15.12.

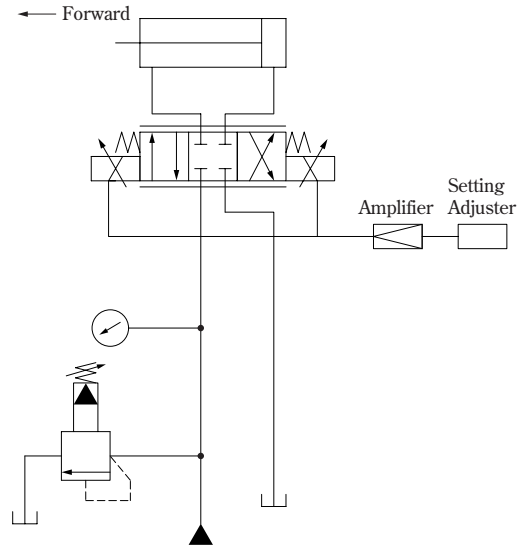

Fig. 15.12

### c) Differential Circuit

When the cylinder is pushed forward, working fluid discharged from the cylinder head is added back to the cylinder cap because of the difference in surface area between the cap and the head of the cylinder. This achieves a faster-cylinder-forward motion, compared to a circuit with only one channel of incoming flow.

$$V = \frac{\text{Pump Output Flow Rate}}{\text{Rod Area}} \quad F = \frac{\text{Pressure Supplied} \times \text{Rod Area}}{\text{Rod Area}}$$

The relationship between forward speed  $V$  and the rod area, and between output force  $F$  and the rod area, are obtained as follows.  $V$  and  $F$  are functions of the rod area. The size of load pressure and pressure loss require due attention.

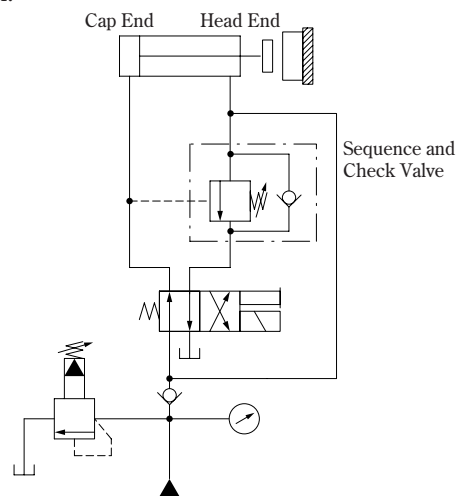

Fig. 15.13



d) Pre-Fill Valve Circuit (Fig. 15.14)

In this circuit, the subsidiary cylinders and the pre-fill valve help the main cylinder achieve pumping function. This circuit drastically reduces the pump-output volume required for the high-speed up-and-down cylinder motion of the press machine.

As the subsidiary cylinders move downward, the main cylinder is pulled down with them, sucking fluid from the reservoir through the pre-fill valve. At the end of the downward motion, the sequence valve is opened, and working fluid is directed to the main cylinder, which then generates a great pressure force on the press.

After the pressure is released, the solenoid valve is set for the high-speed upward motion. The main cylinder is pulled up again with the subsidiary cylinders, pushing fluid back to the reservoir through the pre-fill valve.

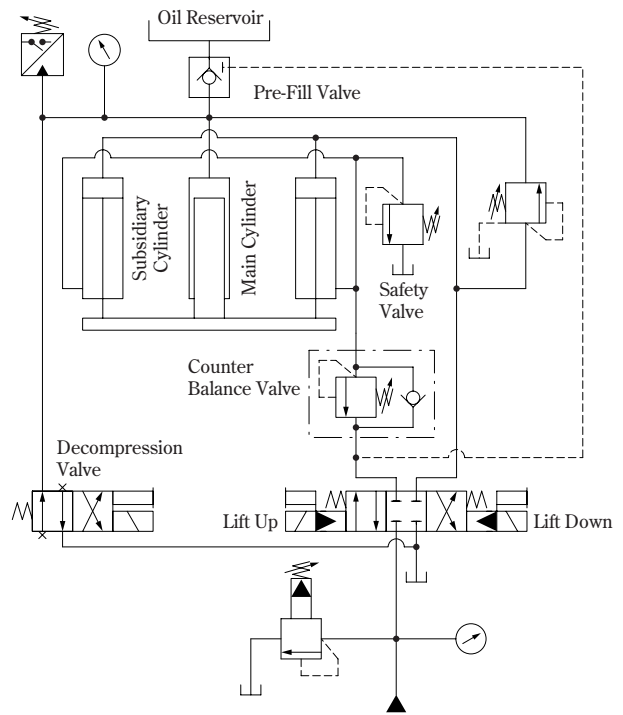

Fig. 15.14

15-4 Filter Circuits

Objectives of filtering and filtration rating change depending on where a filter is set in a circuit. One of the objectives, other than filtering contaminants is to let fluid flow at a certain rate. Another objective is to protect filter and provide a by-pass valve. Examples are shown in Fig. 15.15 to Fig. 15.17.

Figures 15.19 and 15.20 show circuits in which a clogged filter does not have an adverse impact. Also, filtration rating in these circuits can reach high class performance, (class 8 in the NAS Cleanliness Requirements with 1 pass quality.), when the ideal flow rate is applied to the filters.

a) Pump Filter Circuit (Fig. 15.15)

This circuit's objective is to protect the hydraulic pump. This circuit has two types: in one type, a filter is set inside a reservoir on a pump suction port (sometimes it is called a strainer), and in the other, a filter is set outside a reservoir to aid in maintenance. The filtration rates of these circuit types are limited to around 100  $\mu\text{m}$  because of the influence on pump suction resistance.

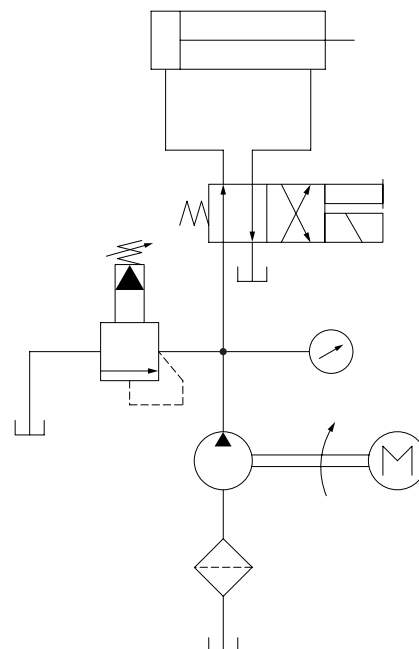

Fig. 15.15

b) Pressure Line Filter Circuit ① (Fig. 15.16)

This circuit protects the directional and other control valves in the line. Its filtration rate ranges from about  $10\ \mu\text{m}$  (solenoid/proportional valve) to  $3\ \mu\text{m}$  (servo valve, etc.).

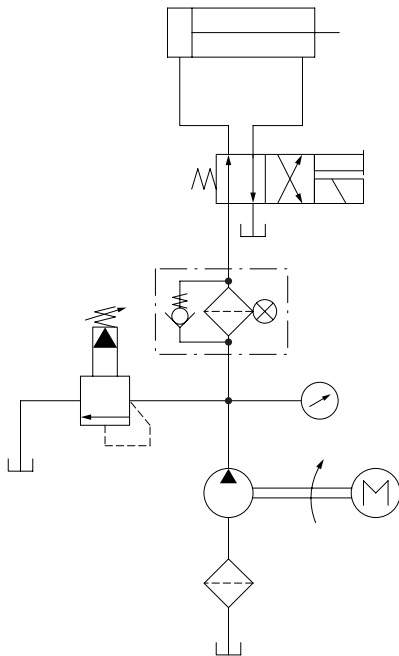

Fig. 15.16

c) Pressure Line Filter Circuit ② (Fig. 15.17)

This circuit has an objective similar to that of Fig. 15.16, but it filters out contaminants from the cylinder. It is better to filter out contaminants from only one direction with the anti-reverse-flow valve.

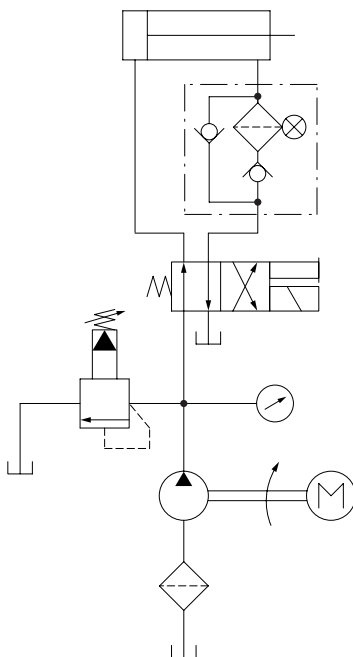

Fig. 15.17

d) Return Line Filter Circuit (Fig. 15.18)

This circuit filters working fluid going back to the reservoir. The filtration rate is approximately  $10\ \mu\text{m}$  to  $20\ \mu\text{m}$ .

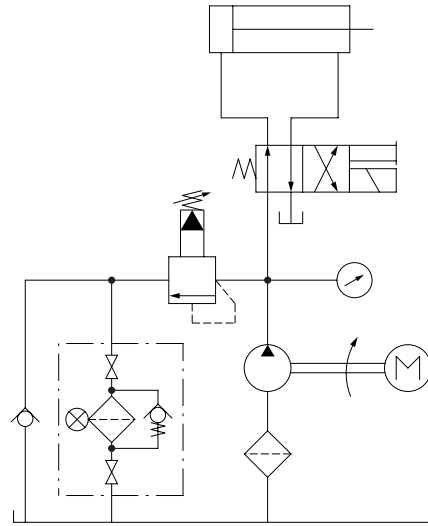

Fig. 15.18

e) Pressure Line Bleed-Off Filter Circuit (Fig. 15.19)

This circuit filters a small amount of the by-passed outlet flow from the pump (about 1 to 2 L/min (0.26~0.53 U.S.GPM)).

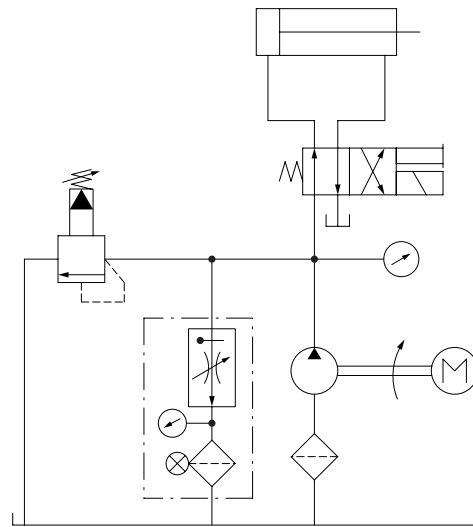

Fig. 15.19

f) Off-Line Filter Circuit (Fig. 15.20)

By using a pump and an electric motor specialized for filtration, this circuit filters contaminants even when the main hydraulic pump is not turned on. This circuit has the best filtration of all the filtration circuits.

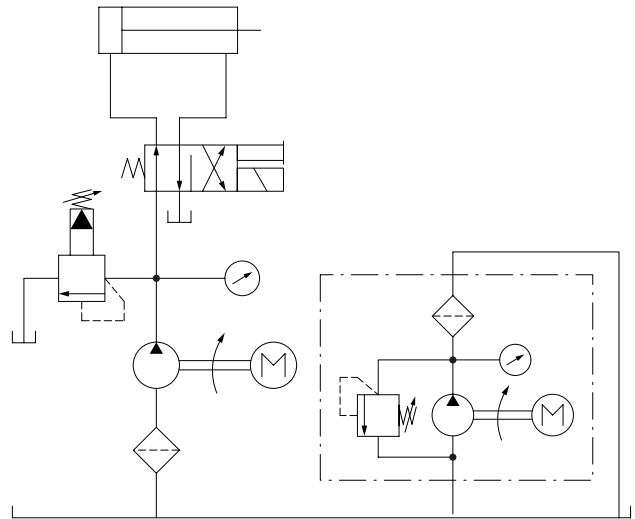

Fig. 15.20

15-5 Synchronizing Circuits

This circuit synchronizes movements of multiple actuators. Minimal error should never be overlooked, however, to avoid the accumulation of synchronization errors, it is always recommended that the circuit be set in such a way that the error is corrected at the end of an operation with one, full cylinder stroke, instead of the repeated, half-way cylinder motion.

a) Synchronizing Circuit with Mechanical Combination (Fig. 15.21)

This circuit realizes a synchronized motion by mechanically combined cylinder rods. In the following figure, the relationship between the two main cylinders and two other auxiliary cylinders is also a mechanical combination. This circuit does not necessitate a control valve for synchronization. Synchronization errors would be happened by production accuracy and rigid of mechanism.

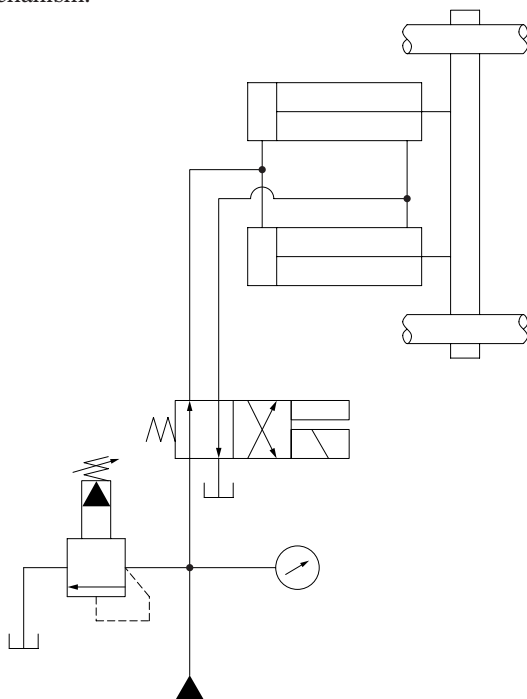

Fig. 15.21

b) Synchronizing Circuit with Flow Control Valves (Fig. 15.22)

In this circuit, the flow control valve controls fluid flowing in and out of the cylinders. Generally, a high accuracy valve is employed.

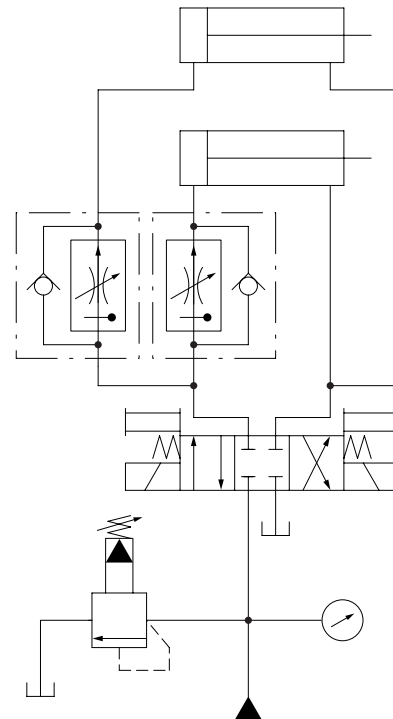

Fig. 15.22

c) Circuit with Flow Divider (Fig. 15.23)

This circuit utilizes the flow divider specialized for synchronization.

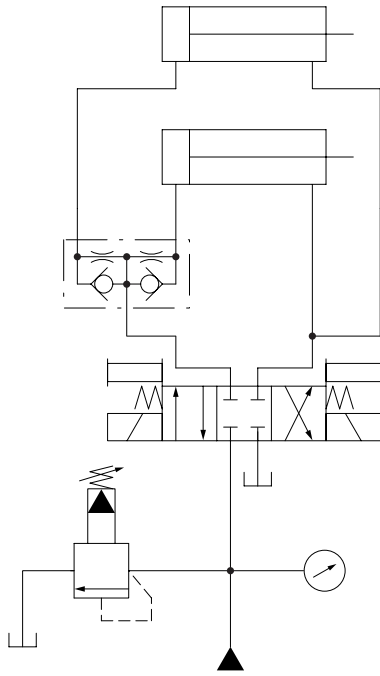

Fig. 15.23

d) Circuit with Synchronized Hydraulic Motors (Fig. 15.24)

With the shafts combined, these motors can displace the same amount of working fluid to and from each cylinder. The accuracy of the amount of displacement controls the accuracy of synchronization. Therefore, if the volumetric efficiency is the same, setting the circuit with high speed motors reduces synchronization errors.

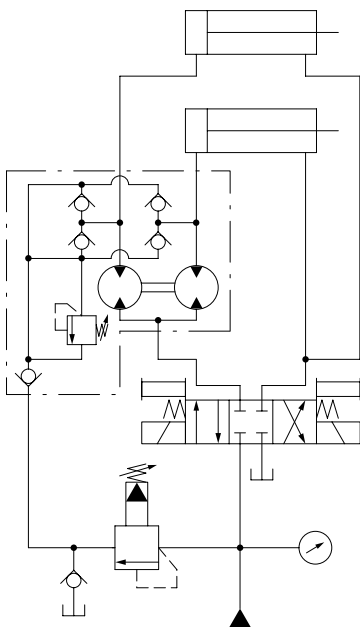

Fig. 15.24

e) Circuit with Synchronized Cylinders (Fig. 15.25)

This circuit realizes a very accurate synchronized motion via combined synchronizing cylinders. But, sometimes, spacing becomes an issue because it requires the volume of all the cylinders to be the same.

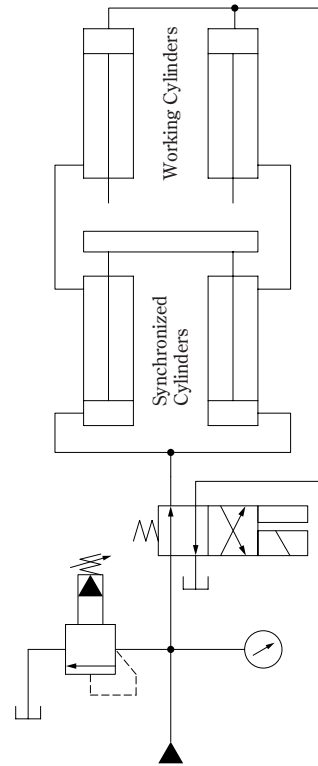

Fig. 15.25

f) Circuit with Servo Valve (Fig. 15.26)

This circuit detects the position of two cylinders and uses two servo valves to control the amount of working fluid required to adjust synchronization errors. The following figure is an example of such feedback-synchronization control. Rather than detecting the position of one cylinder, and giving the feedback to the other cylinder for synchronization, it is better and more accurate with less time lag if each cylinder works separately and their positions are controlled by different servo valves.

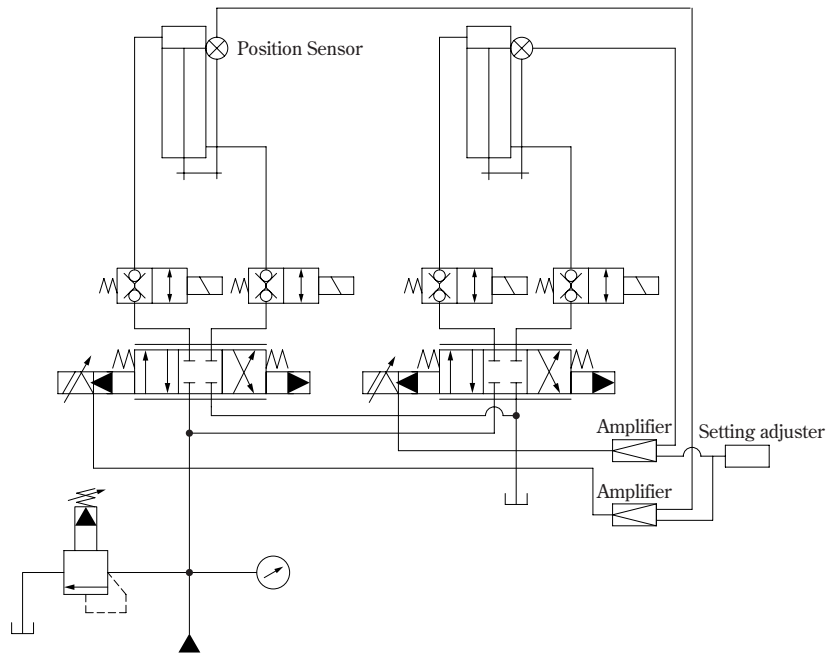

Fig. 15.26

### 15-6 Intensifying Circuits

#### Circuit with a Cylinder as Intensifier (Fig. 15.27)

This circuit intensifies pressure by using the difference between cap and head area in cylinders. In the following figure, the solenoid valve for adding pressure is turned ON. Working fluid channeled through the sequence valve ① pushes the working cylinder head forward until it hits an object. The contact between the cylinder head and the object eventually increases the pressure inside the line. Then, the circuit delivers the pressurized working fluid to the intensifying cylinder in which the fluid is pressurized yet further. The highly pressurized working fluid in the intensifying cylinder is then supplied back to the working cylinder. The decompression valve on the primary side of the intensifying cylinder adjusts the output power. Also, in the process of returning the cylinders, it is important to note that the intensifying cylinder is returned by the sequence valve ② (using the counter balance valve as the sequence valve).

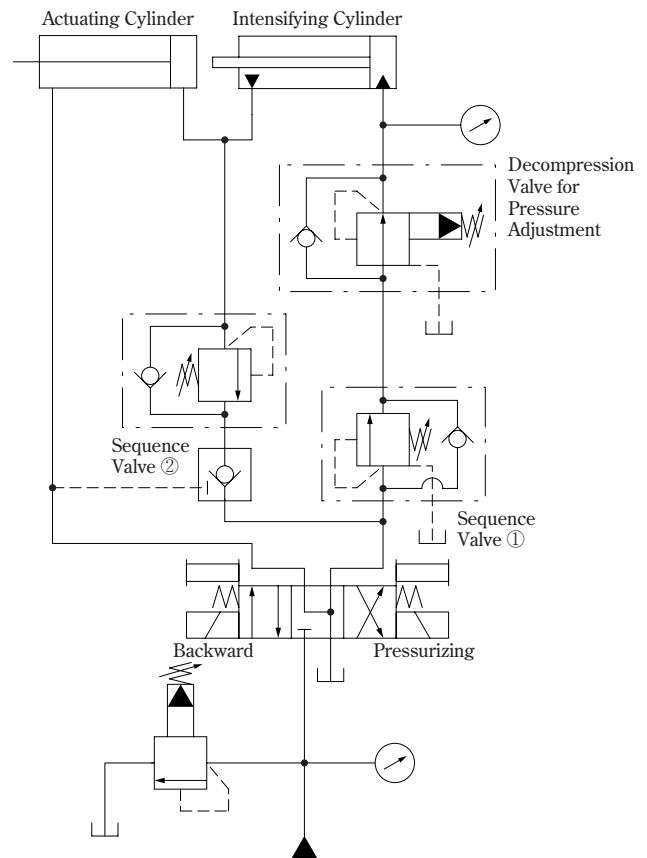

Fig. 15.27 Circuit with Intensifying Cylinders

## 15-7 Brake Circuits

### Brake Circuit with Hydraulic Motor (Fig. 15.28)

This figure is an example of a motor that turns both directions. With the solenoid valve in position ①, the hydraulic motor turns right. After that, the solenoid valve is in the middle position, but the hydraulic motor keeps working as a pump because of inertia. Discharged working fluid runs through the check valve ④, and returns to the reservoir with back pressure given by the relief valve. The primary side of the motor becomes low pressure, thus working fluid through the check valve ③ is supplied into the line. In the case of a left turn, the check valve ② and ⑤ are used.

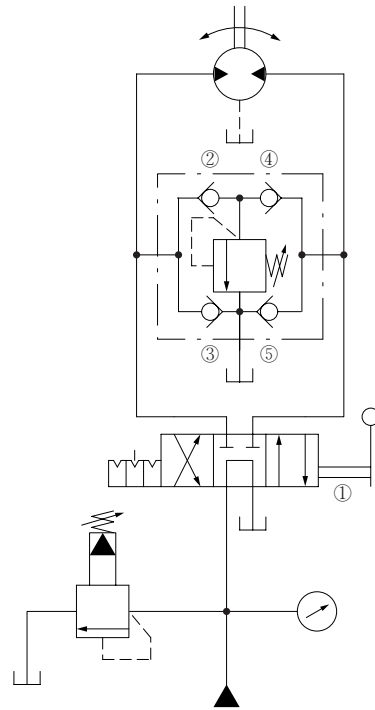

Fig. 15.28

## 15-8 Closed Circuits

### Closed Circuit for Vehicle (Fig. 15.29)

Closed circuits are widely employed in vehicles performing running, circling or HST (Hydro Static Transmission: no shift change for speed change) functions. One of the characteristics of this circuit is to use a pump as a hydraulic motor to absorb the power: this is a reverse use of the pumping function of a motor found in the previous section on brake circuits. In addition, pressure inside the line is low because the hydraulic pump controls the speed of the vehicle. This system is more efficient, and achieves less heat generation when compared to valve control systems. The feed pump fills and replaces working fluid internally, and it supplies clean fluid through a filter. The circuit must be made in such a way that safety valve ① has a higher pressure than that of safety valve ②, and that working fluid from the feed pump is discharged to the reservoir via the flushing valve.

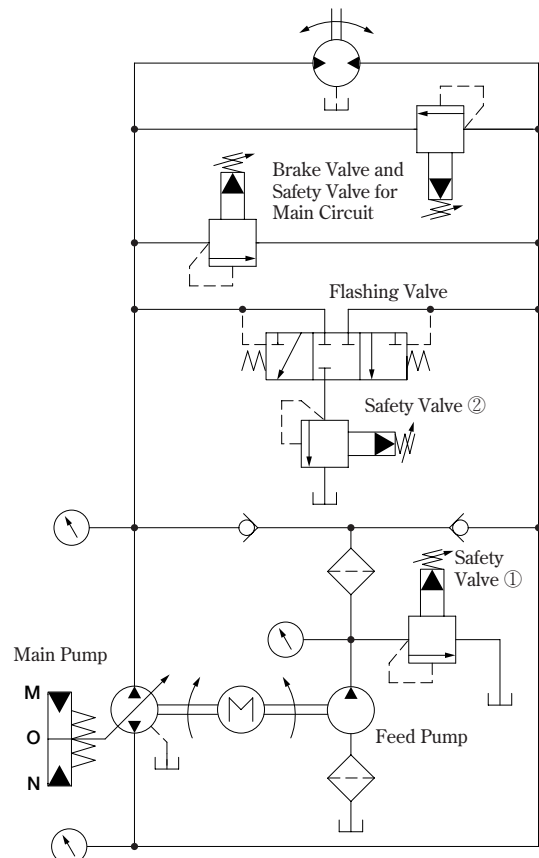
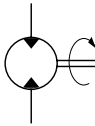

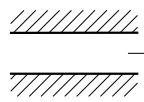
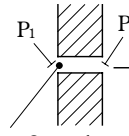

Fig. 15.29

Appendix: Main Formulas

	SI Unit	US Unit
Hydraulic Pumps	<p>● Hydraulic Power (Pump Output Power)</p> $L_o = \frac{P \cdot Q}{60}$ <p>                     L<sub>o</sub> : Hydraulic Power kW                      P : Pressure MPa                      Q : Flow Rate L/min                      ※ 1 kW = 1 kN·m/s = 60 kN·m/min                 </p>	$L_o = \frac{P \cdot Q}{1714}$ <p>                     L<sub>o</sub> : Hydraulic Power HP                      P : Pressure psi                      Q : Flow Rate U.S.GPM                 </p>
	<p>● Input Power</p> $L_i = \frac{2\pi TN}{60\,000}$ <p>                     L<sub>i</sub> : Input Power kW                      T : Shaft Torque N·m                      N : Rotation Speed r/min                 </p>	$L_i = \frac{T \cdot N}{5\,252}$ <p>                     L<sub>i</sub> : Input Power HP                      T : Shaft Torque lbf·ft                      N : Rotation Speed r/min                 </p>
	<p>● Volumetric Efficiency</p> $\eta_v = \frac{Q_p}{Q_o} \times 100$ <p>                     η<sub>v</sub> : Overall Efficiency %                      Q<sub>p</sub> : Output Flow Rate at Pressure P L/min (U.S.GPM)                      Q<sub>o</sub> : Output Flow Rate at No pressure L/min (U.S.GPM)                      ※ Q<sub>o</sub> - Q<sub>p</sub> = Total Leakage Amount at Pump Inside                 </p>	
	<p>● Overall Efficiency</p> $\eta = \frac{L_o}{L_i} \times 100 = \frac{P \cdot Q}{60 L_i} \times 100$ <p>                     η : Overall Efficiency %                      L<sub>o</sub> : Hydraulic Power kW                      L<sub>i</sub> : Input Power kW                      P : Output Pressure MPa                      Q : Output Flow Rate L/min                 </p>	$\eta = \frac{L_o}{L_i} \times 100 = \frac{P \cdot Q}{1714 L_i} \times 100$ <p>                     η : Overall Efficiency %                      L<sub>o</sub> : Hydraulic Power HP                      L<sub>i</sub> : Input Power HP                      P : Output Pressure psi                      Q : Output Flow Rate U.S.GPM                 </p>
<p>● Output Power of Hydraulic Motor</p>  $L = \frac{2\pi T \cdot N}{60\,000}$ <p>                     L : Output Power kW                      T : Torque Nm                      N : Rotation Speed r/min                 </p>	$L = \frac{T \cdot N}{5\,252}$ <p>                     L : Output Power HP                      T : Torque lbf·ft                      N : Rotation Speed r/min                 </p>	
<p>● Cylinder Output Power</p>  $L = \frac{F \cdot V}{60}$ <p>                     L : Output Power kW                      F : Thrust kN                      V : Speed m/min                 </p>	$L = \frac{F \cdot V}{33\,000}$ <p>                     L : Output Power HP                      F : Thrust lbf                      V : Speed ft/min                 </p>	
<p>● Power Loss of a Valve</p> <p>Flow Rate : Q</p> <p>Pressure : P<sub>1</sub>      Pressure : P<sub>2</sub></p>  <p>Pressure Loss : ΔP = P<sub>1</sub> - P<sub>2</sub></p> <p>Power Loss at Valve Inlet/Outlet : L</p>	$L = \frac{\Delta P \cdot Q}{60}$ <p>                     L : kW                      ΔP : MPa                      Q : L/min                 </p>	$L = \frac{\Delta P \cdot Q}{1714}$ <p>                     L : HP                      ΔP : psi                      Q : U.S.GPM                 </p>
<p>● Viscosity (Absolute Viscosity) and Kinematic Viscosity</p>	$\mu = \rho \cdot \nu_1 = \rho \cdot \nu_2 \times 10^{-6}$ <p>                     μ : Viscosity (Absolute Viscosity) Pa·s (=N·s/m<sup>2</sup>)                      ρ : Density kg/m<sup>3</sup>                      ν<sub>1</sub> : Kinematic Viscosity m<sup>2</sup>/s                      ν<sub>2</sub> : Kinematic Viscosity mm<sup>2</sup>/s                 </p>	
<p>● Reynolds Number</p> <p>Diameter : d</p>  <p>Velocity : V Flow Rate : Q</p> <p>R : Reynolds Number ν : Kinematic Viscosity</p>	$R = \frac{V \cdot d}{\nu_1} = \frac{4\,000 Q}{60 \pi d \cdot \nu_1} = \frac{2\,120 Q}{d \cdot \nu_2}$	<p>                     R : Dimensionless                      V : cm/s                      d : cm                      ν<sub>1</sub> : cm<sup>2</sup>/s                      ν<sub>2</sub> : mm<sup>2</sup>/s {cSt}                      Q : L/min                 </p> <p>                     ※ R &lt; 2 300 ..... Laminar Flow                      R &gt; 2 300 ..... Turbulent Flow                 </p>
<p>● Flow of Orifice</p>  <p>                     P<sub>1</sub>      P<sub>2</sub>                      Q                      A : Open Area                      ΔP = P<sub>1</sub> - P<sub>2</sub>                      C = Flow Rate Index                      γ = Specific Weight                      ρ = Density                 </p>	$Q = C \cdot A \sqrt{\frac{2\Delta P}{\rho}} \times 10^6 \times 6$ <p>                     Q : L/min      ρ : kg/m<sup>3</sup>                      C : Dimensionless      ΔP : MPa                      A : cm<sup>2</sup> </p>	$Q = C \cdot A \sqrt{\frac{2g}{\gamma} \Delta P}$ <p>                     Q : in<sup>3</sup>/s      g : 386.4 in/s<sup>2</sup>                      C : Dimensionless      γ : lbf/in<sup>3</sup>                      A : in<sup>2</sup>      ΔP : psi                 </p>
<p>Note) Flow rate index is affected by forms of flow lines and Reynolds number, and is usually about 0.6 to 0.9.</p>		



## **BASIC HYDRAULICS AND COMPONENTS**

Mar. 2006

(Original Japanese edition Pub.JS-100-2 : Jan. 2005)

---

●Published by:

Yuken Kogyo Co., Ltd.  
Sales Department, Advertisement Section  
Hamamatsucho Seiwa Bldg., 4-8,  
Shiba-Daimon 1-Chome, Minato-ku, Tokyo  
105-0012 JAPAN  
TEL. +81-3-3432-2113  
FAX. +81-3-3436-2344

●Printed by:

See the reference code on the back cover.  
Please address your inquiries regarding this book  
to Overseas Business Department.

●Production assistance by:

Kevin Hagen