

# FLOW MEASUREMENT TECHNOLOGY

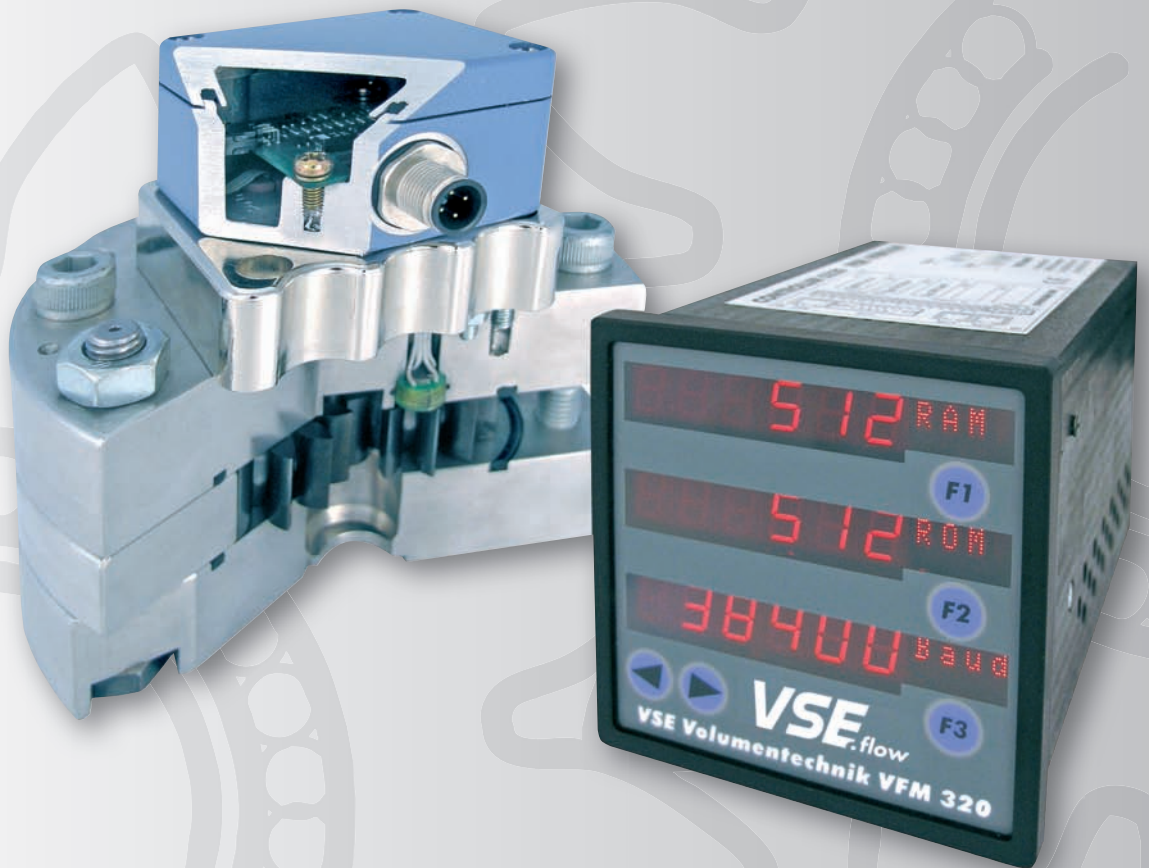

**VS SERIES**



## ► VS POSITIVE DISPLACEMENT FLOW METERS

### VS FLOW METER

- VS positive displacement flow meters are volume rate measuring sensors based on the meshing gear principle and are designed for use with liquids. Two precisely matched gear wheels are enclosed in a very accurately machined housing. Gear rotation is sensed by a non-contacting signal pick-up system. Each tooth produces one impulse.

- The space between the gear teeth, when fully enclosed on both sides by the housing, constitutes measuring chambers. Fluid flow causes the gears to rotate and the incoming flow is separated into discrete volumes within these chambers i. e. the volume of liquid passing through the unit will cause rotation of the gears by exactly one tooth pitch.

- This volume is known as the Volume/Impulse ( $V_m$ ) and is stated in cc/Imp. It is used to define the size of a flow meter.

### EXPLANATIONS OF PREAMPLIFIER OF SIGNAL PICK-UP SYSTEM

- The non-contact pick-up sensors consist of two differential magneto resistors, which are circumferentially offset from one another by 1/4 of a tooth pitch. The signals of both pick-up sensors are digitised with two signal amplifiers and amplified via followed shortcircuit proof push-pull output stages.

The square wave output signals are bidirectional and may be simply processed by any external electronics, plc control or computer. The processing of the 90° phase angle between signals enables recognition of flow direction and impulse rate conversion with a factor of 1, 2 and 4.

- The signal frequency is proportional to the momentary flow rate (volume rate) dependent on the particular flow meter size. The frequency range extends from 0 - 2000 Hz. The preamplifier is protected against reverse polarity and incorrect connection. For medium temperatures between -40° C and 120° C (-22° F and 248° F) the unit is mounted directly on the flow meter cover.

### SENSOR SYSTEMS FOR EXTENDED TEMPERATURE RANGE

- For liquid temperatures up to 210° C (410° F) a special pick up system is available.

### VSI-HIGH DEFINITION PREAMPLIFIER

- The VSI High Definition Preamplifier supplies digital signals with a higher resolution of the measured value. The resolution can be programmed between 4 and 64 angle steps and it enables a frequency multiplication up to factor 16. The K-factor of the flow meter can be increased up to factor 64. The maximum frequency at full flow can be 26 kHz.

### EX-TYPES

- Intrinsically safe models, with approval code  I 1G EEx ia IIC T4-T6, are supplied for applications in potentially explosion-hazardous areas. VSE delivers these types with isolation switch amplifier models MK 13 P Ex Ex0/21 VDC/K15.

### VS FLOW METER SELECTION

- For trouble-free and safe operation of the flow meters the correct selection of type and size is decisive. Due to the great number of different applications and flow meter versions, the technical data in the VSE-catalogues are of general character. Certain characteristic of the devices depend on type, size and measuring range as well as on the medium to be measured. For exact flow meter selection please contact VSE.

## OUTPUT SIGNALS OF PREAMPLIFIER

### FLOW METER VS 0,02... VS 4

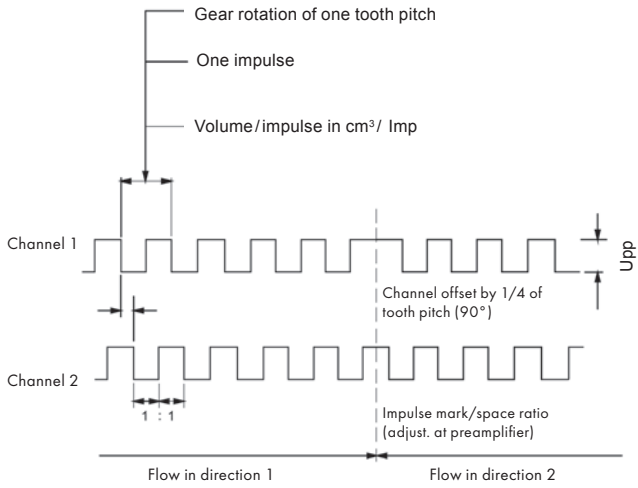

#### \* VOLTAGE RANGES

Supply voltages:  $U_v = 10 \dots 28 \text{ V DC}$   
 Impulse voltages:  $U_{pp} = U_v - 1 \text{ V}$

### FLOW METER VS 10

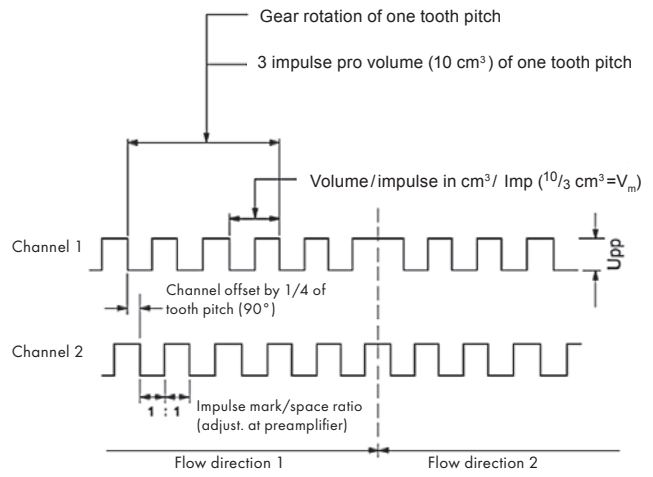

#### \* VOLTAGE RANGES

Supply voltages:  $U_v = 10 \dots 28 \text{ V DC}$   
 Impulse voltages:  $U_{pp} = U_v - 1 \text{ V}$

## BLOCK DIAGRAM

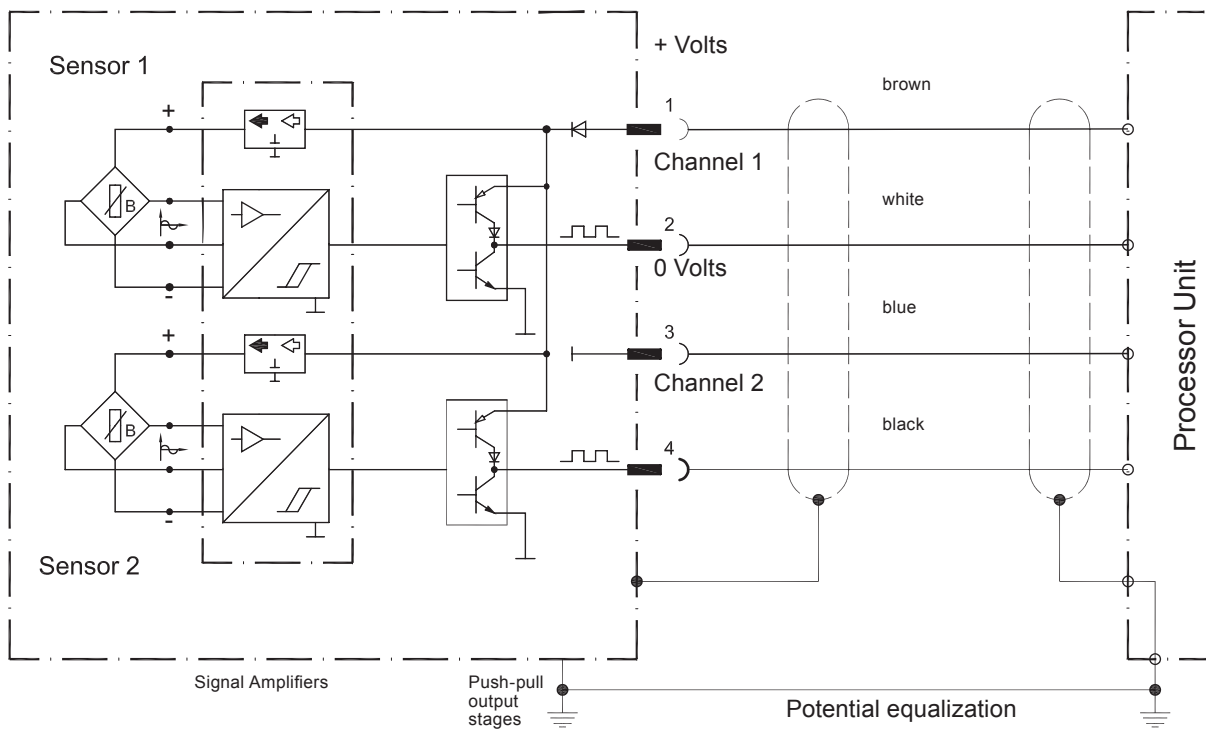

## ► RANGES OF APPLICATIONS

### APPLICATIONS

• All liquids that can be pumped and have known lubrication properties can be measured, for example: petrol, paraffin, kerosene, diesel, Skydrol, mineral oils, hydraulic oils including fire resistant fluids, inks, dyes and paints, greases, polyurethane, polyol and isocyanates, Araldite, glues, pastes and creams, resins, waxes ... and many others.

### RANGES OF APPLICATIONS IN THE AUTOMOTIVE INDUSTRY

- Braking system test stands
- Fuel consumption measurement
- Polyurethane foams for steering wheels, fascia, seats etc.
- Paint spraying systems
- Steering systems
- Batching and filling of motor oils, brake fluids, anti-freeze, corrosion preventatives, waxes etc.
- Adhesive coatings for windscreens, headlights, engine housings etc.

### HYDRAULICS

- Volume and flow rate measurement
- Leakage and rupture monitoring
- Cylinder speed and position measurement
- Positioning and step control
- Measurement, control and regulation of flow rates and volumes
- Test stands for pumps, motors, valves, proportionals and servo-valves
- Synchronised multi-cylinder monitoring
- Filling and additive blending

### DYES AND PAINTS

- Paint spraying systems
- Batching and filling
- Volume, flow rate and consumption
- Monitoring of mixing ratios

### PLASTICS TECHNOLOGY

- Mixing, moulding and batching systems for single and multicomponent fluidplastics
- Consumption measurement of e.g.: Epoxy adhesives and potting compounds (resins and hardeners) for transformers, coils, relays, condensers, armatures, initiators, auto-electronics
- Measuring, control and regulation of single components and mixing ratios
- Silicon potting compounds
- Polyurethane foams (polyol and isocyanate) for steering wheels, seals, shoes, soles, surf boards, furniture, computer casings, isolation etc.
- hot adhesive

### CHEMICAL INDUSTRY

- Flow rate and volume measurement in process plant and plant systems
- Blending and filling chemical products such as liquid plastics adhesives, resins, hardeners, potting, compounds, solvents, fuels, foames plasticisers, dyes and paints, oils and synthetic products etc. application in laboratories and manufacturing plants (in normal and explosion-hazardous areas)
- Control and regulation of single components, mixing ratios and consumption of various components
- Leakage measurement and leakage monitoring on plant
- Measurement, indication and logging of data for product quality assurance

### SPECIAL DESIGNS ON REQUEST

The issue of this catalogue invalidates all specifications in earlier publications. Changes and deviations are reserved by VSE. VSE will not accept liability for printing errors. Reproduction, including excerpts, is only permitted with written permission by VSE. Revision: 05/2010

► **TECHNICAL DATA OVERVIEW**

Size	Flow Range*	Flow Range*	K-Factor	K-Factor
	l/min	GPM	Imp./l	Imp./Gal.
VS 0.02	0.002 ..... 2	0.0005 ..... 0.53	50 000	189272
VS 0.04	0.004 ..... 4	0.0011 ..... 1.06	25 000	94636
VS 0.1	0.01 ..... 10	0.0026 ..... 2.64	10 000	37854.4
VS 0.2	0.02 ..... 18	0.0053 ..... 4.76	5 000	18927.2
VS 0.4	0.03 ..... 40	0.0079 ..... 10.57	2 500	9463.6
VS 1	0.05 ..... 80	0.0132 ..... 21.13	1 000	3785.44
VS 2	0.1 ..... 120	0.0264 ..... 31.70	500	1892.72
VS 4	1 ..... 250	0.2642 ..... 66.00	250	946.36
VS 10**	1.5 ..... 525	0.39 ..... 138.00	300	1135
	<b>*at 21 cSt</b>	<b>*at 21 cSt</b>		

**CALCULATION FACTOR**

- 1 litre = 0.26417 U.S. Gallon
- 1 U.S. Gallon = 3.78544 litre
- 1 bar = 14.503684 psi
- 1 psi = 0.068948 bar

$$^{\circ}\text{C} = \frac{5 \times (^{\circ}\text{F} - 32)}{9} \quad \text{psi} = \text{pound-weight per square inch}$$

$$^{\circ}\text{F} = \frac{9}{5} \times ^{\circ}\text{C} + 32 \quad \text{GPM} = \text{U.S. Gallon per minute}$$

<b>Accuracy</b>	± 0.3 % of measured value at viscosity > 20 cSt (< 20 cSt reduced accuracy)		
<b>Repeatability</b>	± 0.05 % under same operating conditions		
<b>Materials</b>	<b>Body</b> EN-GJS-400-15 (EN 1563) Stainless Steel 1.4305	<b>Bearings</b> Ball/Plain/Plain (Copper-free) depend on liquid.	<b>Seals</b> FPM (Standard) NBR, PTFE, EPDM
<b>Max. Operating Pressures</b>	<b>Cast Iron</b> 315 bar/4568 psi	<b>Stainless Steel</b> 450 bar / 6526 psi	
<b>Medium Temperature</b>	Standard Ex-design High temperature	-40 ≤ ... 120° C -20 ≤ ... 100° C -40 ≤ ... 210° C	
<b>Viscosity Ranges</b>	1...100 000 cSt		
<b>Mounting Positions</b>	unrestricted, on subplate with side or bottom connections		
<b>Filtering for ball bearing type</b>	VS 0.02/0.04/0.1    10 µm VS 0.2/0.4            20 µm VS 1/2                    50 µm VS 4                        50 µm	<b>Exceptions</b> flow meter with special clearance on request.	
<b>Noise Level</b>	max. 72 dB(A)		
<b>Preamplifier</b>	10 to 28 Volt (DC)		

**▶ FLOW RESPONSE CURVES**

**VS 0.02**

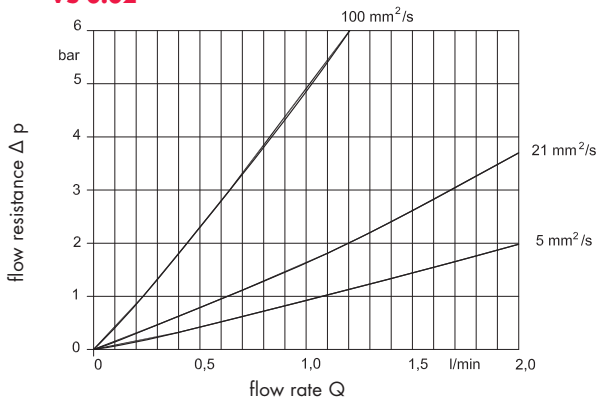

**VS 0.04**

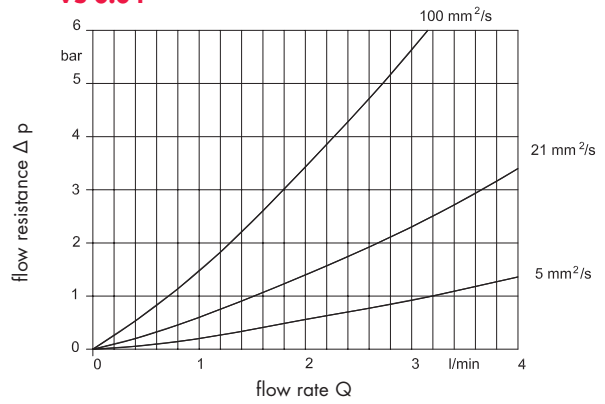

**VS 0.1**

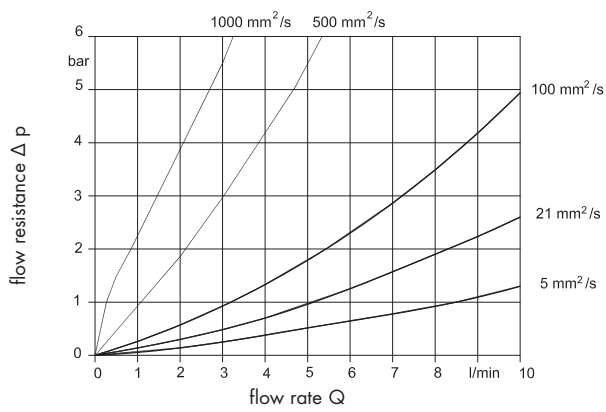

**VS 0.2**

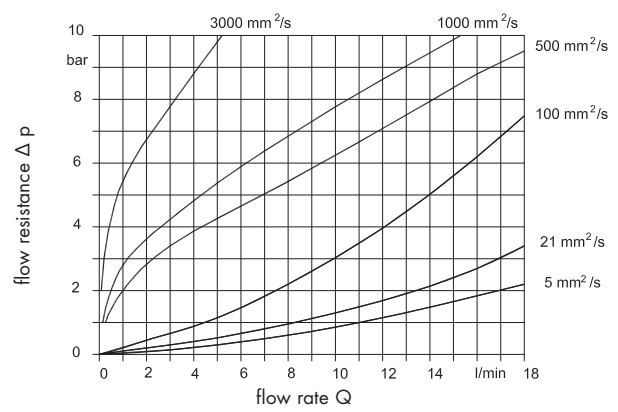

**VS 0.4**

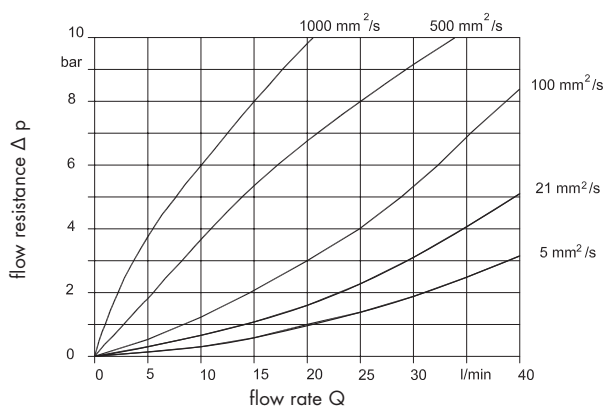

**VS 1**

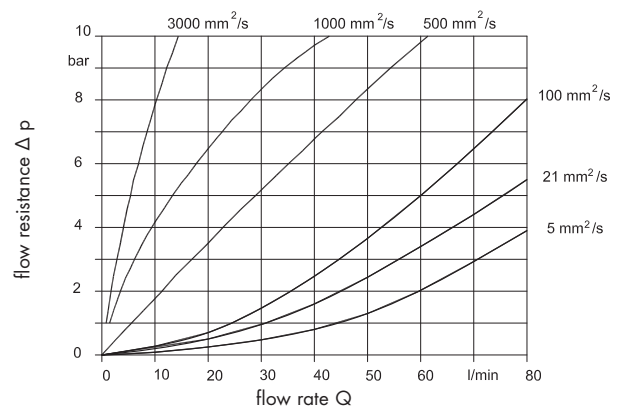

**VS 2**

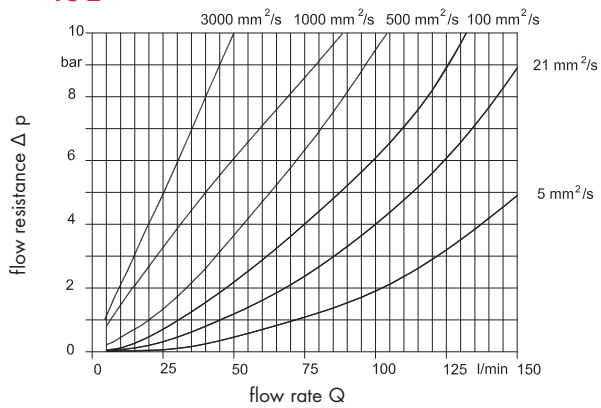

**VS 4**

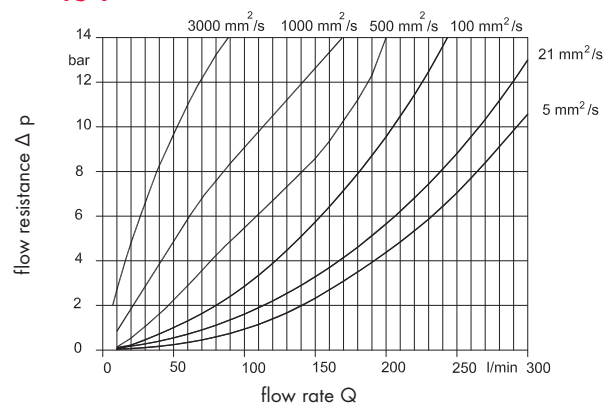

## ► VS FLOW METER DIMENSIONS

### CAST IRON VERSION

- Housing curve mill cutted

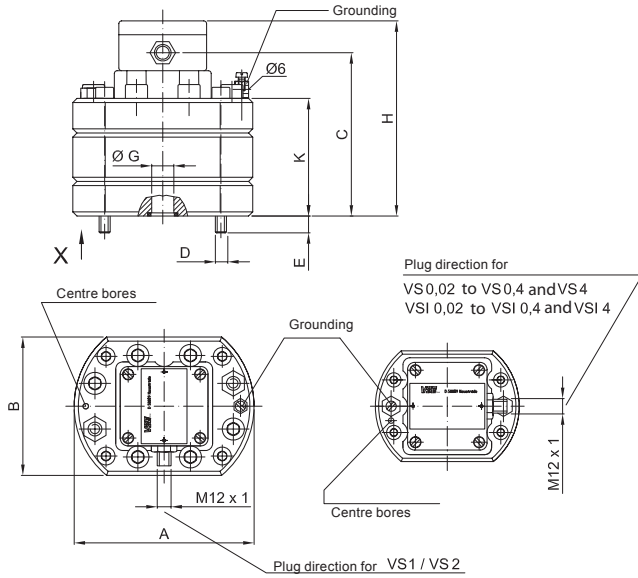

### CAST IRON VERSION CONNECTION DRAWING

- View X

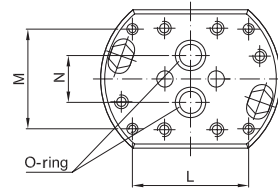

### STAINLESS STEEL VERSION CONNECTION DRAWING

- Housing not mill cutted
- View X

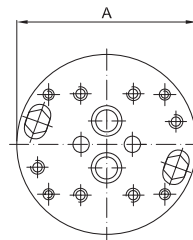

Size VS / VSI	A	B	C	D	E	ø G	H	K	L	M	N	O-ring	Weight	
													GG*	E*
													kg	kg
<b>0.02</b>	100	80	91	M 6	12	ø 9	114	58	70	40	20	11 x 2	2.8	3.4
<b>0.04</b>	100	80	91.5	M 6	11.5	ø 9	114.5	58.5	70	40	20	11 x 2	2.8	3.4
<b>0.1</b>	100	80	94	M 6	9	ø 9	117	61	70	40	20	11 x 2	2.8	3.4
<b>0.2</b>	100	80	93.5	M 6	9.5	ø 9	116.5	60.5	70	40	20	11 x 2	3.0	3.7
<b>0.4</b>	115	90	96.5	M 8	11.5	ø 16	119.5	63.5	80	38	34	17.96 x 2.62	4.0	5.0
<b>1</b>	130	100	101	M 8	12	ø 16	124	68	84	72	34	17.96 x 2.62	5.3	6.8
<b>2</b>	130	100	118	M 8	15	ø 16	141	85	84	72	34	17.96 x 2.62	6.7	8.4
<b>4</b>	180	140	143	M 12	20	ø 30	166	110	46	95	45	36.17 x 2.62	14.7	18.4

\* GG = Cast Iron EN-GJS-400-15 (EN 1563)

\* E = Stainless Steel 1.4305

Dimensions are specified in mm

### SIDE PORTS

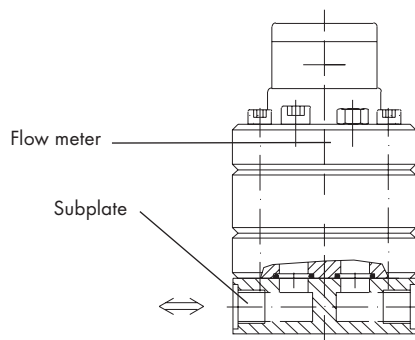

### BOTTOM PORTS

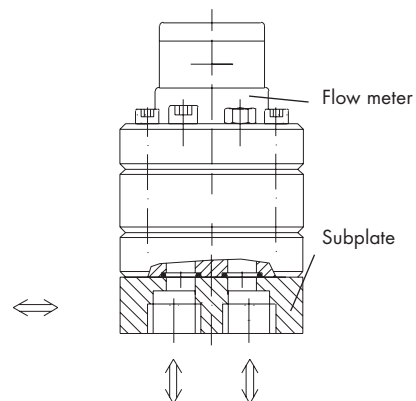

## ▶ AP SUBPLATE DIMENSIONS

### SIDE PORTS

### BOTTOM PORTS \*

Cast Iron / APG.S.../.

Stainless Steel / APE.S.../.

Cast Iron / APG.U.../.

Stainless Steel / APE.U.../.

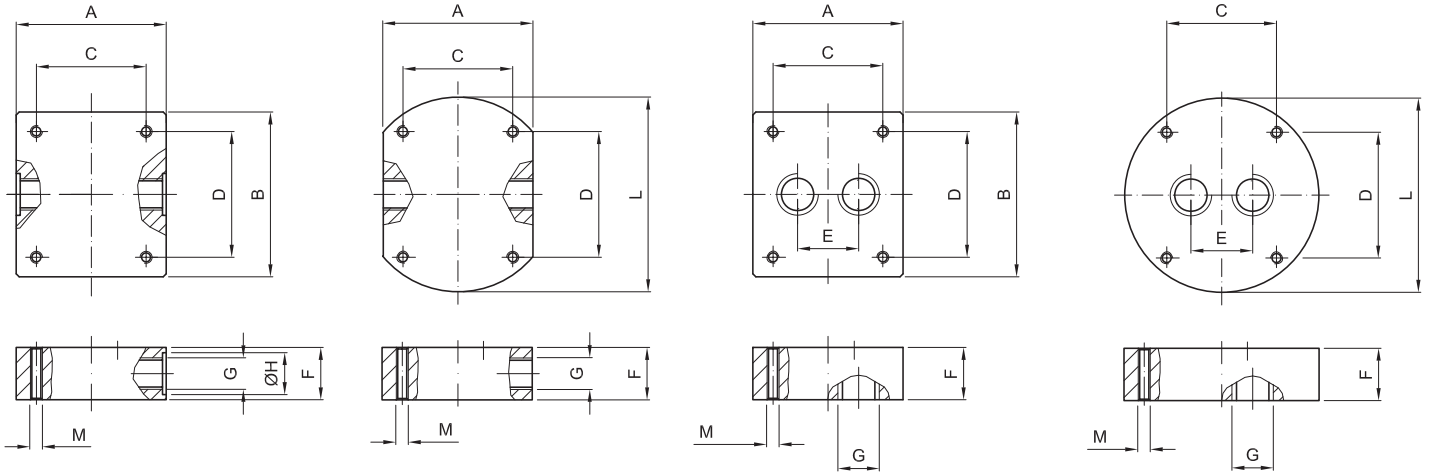

\* Both bottom ports (G) for size APG 4 U and APE 4 U have a displacement of 90° to the shown drawings.

AFFILIATED SIZE	VS / VSI	G PIPE THREAD CLASSIFICATION	G	F	Ø H	E ①
	0.02 / 0.04			G 1 / 4	35	Ø 20
0.1 / 0.2						
0.02 / 0.04			G 3 / 8	35	Ø 23	30
0.1 / 0.2						
0.02 / 0.04			G 1 / 2	35	Ø 28	38
0.1 / 0.2						
0.4 / 1 / 2			G 1 / 2	35	Ø 28	46
0.4 / 1 / 2			G 3 / 4	40	Ø 33	52
1 / 2			G 1"	55	Ø 41	55
4			G 1 1 / 4	70	Ø 51	60
4			G 1 1 / 2	AP.U=70	Ø 56	72
4			G 1 1 / 2	AP.S=80	Ø 56	72

Size							Depth	Weight
VS / VSI	AP	A	B	C	D	L ②	M	kg
<b>0.02/0.04</b>	AP.02	80	90	40	70	100	M6/12	1.8
<b>0.1/0.2</b>								
<b>0.4</b>	AP.04	90	100	38	80	115	M8/15	2.7
<b>1/2</b>	AP.1	100	110	72	84	130	M8/15	3.6
<b>4</b>	APG4	120	130	100	110	-	M8/15	7.4
	APG4 UG	140	120	120	100	-	M8/15	7.4
	APE.4	140	-	100	110	180	M8/15	12

① Only for APG.U .../ . ; APE.U .../ .

② Only for APE.S .../ . ; APE.U .../ .

Special designs on request



## ► VS 10 FLOW METER

### TECHNICAL DATA

Size	Flow range l/min	GPM	K-Factor Imp./l	Imp./Gal.
VS 10	1.5 ... 525	0.3963 ... 138.69	300	1135.63

<b>Accuracy</b>	± 0.3 % of measured value at viscosity > 20 cSt (< 20 cSt reduced accuracy)		
<b>Repeatability</b>	± 0.05 % under same operating conditions		
<b>Materials</b>	Body	Bearings	Seals
	EN-GJS-600-3 EN 1563	Ball/Plain gearings depend on liquid.	FPM (Standard) NBR, PTFE, EPDM
<b>Max. Operating Pressure</b>	400 bar/6000 psi		
<b>Medium Temperature</b>	Standard	-40 ≤ ... 120° C	
	Ex-design	-20 ≤ ... 100° C	
	High temperature	not available	
<b>Viscosity Range</b>	1 ... 100 000 mm <sup>2</sup> /s		
<b>Mounting Positions</b>	unrestricted, on subplate with side or bottom connections		
<b>Filtering</b>	50 µm		
<b>Preamplifier</b>	short circuit proof and reverse polarity proof 10 ... 28 V DC/45 mA, additional current on signal output max. 20 mA		

### OUTPUT SIGNALS OF PREAMPLIFIER

#### VOLTAGE RANGES

Supply voltages:  $U_v = 10 \dots 28 \text{ V DC}$

Impulse voltages:  $U_{pp} = U_v - 1 \text{ V}$

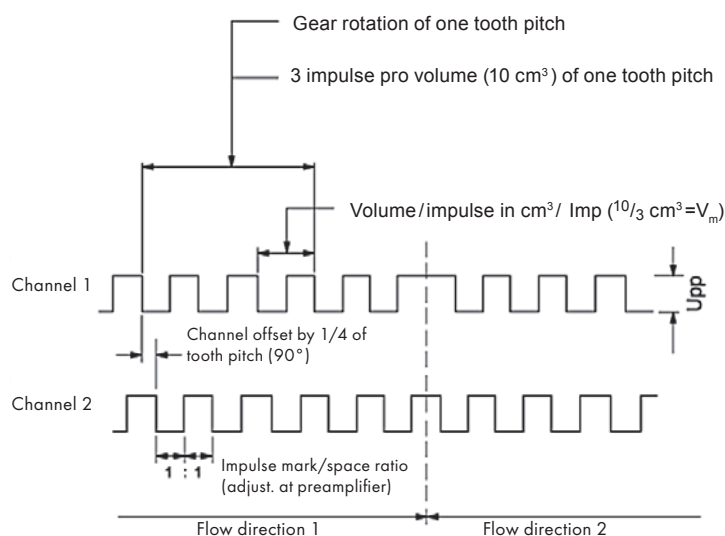

## FLOW RESPONSE CURVES

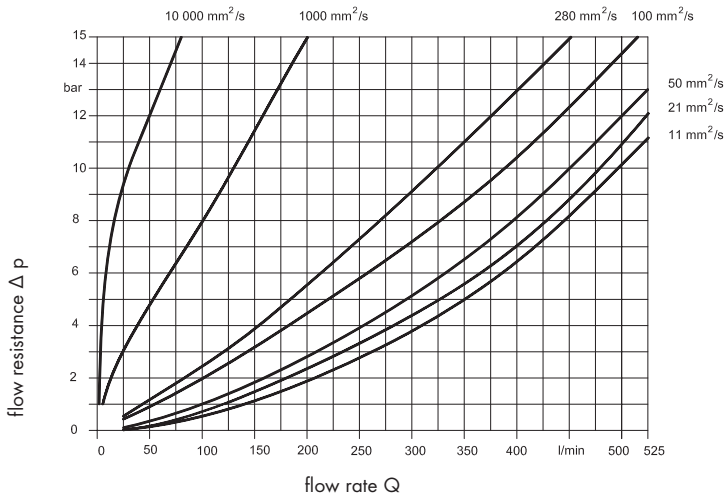

## DIMENSIONS

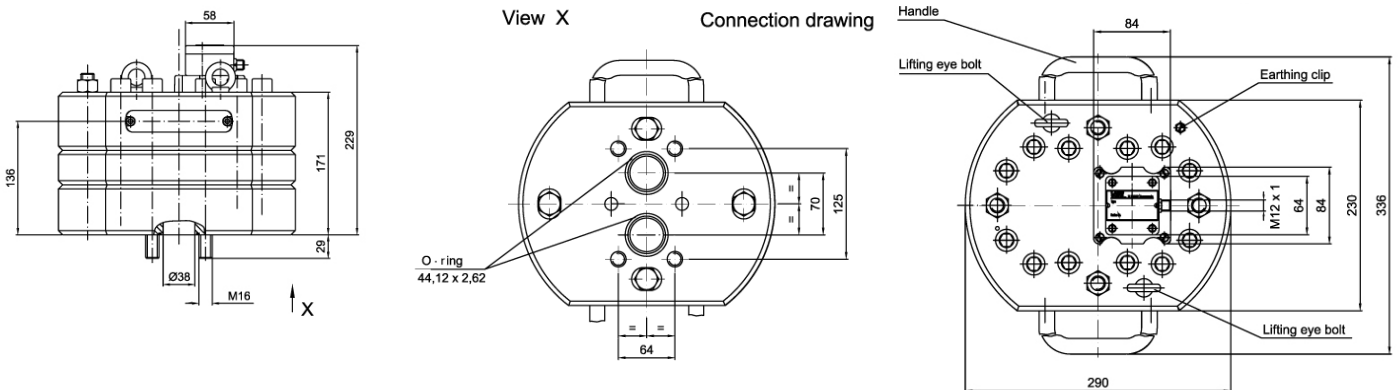

Dimensions are specified in mm

## SUBPLATE DIMENSIONS

APG 10 S GON / 1

APG 10 S WON / 1

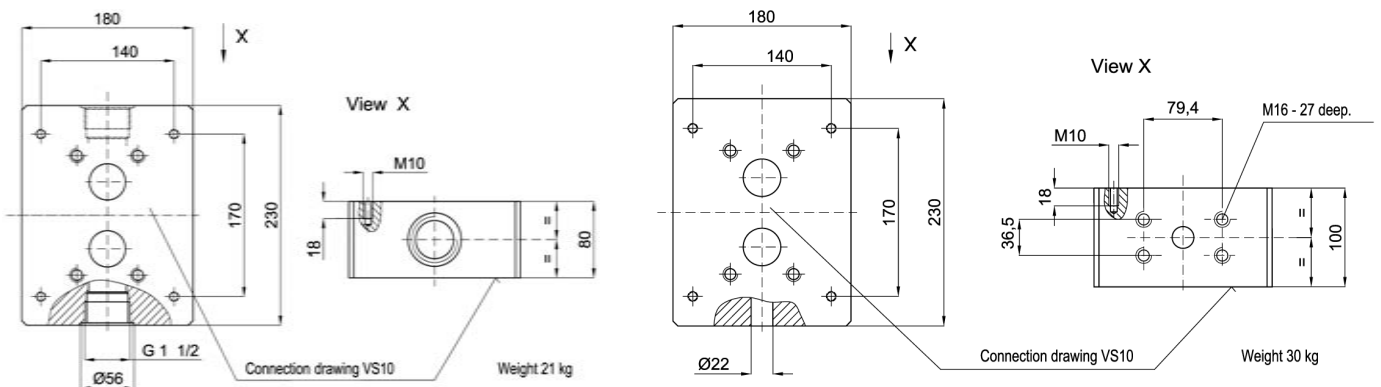

Dimensions are specified in mm

## ► VSE FLOW METERS IN EX-DESIGN / THE BARRIER AMPLIFIER

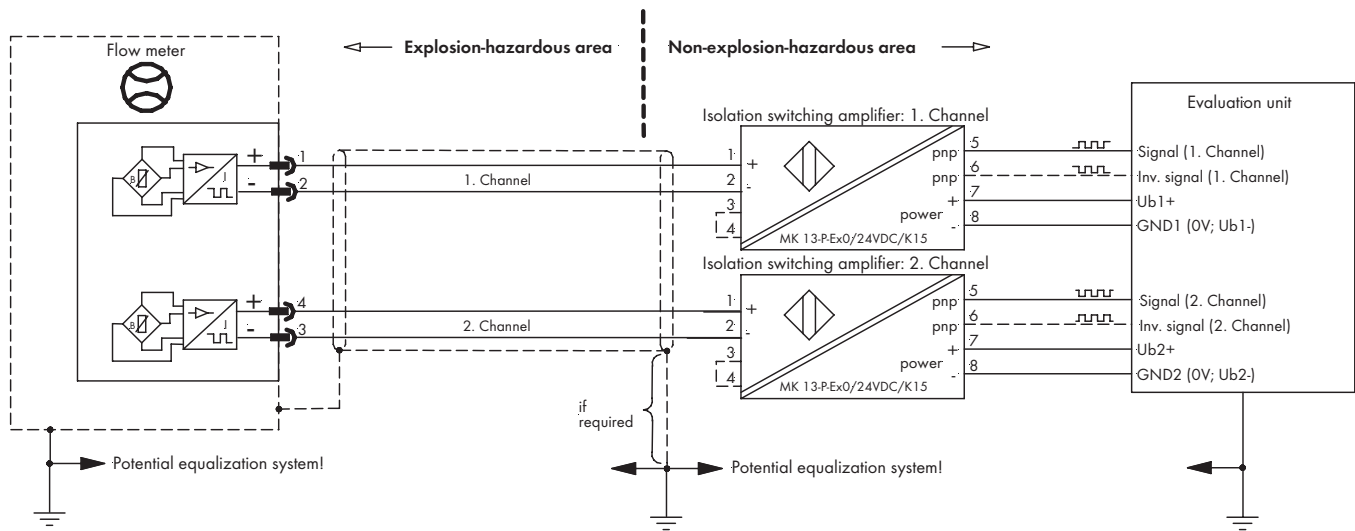

### VSE FLOW METERS IN EX-DESIGN

The VSE flow meters of the VS-series in Ex-design are approved for applications in potentially explosion-hazardous areas and are always operated in conjunction with one or two barrier amplifiers. They have blue markings and offer the necessary Ex-protection security. The type plate shows the necessary description according to DIN EN 50014, the type key and the safety-related and electric data. VSE can supply the flow meters with the barrier amplifiers type MK 13-P-Ex 0/24 VDC/K15.

### THE BARRIER AMPLIFIER MK 13-P-EX 0/24 VDC/K15

The barrier amplifier MK 13-P-Ex 0/24 VDC/K15 enables a galvanic isolated transmission of binary switching status. It has an intrinsically safe control circuit and is certified according to  $\text{Ex II}(1) \text{ GD (EExial) IIC}$ .

There is a galvanic separation from the control circuit to the output circuit and to the power supply. For the transmission of two channels, two barrier amplifiers of this version are necessary. The control circuit can be monitored concerning wire breaking and short circuit (the monitoring can be switched off via a wire jumper).

An error in the control circuit stops the signal output but is not displayed as an error message. Two plus-switching short circuit proof transistor outputs (PNP-outputs) display the digital signal of a channel antivalently.

Flow meter	VSE connection cable, blue, PUR,	Barrier amplifier
Typ VS****-32 Q1*/*	shielded; 4 x 0,34 mm <sup>2</sup>	Typ MK 13-P-Ex 0/24 VDC/K15
BVS 05 ATEX E 071 X	PUR	PTB 06ATEX 2025
$\text{Ex II 1G EEx ia II C T4-T6}$		$\text{Ex II (1) G [EEx ia] II C}$
$U_i = 18,5 \text{ V}$	$R = 0,053 \Omega/\text{m}$	$U_o = 9,9 \text{ V}$
$I_i = 24 \text{ mA}$	$L = 0,85 \mu\text{H}/\text{m} \quad (\text{x})$	$I_o = 22 \text{ mA}$
$P_i = 100 \text{ mW}$	$C_{A-A} = 55 \text{ pF}/\text{m} \quad (\text{x})$	$P_o = 54 \text{ mW}$
$R_i = 0$	$C_{A-S} = 105 \text{ pF}/\text{m} \quad (\text{x})$	
$L_i = 0$	[(x) = measured at 1000 Hz]	
$C_i = 0,27 \mu\text{F}$		
		<b>IIC</b>
		<b>IIB</b>
		Lo/mH
		Co/μF
		1
		5
		10
		2
		10
		20
		1,5
		0,75
		0,65
		5
		3,5
		3

Temperature class	T4	T5	T6
ambient temperature	$-20 \text{ }^\circ\text{C} \leq T_{\text{amb}} \leq 95 \text{ }^\circ\text{C}$	$-20 \text{ }^\circ\text{C} \leq T_{\text{amb}} \leq 70 \text{ }^\circ\text{C}$	$-20 \text{ }^\circ\text{C} \leq T_{\text{amb}} \leq 55 \text{ }^\circ\text{C}$
liquid temperature	$-20 \text{ }^\circ\text{C} \leq T_{\text{Med}} \leq 100 \text{ }^\circ\text{C}$	$-20 \text{ }^\circ\text{C} \leq T_{\text{Med}} \leq 75 \text{ }^\circ\text{C}$	$-20 \text{ }^\circ\text{C} \leq T_{\text{Med}} \leq 60 \text{ }^\circ\text{C}$

► **PICK-UP SYSTEM FOR HIGH TEMPERATURE RANGES**

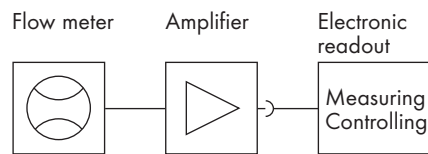

**OPTION FOR STAINLESS-STEEL FLOW METERS VS 0,04 ... VS 4**

- The pick-up system consists of one or two sensor units, which are screwed into the cover of the VS flow meter and of a downstream switched amplifier. This amplifier is connected with the flow meter by means of a temperature resistant cable and has to be installed outside the high temperature area, where the ambient temperature should not exceed 50°C (122°F).

- Depending on the amplifier version, the digital signals are output as PNP or NPN switching signals. The following pictures show the respective connection of the electronic readout:

- For long cable lengths and high input impedance of the readout it is recommended to use shielded cables and a pull-down (PNP-signal) or a pull-up (NPN-signal) resistors.

**CONNECTION: PNP-SWITCHING**

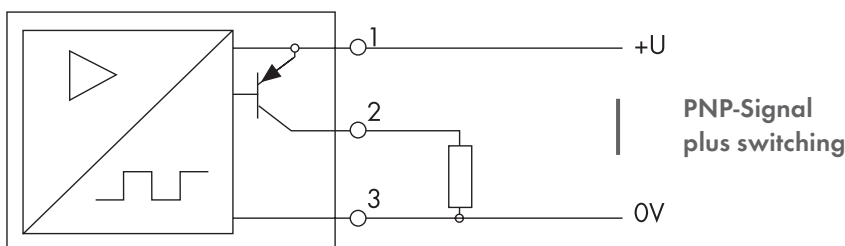

**CONNECTION: NPN-SWITCHING**

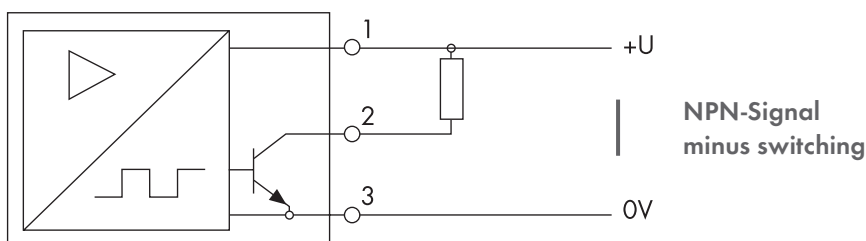

## ► TECHNICAL DATA / FLOW METER DIMENSIONS

### TECHNICAL DATA: SENSOR UNIT

Medium Temperature	-40 °C ... 210 °C
Number of pick-ups	1 or 2 pick-ups
Pick-up	Magnetostrictive
Electrical Connection	PG - cable fitting
Isolation-Protection	IP 64

### TECHNICAL DATA: AMPLIFIER

Supply Voltage	$U_b = 10 \dots 30 \text{ V}$ DC +/- 10-%
Current Consumption	$I_b = \text{ca. } 15 \text{ mA}$ (idle motion, without load)
Signal Output PNP	High Sign: $-U_s = U_b - 1 \text{ V}$ , $I_s = 25 \text{ mA max.}$
Signal Output NPN	Low Sign: $-U_s = 0 \text{ V}$ , $I_s = 25 \text{ mA max.}$
Electrical Connection	4-pole round plug M 12
Max. Ambient Temperature	50 °C
Protection-class	IP 64
Pull-down Resistor	4.7 ... 10 K $\Omega$
Pull-up Resistor	4.7 ... 10 K $\Omega$

### FLOW METER DIMENSIONS

### VIEW X

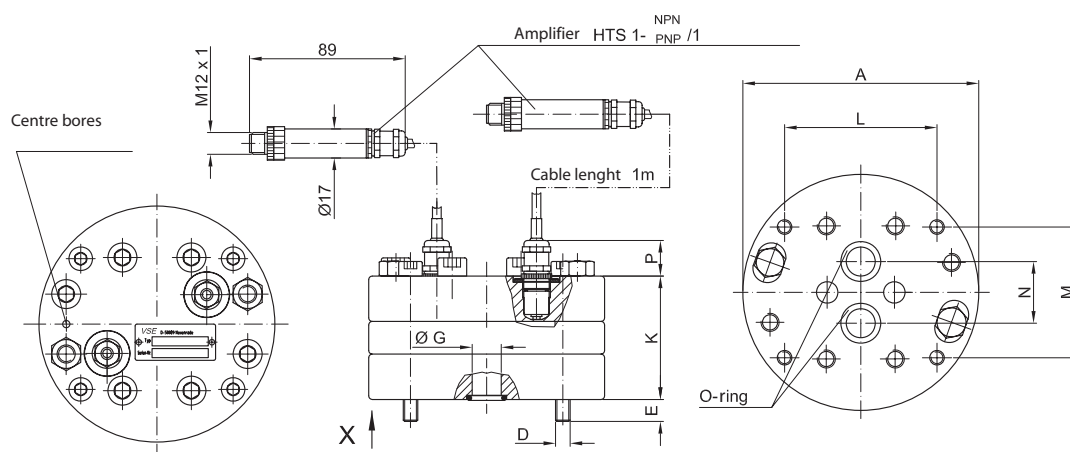

Size	A	D	E	$\varnothing G$	K	L	M	N	P	O-ring	Weight kg
VS 0.04*	100	M 6	11.5	$\varnothing 9$	58.5	70	40	20	22	11 x 2	3.5
VS 0.1	100	M 6	9	$\varnothing 9$	61	70	40	20	22	11 x 2	3.3
VS 0.2	100	M 6	9.5	$\varnothing 9$	60.5	70	40	20	22	11 x 2	3.6
VS 0.4	115	M 8	11.5	$\varnothing 16$	63.5	80	38	34	22	17.96 x 2.62	4.9
VS 1	130	M 8	12	$\varnothing 16$	68	84	72	34	22	17.96 x 2.62	6.7
VS 2	130	M 8	15	$\varnothing 16$	85	84	72	34	22	17.96 x 2.62	8.3
VS 4	180	M 12	20	$\varnothing 30$	110	46	95	45	12	36.17 x 2.62	18.3

\*Attention: \* 0.04 with one (1) channel only

▶ TYPE KEY

TYPE KEY FLOW METERS VS

EXAMPLE

H T		Pick-up system for high temperature ranges (...210°C) signal output PNP or NPN				
-	H	T			/	X

VS 1	G	P	0	1	2	V	-	3	2	N	1	1	/	X
Size	Material	Type of connection	Gear coating	Instruments bearing	Instrument tolerance	Type of seal	Pick-up system	Quantity of pick-up	Signal out-put	Pre-amplifier	Connection	Series	Modification Id. No.	
													X	VSE- 4 pole plug connection (Standard-design)
													0	non pre-amplifier
													1	integrated
													2	external
													N	Supply voltage 10....28V DC (Standard)
													Q	Supply voltage 5 ....10V DC (Ex-design)
													1	1 pick-up
													2	2 pick-up
													3	GMR- Sensor
													V	FPM (Viton) Standard
													P	NBR (Perbunan)
													T	PTFE
													E	EPDM
													1	Reduced tolerance
2	Normal tolerance (Standard)													
3	Increased tolerance													
4	Tolerance steel-plain bearing													
1	Ball bearing													
2	Spindle-bearing													
3	Bronze-plain bearing													
4	Carbon-plain bearing													
5	Steel-plain bearing													
O	No coating (Standard)													
C	Dynamat-coating (C-surface coating)													
T	Titan-coating													
P	Plate construction													
R	Pipe-line connections													
G	EN-GJS-400-15 (VS 10 = EN-GJS-600-3) DIN EN 1563													
E	Stainless steel 1.4305 (V2A)													
H	EN-GJS-600-3 (High pressure) DIN EN 1563													
VS 0,02														
VS 0,04														
VS 0,1														
VS 0,2														
VS 0,4														
VS 1														
VS 2														
VS 4														
VS 10														

► SUBPLATES AP

SUBPLATES AP

EXAMPLE

A	P	G	1	-	S	C	0	N	/	X				
Subplate														
											Connection thread	Accessory connection	Version	Product line
											Accessory connection	N	Standard version	
												S	Special version	
											0	Without rinse connection		
											A	G 1/4		
											B	G 3/8		
											C	G 1/2		
											D	G 3/4		
											E	G 1		
											F	G 1 1/4		
											G	G 1 1/2		
											J	1/4 NPT		
											K	3/8 NPT		
											L	1/2 NPT		
											M	3/4 NPT		
											N	1 NPT		
											O	1 1/4 NPT		
											P	1 1/2 NPT		
S	SAE 1/2													
T	SAE 3/4													
U	SAE 1													
V	SAE 1 1/4													
W	SAE 1 1/2													
X	SAE 2													
S	Side connection													
U	Below connection													
0,2	VS 0,02 to VS 0,2 / VSI 0,02 to VSI 0,2													
0,4	VS 0,4 / VSI 0,4													
1	VS 1 / VS 2 / VSI 1 / VSI 2													
4	VS 4 / VSI 4													
10	VS 10 / VSI 10													
G	EN-GJL-250, EN-GJS-400-15 DIN EN 1561/ 1563													
E	Stainless steel 1.4305													
H	EN-GJS-600-3 DIN EN 1563 (high pressure)													

## ► FLOW METERS WITH HIGH DEFINITION PREAMPLIFIER

### FLOW METERS WITH HIGH DEFINITION FLOW RATE

The preamplifiers of the standard version for flow meters of the "VS" product line output one pulse per tooth-gap volume  $V_z$ , which corresponds to the volume measurement  $V_m$  ( $V_m = V_z / \text{pulse}$ ). This occurs in two channels, so that a maximum resolution of  $1/4 V_z$  for the evaluation of all flanks can be attained. A higher resolution is not possible with these preamplifiers.

As a very high resolution is necessary for precise and exact flow measurements, the volume measurement  $V_m$  must be resolved even more than with conventional preamplifiers. VSE has therefore developed the preamplifier with interpolation, with which a selectable resolution of up to 64 flanks (16 pulses) per period can be attained. This means that you can resolve the volume measurement  $V_m$  with this preamplifier to a maximum of  $1/64 V_m$ . For the evaluation, this means that a part volume of  $1/64 V_m$  from pulse flank to pulse flank (for quadruple evaluation or flank count) is measured, or a full signal pulse is counted as part volume of  $1/16 V_m$  (pulse count) (interpolation  $V_m/16$ ).

This individually programmed high resolution enables you to set the volume measurement  $V_m$  optimally for each provided case of application. Furthermore, new applications can be availed with the higher resolution

- Measuring, controlling and regulating in lower flow ranges
- Measuring, controlling and regulating in zero flow
- Measuring, controlling and regulating in both flow directions
- Measuring, controlling, dosing and filling of small volumes

Flow meters with interpolation electronics (VSI) output two digital signals with programmable high resolution that are phase-offset at  $90^\circ$ . In addition to the signal emission, a zero signal emission is provided, which emits a zero signal at each fully registered volume measurement  $V_m$ .

### SIGNAL EMISSION OF THE PREAMPLIFIER WITH INTERPOLATION

The figure shows the resolution of the volume measurement  $V_m$  with an interpolation factor of 8. This resolves each volume measurement into eight individual part volumes. A pulse on the signal output of channel 1 or channel 2 thus has a value of  $V_m^* = V_m/8 = 1/8 V_m$  per pulse. In double evaluation (flank evaluation of one channel) this results in a value of  $1/2 V_m^* = V_m/16 = 1/16 V_m$  and for quadruple evaluation (flank evaluation of both channels) the result is a value of  $1/4 V_m^* = V_m/32 = 1/32 V_m$  per flank. Evaluation electronics

can recognize flow direction from signals offset at  $90^\circ$ . The preamplifier of the "VSI" product line has a programmed interpolation factor (IPF) with which you can program new, different resolutions. Hence you can program a resolution of 4 to 64 angular steps (see figure 4) per volume measurement  $V_m$ . The frequency multiplication "f\*" is between 1 and 16 (see table).

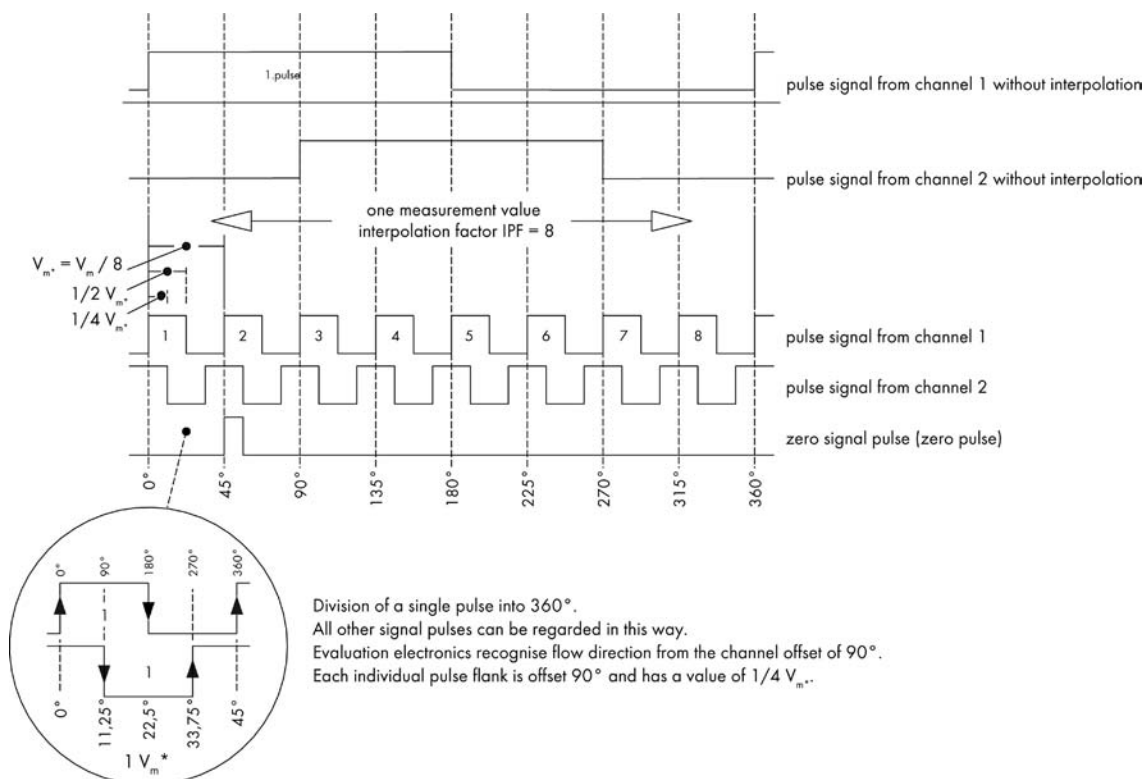



► INTERPOLATION FACTOR AND RESOLUTION

Interpolation factor	Imp/V <sub>m</sub>	Max. resolution (evaluation of signal flanks)	Resolution V <sub>m</sub> <sup>*</sup> (volume measurement V <sub>m</sub> <sup>*</sup> ) [ml]	Max. resolution (angle degrees)	Frequency f <sub>max</sub> <sup>*</sup>
1	1	4 (quadrupling)	V <sub>m</sub> / 4	90°	f <sub>max</sub> × 1
2	2	8	V <sub>m</sub> / 8	45°	f <sub>max</sub> × 2
3	3	12	V <sub>m</sub> / 12	30°	f <sub>max</sub> × 3
4	4	16	V <sub>m</sub> / 16	22.5°	f <sub>max</sub> × 4
5	5	20	V <sub>m</sub> / 20	18°	f <sub>max</sub> × 5
8	8	32	V <sub>m</sub> / 32	11.25°	f <sub>max</sub> × 8
10	10	40	V <sub>m</sub> / 40	9°	f <sub>max</sub> × 10
12	12	48	V <sub>m</sub> / 48	7.5°	f <sub>max</sub> × 12
16	16	64	V <sub>m</sub> / 64	5.625°	f <sub>max</sub> × 16

- Column 1: programmable interpolation factor IPF (programming is done in the factory)
- Column 2: Pulses per volume measurement V<sub>m</sub>
- Column 3: maximum resolution of the signal flanks. The signal flanks channels 1 and 2 are evaluated.
- Column 4: Volume measurement V<sub>m</sub><sup>\*</sup> resulting from the maximum resolution of the signal flanks.
- Column 5: maximum resolution in angle degrees at resolution of signal flanks.
- Column 6: maximum frequency f<sub>max</sub><sup>\*</sup> at maximum flow Q<sub>max</sub> and programmed interpolation factor IPF

In practice the maximum flow Q<sub>max</sub> of the flow meter is seldom run so that a lower frequency can be calculated. The maximum frequency is then calculated according to the following formula:

$$f_{max}^* = \frac{(Q_{max}) * IPF}{V_m} \text{ formula 1}$$

- f<sub>max</sub><sup>\*</sup> / Q<sub>max</sub>: Maximum frequency of the flow meter signals / Maximum flow attained in the case of application described here
- IPF: Programmed interpolation factor
- V<sub>m</sub>: Volume measurement of the flow meter

**Example:** Flow meter VSI 1/10... max. flow rate of the system at maximum capacity  
 Q = 40 l/min = 666.667 ml/sec; IPF = 10;  
 V<sub>m</sub><sup>max</sup> = 1 ml/pulse; f<sub>max</sub><sup>\*</sup> = 6666.67 Hz = 6.66667 kHz

At max. flow<sub>max</sub><sup>\*</sup> = 40 l/min, the flow meter VSI 1/10... outputs a frequency of  
 f<sub>max</sub><sup>\*</sup> = 6666.67 Hz.

▶ TYPE KEY

TYPE KEY FLOW METERS VSI

EXAMPLE

VSI 1	/	4		G	P	O	1	2	V	-	3	2	W	1	5	/	X	.	.
Works-determine to the application																			
Works-determine to the application																			
Meter tolerance																			
Seal type																			
Sensor pick-up system																			
Quantity of pick-up sensors																			
Signal output																			
Pre-amplifier																			
Connection																			
Product line																			
Power supply voltage																			
10 ...30 V Power supply volt.																			
X Modification Id. No.																			
1 5 VSE-norm connection (4-pole) 5 pole plug connection																			
1 Integrated (standard design)																			
W VV int. WE (power supply volt. 10 ...30V DC)																			
2 2 Sensors																			
3 GMR-Sensor																			
V FPM (Viton) standard																			
P NBR (Perbunan)																			
T PTFE																			
E EPDM																			
1 Diminished range																			
2 Normal range (standard)																			
3 Enlarged range																			
4 Range steel plain bearings																			
1 Ball-bearings																			
2 Spindle-bearings																			
3 Bronze-plain bearings																			
4 Carbon-bearings																			
5 Steel-bearings																			
O No coating (standard)																			
C Dynamat-coating (C-coating)																			
T Titanium-coating																			
P Plate construction																			
R Pipe-line connections																			
G EN-GJS-400-15 (VSI10 = EN-GJS-600-3) DIN EN 1563																			
E Stainless steel 1.4305 (V2A)																			
H EN-GJS-600-3 DIN EN1563 (high pressure)																			
Size	1	1 Imp. pro $V_z$	$V_m = V_z$ pro Imp	1	3 Imp. pro $V_z$	$V_m = 10/3$ pro Imp													
	2	2 Imp. pro $V_z$	$V_m = V_z/2$ pro Imp.	2	6 Imp. pro $V_z$	$V_m = 10/6$ pro Imp.													
	3	3 Imp. pro $V_z$	$V_m = V_z/3$ pro Imp.	3	9 Imp. pro $V_z$	$V_m = 10/9$ pro Imp.													
	4	4 Imp. pro $V_z$	$V_m = V_z/4$ pro Imp.	4	12 Imp. pro $V_z$	$V_m = 10/12$ pro Imp.													
	5	5 Imp. pro $V_z$	$V_m = V_z/5$ pro Imp.	5	15 Imp. pro $V_z$	$V_m = 10/15$ pro Imp.													
	8	8 Imp. pro $V_z$	$V_m = V_z/8$ pro Imp.	8	24 Imp. pro $V_z$	$V_m = 10/24$ pro Imp.													
	10	10 Imp. pro $V_z$	$V_m = V_z/10$ pro Imp.	10	30 Imp. pro $V_z$	$V_m = 10/30$ pro Imp.													
	12	12 Imp. pro $V_z$	$V_m = V_z/12$ pro Imp.	12	36 Imp. pro $V_z$	$V_m = 10/36$ pro Imp.													
	16	16 Imp. pro $V_z$	$V_m = V_z/16$ pro Imp.	16	48 Imp. pro $V_z$	$V_m = 10/48$ pro Imp.													
VSI 0.02	$V_z = 0.02$ ml																		
VSI 0.04	$V_z = 0.04$ ml																		
VSI 0.1	$V_z = 0.1$ ml																		
VSI 0.2	$V_z = 0.2$ ml																		
VSI 0.4	$V_z = 0.4$ ml																		
VSI 1	$V_z = 1$ ml																		
VSI 2	$V_z = 2$ ml																		
VSI 4	$V_z = 4$ ml																		
VSI 10	$V_z = 10$ ml																		
																	$V_m = \text{Volume (cm}^3\text{)}$		
																	$V_z = \text{the volume between the gear teeth}$		

## ▶ ELECTRONIC DISPLAYS WITH ANALOGUE OUTPUT

### FLOW RATE MEASURING INSTRUMENT MF1 FOR 2-CHANNEL FLOW SENSOR



- Flow direction indication with switching output (0 V/5 V)
- 2 optocoupler limit value outputs, limit value are individually programmable
- Analogue output with flow rate direction dependent voltage-/current-polarity is available
  - 0 ... (±) 10 V
  - 0 ... (±) 20 mA
  - 4 ... 20 mA
- A power supply for flow sensor is integrated 24 V DC/50 mA

### FLOW RATE MEASURING INSTRUMENT DPZ-F FOR 2- OR 1-CHANNEL FLOW SENSOR



- Flow meter type selectable by menu
- Flow meter direction indicator
- 16 Bit-analogue output
  - 0 ... ± 10 V
  - 0 ... ± 20 mA
  - 0/4 ... 20 mA
- 2 limit value outputs
- Semiconductor
- PC-Interface RS 232 or RS 485
- A power supply for flow sensor is integrated 24 Volt DC/100 mA

### FLOW RATE AND VOLUME MEASURING INSTRUMENT PAXI FOR 1- OR 2- CHANNEL FLOW SENSOR



- Flow rate- or volumedisplay programmable, with linearizer function
- 12 Bit-analogue output
  - 0 ... 10 V
  - 0 ... 20 mA
  - 4 ... 20 mA
- 2 limit value-relay outputs
- PC-Interface RS 232
- A power supply for flow sensor is integrated 12 Volt/100 mA

### DPZ-IMP



### FLOW MEASUREMENT DPZ-IMP FOR 1- OR 2-CHANNEL FLOW SENSOR

- Flow meter type selectable by menu
- 16 bit-analogue output
  - 0 ... ± 10 V
  - 0 ... ± 20 mA
  - 0/4 ... 20 mA
- 2 limit value outputs
- Semiconductor
- PC-Interface RS 232 oder RS 485
- A power supply for flow sensor is integrated 24 Volt DC / 100 mA

### VFM 320



### UNIVERSAL MEASURING INSTRUMENT VFM 320 FOR DYNAMIC PROCESS MEASUREMENTS AND CLOSED LOOP CONTROLS

- Flow rate, volume and ratio measurements as well as measurement and control of volume-shots or mass-shots in 2-component mixing systems
- Signal processing of 2 flow sensors with 2-channel signal outputs
- 2 independent dynamic analogue outputs with 16 Bit digital-analogue converter D/A-converter: <math>< 3\text{ms}</math> (0 Hz → 2 kHz → 0 Hz)

The flow rate and volume values are direction dependent

$$(0 \text{ V} \xleftarrow{\text{Flow in direction 2}} 5 \text{ V} \xrightarrow{\text{Flow in direction 1}} 10 \text{ V})$$

or direction independent

$$(10 \text{ V} \xleftarrow{\text{Flow in direction 2}} 0 \text{ V} \xrightarrow{\text{Flow in direction 1}} 10 \text{ V})$$

- Real time output of analogue and digital measurement values
- PC-Interface 1 x RS 232, 2 x RS 485
- Special designs on request

## ▶ ELECTRONIC DISPLAYS WITHOUT ANALOGUE OUTPUT

### GEL 103



### VOLUMEN-PRESETCOUNTER AND BATCH-COUNTER GEL 103 FOR 2-OR 1-CHANNEL FLOW SENSOR

- Display values for actual volume value and 2 volume preset values will be displayed simultaneously
- 2 limited value relay and transistor outputs, 1 transistor output for batch preset control
- Phase discriminator for 2-channel flow rate sensor with single, double or quadruple volume impulse edge evaluation programmable
- A power supply for flow sensor is integrated 24 V DC  $\pm$  10%, max. 60 mA

## ▶ INSTRUMENTS FOR IMPULSE CONDITIONING

### FREQUENCY-/ANALOGUE CONVERTER DIGFU 1



- Converter output signal for operation with 1-channel flow sensor
  - 0 ... 10 V
  - 0 ... 20 mA
  - 4 ... 20 mA
- Converter output signal with flow direction polarity for operation with 2-channel flow sensor
  - 0 ...  $\pm$  10 V
  - 0 ...  $\pm$  20 mA
- Evaluation of flow direction via digital output signal possible if a 2-channel flow sensor is connected
- Proportional to flow frequency a digital output frequency signal with multiplier factor is adjustable

### SIGNAL CONVERTER PGW-1 FOR 2- OR 1- CHANNEL FLOW SENSORS TO CONVERT FLOW SENSOR OUTPUT SIGNALS INTO OTHER VOLTAGE LEVELS

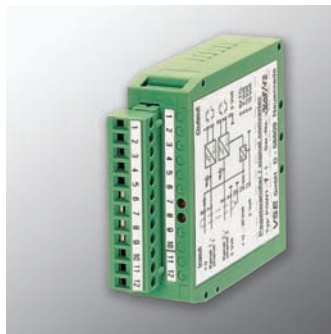

- For example: for chart recorder with impulse input, forward-/reverse-counter, computer, PC- and PLC controls
- Available output voltages: TTL 5 V, 8 V, 12 V, CMOS 15 V
- Power supply/current consumption: 10 ... 30 V DC, 20 mA without flow sensor
- Inverted and non inverted output signal for both channels integrated among other things for connection on differential count inputs to achieve a distortion free signal transmission over long cable distances

### BARRIER AMPLIFIER MK-13



- Economical interfaces with galvanic isolation between intrinsically safe and nonintrinsically safe circuits
- Must be installed in the safe area
- Are used to limit the electrical power into an intrinsically safe circuit in such a way that neither sparks nor thermal effects (hot surfaces) can cause an ignition
- Connection diagram and exact order no. see page 11.

► ACCESSORIES / CUSTOMER SPECIFIC SOLUTIONS

**CUSTOMER SPECIFIC**



- Customer specific solutions can be realized for prices in line with market requirements in the shortest time. We develop your solutions in all current materials such as steel, stainless steel, titanium and aluminium as well as bronze materials.

**PROCESS CONTROL**



- Dyes, paints, (hot-) adhesives or epoxy or PUR-materials also with fillers can be reliably measured. Pressures up to 700 bar and temperatures up to 210° C are included in our standard product range.

**AUTOMOBILE INDUSTRY**



- Whether for installation in vehicles or in climatic exposure test cabinets; we have a solution for almost every measuring application. High reliability, low space requirements and highest measurement accuracy, also for difficult media or aggressive atmospheres distinguish our products.

**ACCESSORIES**



- Connection blocks also heatable, sandwich plates with integrated ball valves and heating jackets for all current flow meters. Additional measuring connections for pressure and temperature **MCS** Micro Control Systems can be supplied from stock.

**REPAIR / CALIBRATION SERVICE**

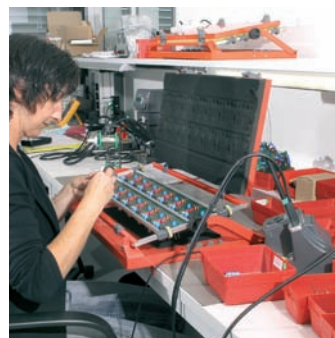
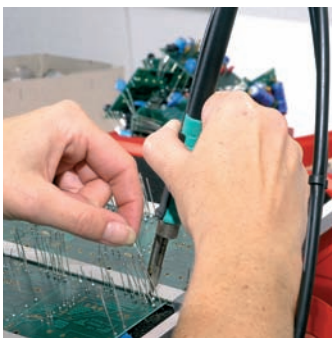

- Inhouse calibrations from 0.002 l/min ... 600 l/min, traceable to a DKD normal. We are pleased to provide you with loan units for the time of repair or calibration. Repair and calibration also of external brands as well as electronic displays.



## WORLDWIDE SERVICE / PRODUCTS

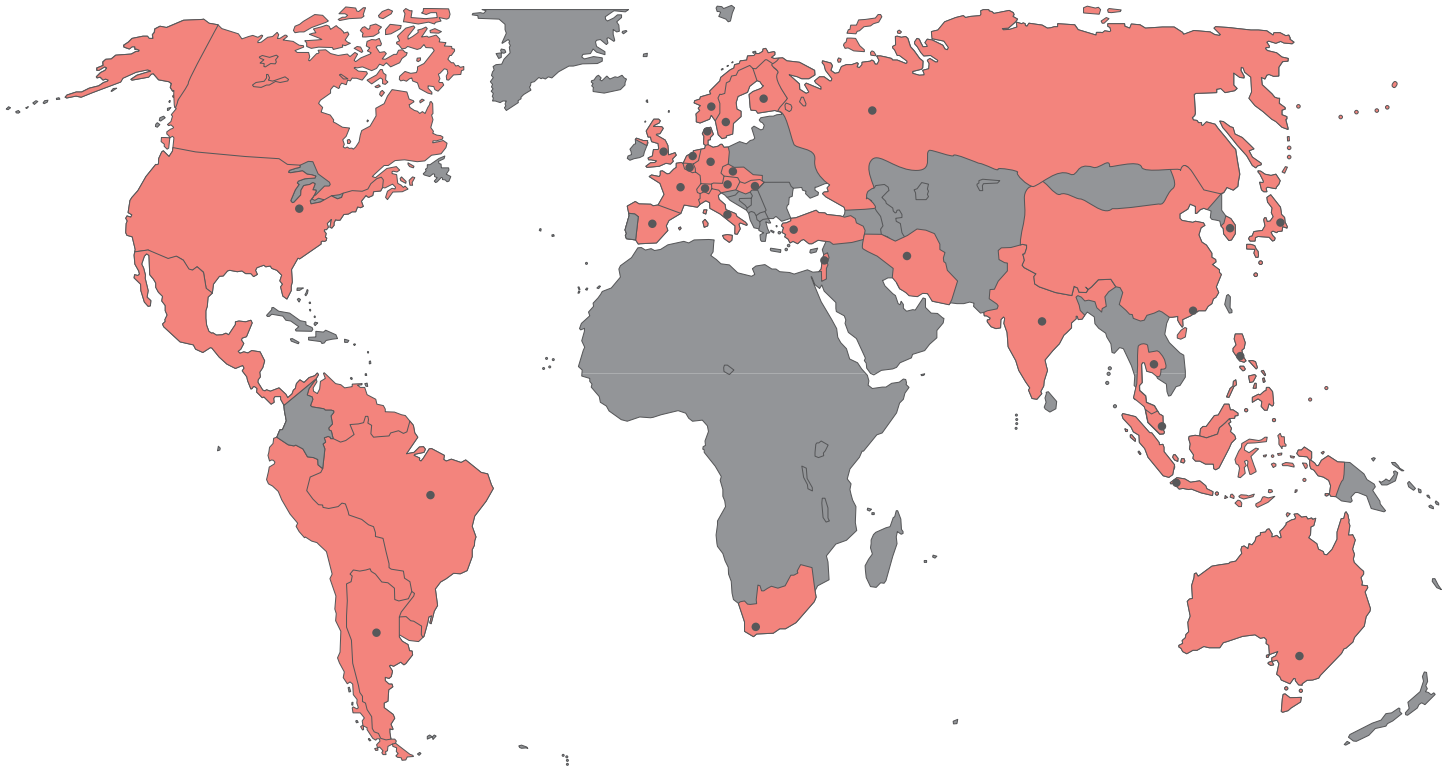

### WORLDWIDE SERVICE QUALIFIED ADVICE THROUGH LONGSTANDING COOPERATION PARTNERS

- personal
- competent
- efficient

### PRODUCTS

- Precision gear flow meters for general industrial applications
- Stainless steel gear flow meters for special applications
- Turbine flow meters
- Standardised and individual electronic readouts
- Electronic devices for special solutions in measurement, control and regulation technology
- Repair and calibration service

distributed by

VSE Volumentechnik GmbH  
Hönnestraße 49  
58809 Neuenrade / Germany

Phone +49 (0) 23 94 / 6 16-30  
Fax +49 (0) 23 94 / 6 16-33

VSE Volumentechnik GmbH  
Postfach / P.O.Box 1229  
58804 Neuenrade / Germany

info@vse-flow.com  
www.vse-flow.com

**VSE<sup>.flow</sup>**  
measurement

  
FLUID TECHNOLOGY GROUP [www.e-holding.de](http://www.e-holding.de)