

Univerza v Ljubljani
Fakulteta za strojništvo



Katedra za strojne elemente in razvojna vrednotenja



Strojni elementi 1

Prirobnične zveze

Miha Janežič¹, Zvonko Majcen¹, Marko Nagode²

¹ Donit tesnit d.o.o

² Univerza v Ljubljani, Fakulteta za strojništvo

Statično tesnjenje brez tesnila

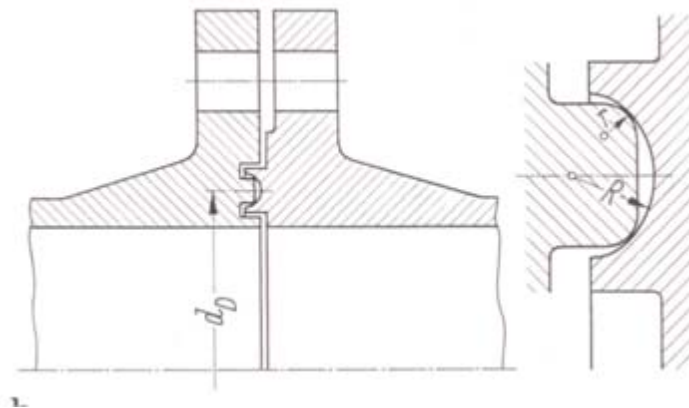
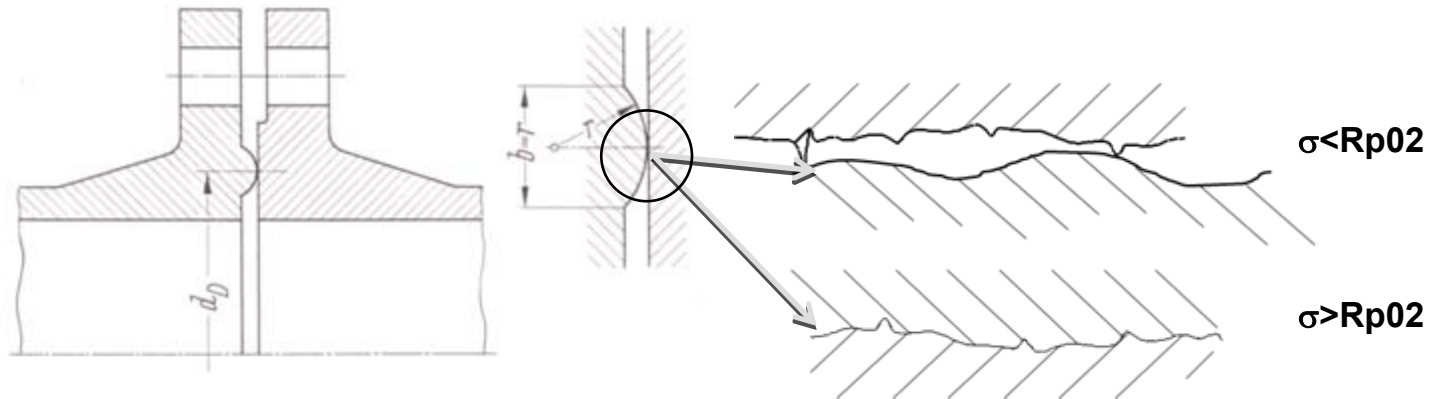

Univerza v Ljubljani
Fakulteta za strojništvo



Katedra za strojne elemente
in razvojna vrednotenja

LABORATORIJ ZA VREDNOTENJE KONSTRUKCIJ

Statično tesnjenje s tesnilom

$$\sigma < R_{p0.2}$$

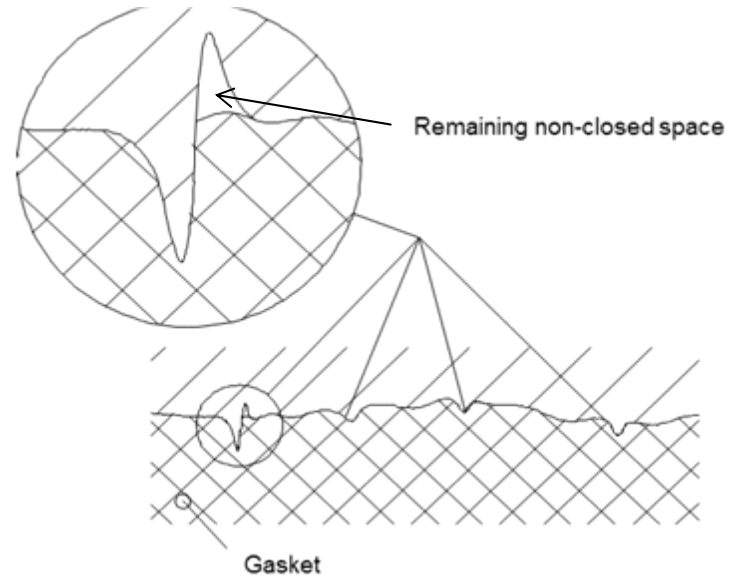
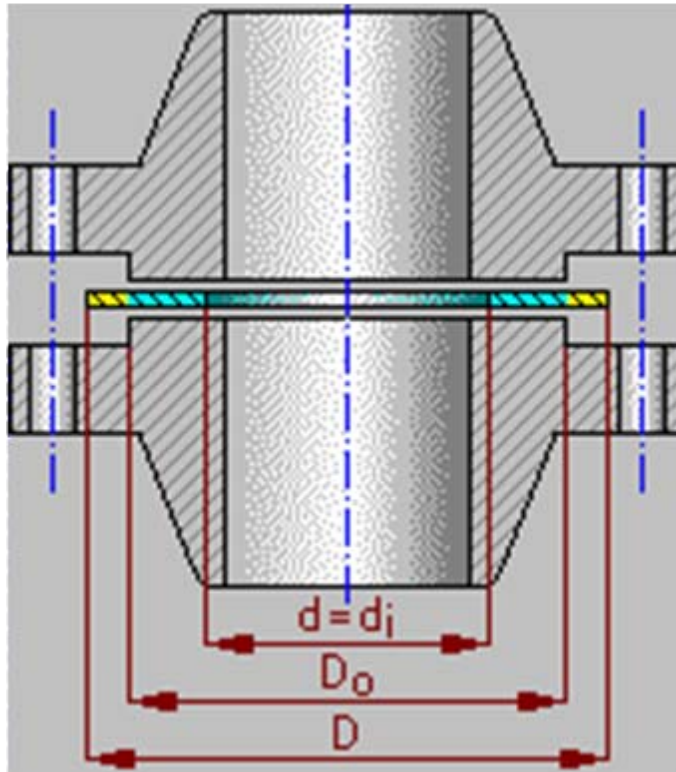

Statična tesnila – delitev glede na material

- Nekovinska – mehka tesnila
- Pol – kovinska tesnila
- Kovinska tesnila
- Tesnilne mse

Univerza v Ljubljani
Fakulteta za strojništvo



Katedra za strojne elemente
in razvojna vrednotenja

Nekovinska – mehka tesnila

- Papir
- Pluta
- Guma
- Tesnilni materiali izdelani po vodnem postopku
- PTFE
- Tekstili
- ~~Kalandrirani materiali z azbestnimi vlakni~~
- Kalandrirani materiali s sintetičnimi (neazbestnimi) vlakni
- Grafit
- Visoko temperaturno odporni materiali (keramika, mica, ipd.)



Pol-kovinska tesnila

- Ojačana mehka tesnila
- Nagubana tesnila
- S kovino oplaščena tesnila
- Spiralna tesnila

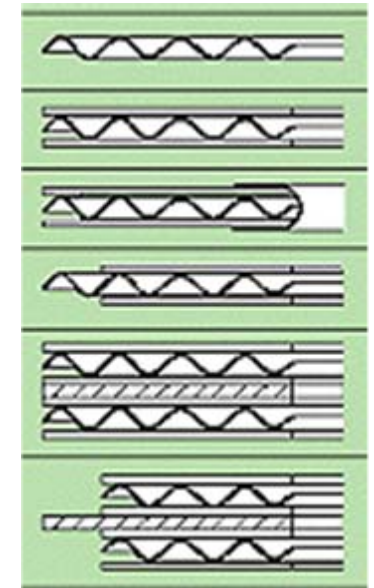
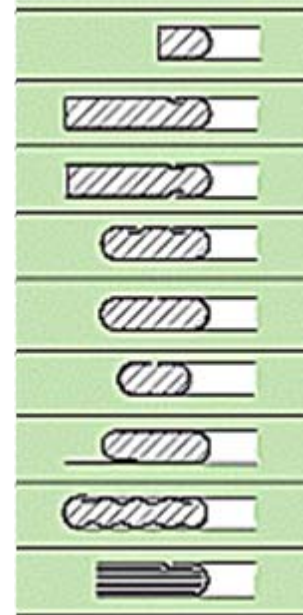
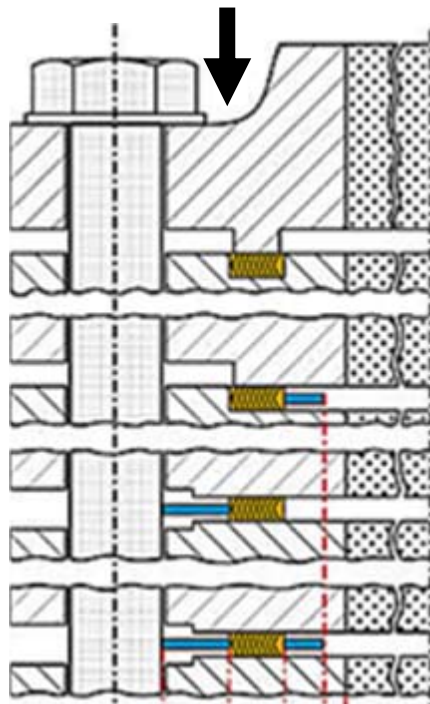
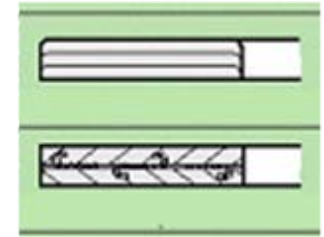

Kovinska tesnila

- Ploščata tesnila
- Ozobljena tesnila
- Tesnilni obroči

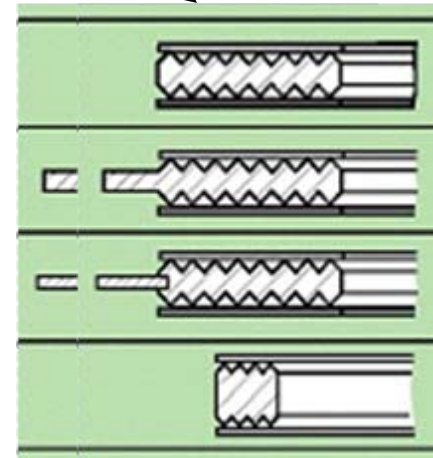
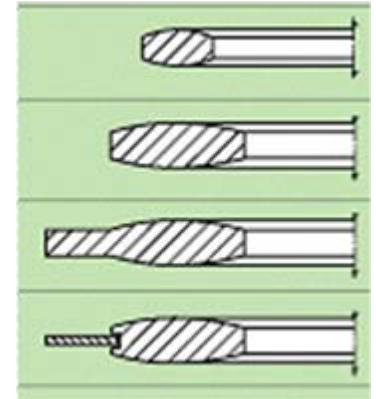
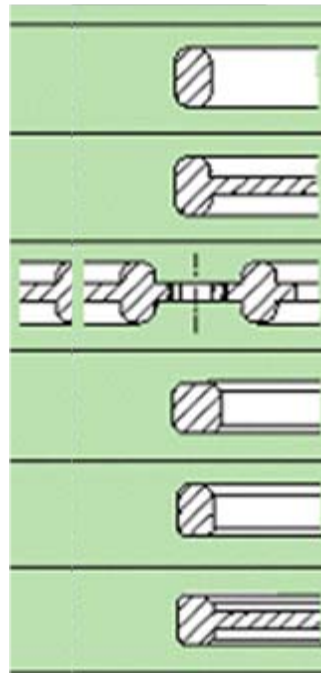

Smernice za izbiro tesnil

Material	Max. temperatura (°C)	Max. tlak (bar)
Obdelan papir	100	10
Z gumo vezana pluta	120	10
Guma	100 (200)	10
Vodni postopek (azbest)	250	25
Vodni postopek (ne-azbestni)	250	25
PTFE	250	50
Kalandrirani azbestni	550	200
Kalandrirani brezazbestni	300	100
Grafit	400*	200
Pol kovinska	800	350
Kovinska	800	1000
Mica	1000	10



Interakcija med prirobnico in tesnilom

- **Tesnost** → je lastnost tesnila
- **Odpornost na lezenje** → **Varnost**

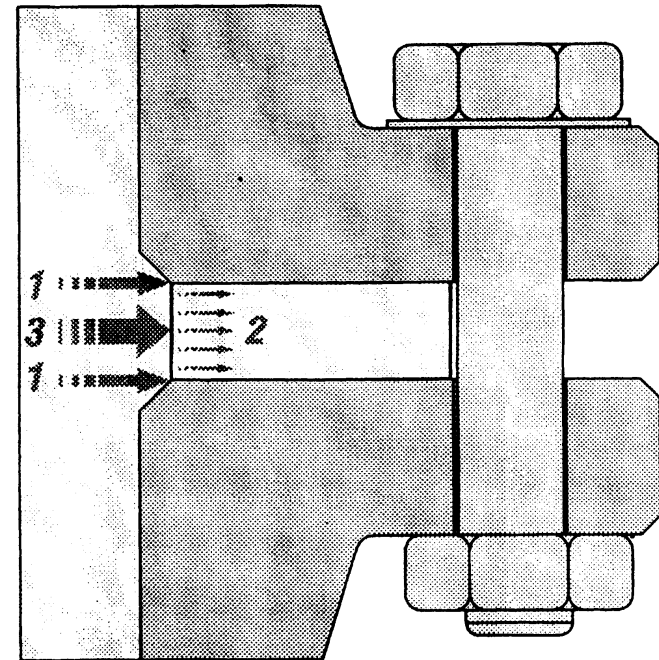

Tesnilo v prirobničnem spoju

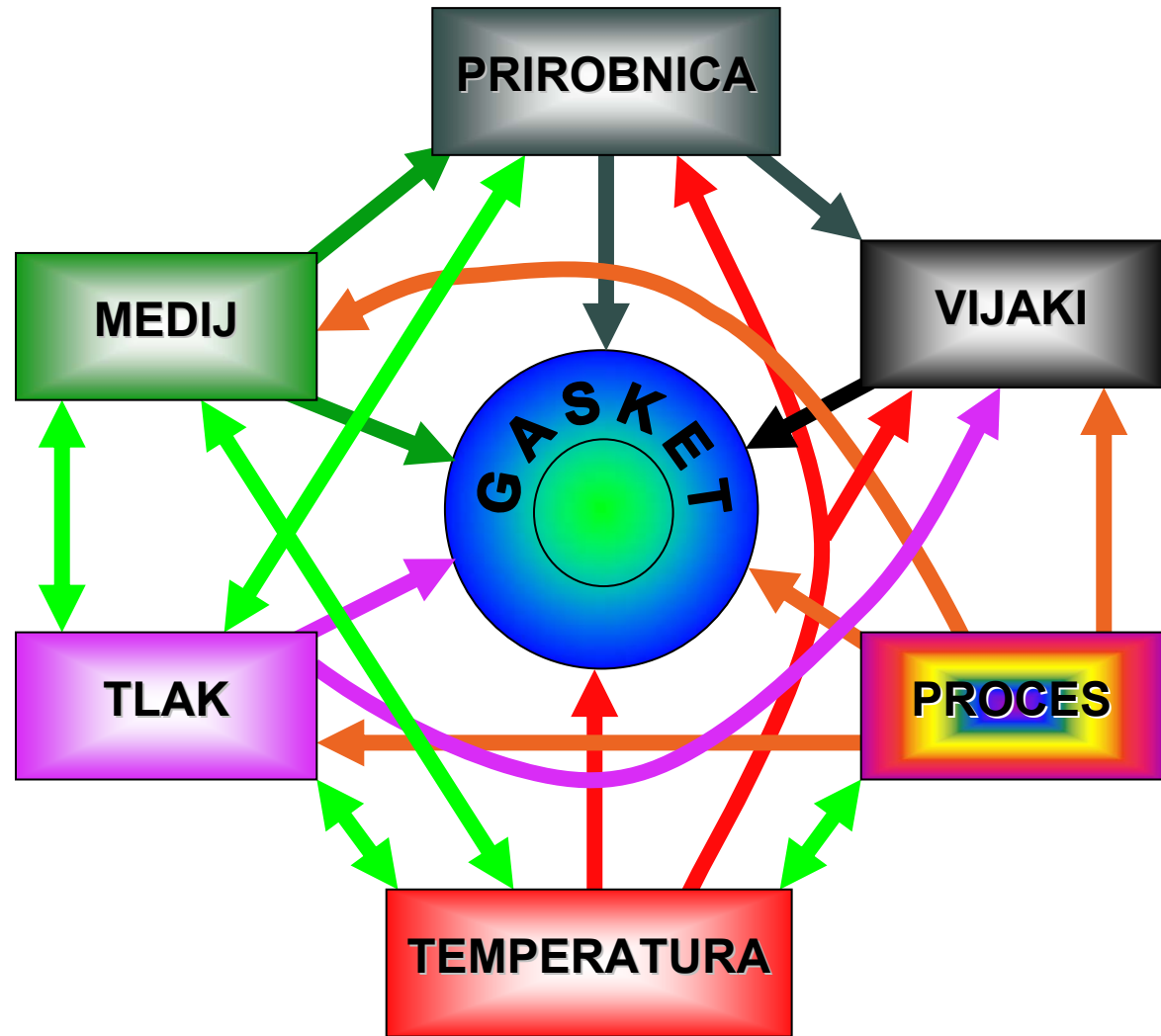

Standardne izvedbe prirobnic

Flat Face (FF)

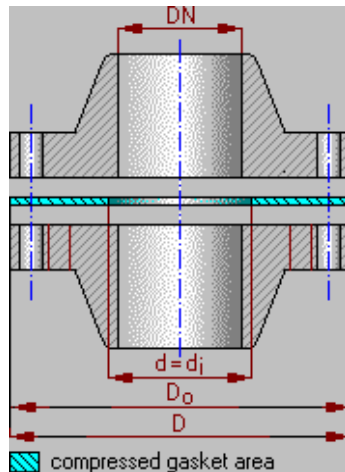

Raised Face (RF)

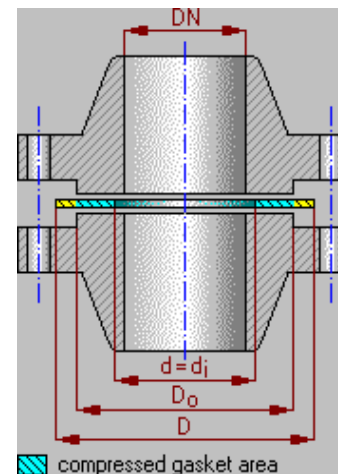

Male and Female

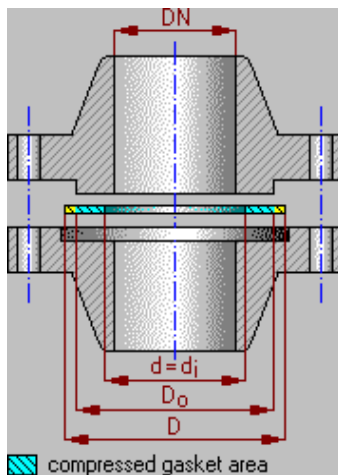

Tongue and Groove

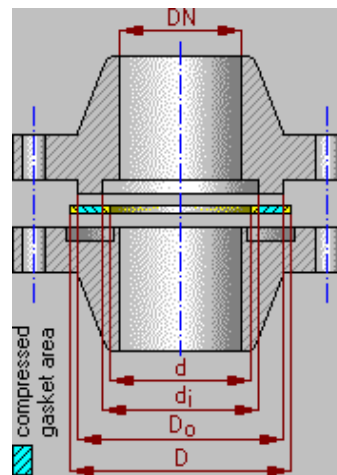

Flat Face and Recess

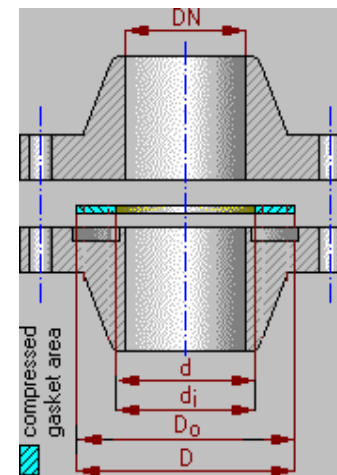

Standardna tipa tesnil

IBC – tesnilo znotraj vijakov

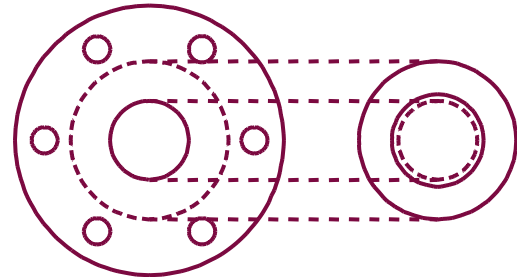

FF – polno tesnilo

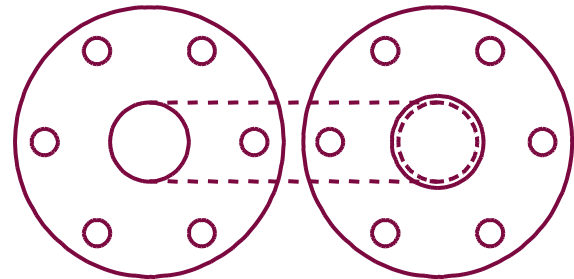

Površinski pritiski na tesnilo – primer zmogljivega materiala

Delovni površinski pritisk pri povišani temperaturi $\sigma_{VB}(T)$ za visoko-kakovostni kalandriran brezazbestni material po standardu *BS 7531 Grade X* debeline 1,5 mm pri povišani temperaturi $T = 300^{\circ}\text{C}$ je:

$$\sigma_{VB}(T) = \sigma_V(T=300^{\circ}\text{C}) \geq 25 \text{ MPa}$$

$$(\sigma_V = 50 \text{ MPa})$$

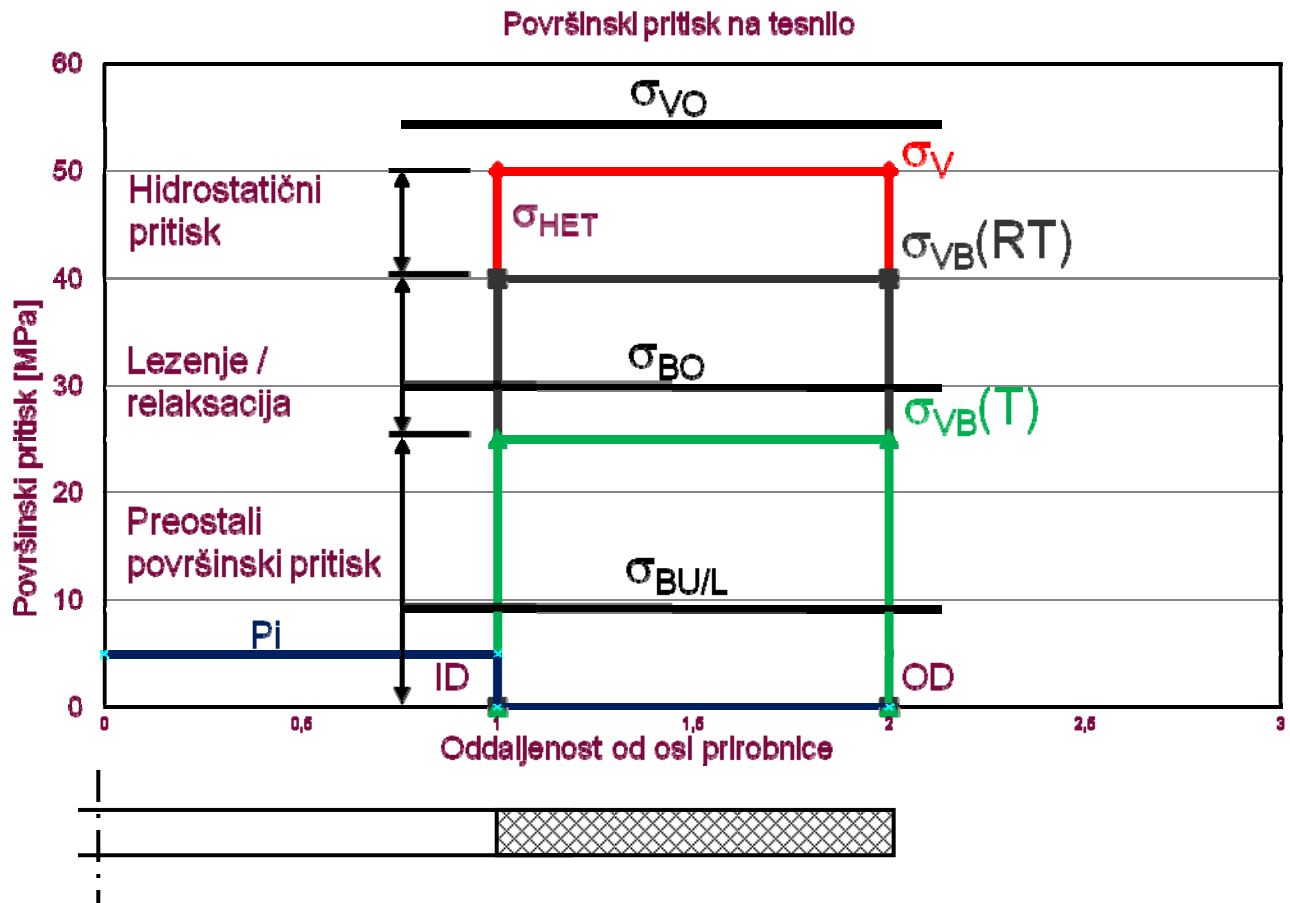

Površinski pritiski na tesnilo – primer manj-zmogljivega materiala

Delovni površinski pritisk pri povišani temperaturi $\sigma_{VB}(T)$ za manj-zmogljivi brezazbestni material debeline 1,5 mm pri povišani temperaturi $T = 300^{\circ}\text{C}$ je:

$$\sigma_{VB}(T) = \sigma_V(T=300^{\circ}\text{C}) \geq 10 \text{ MPa}$$

$$(\sigma_V = 50 \text{ MPa})$$

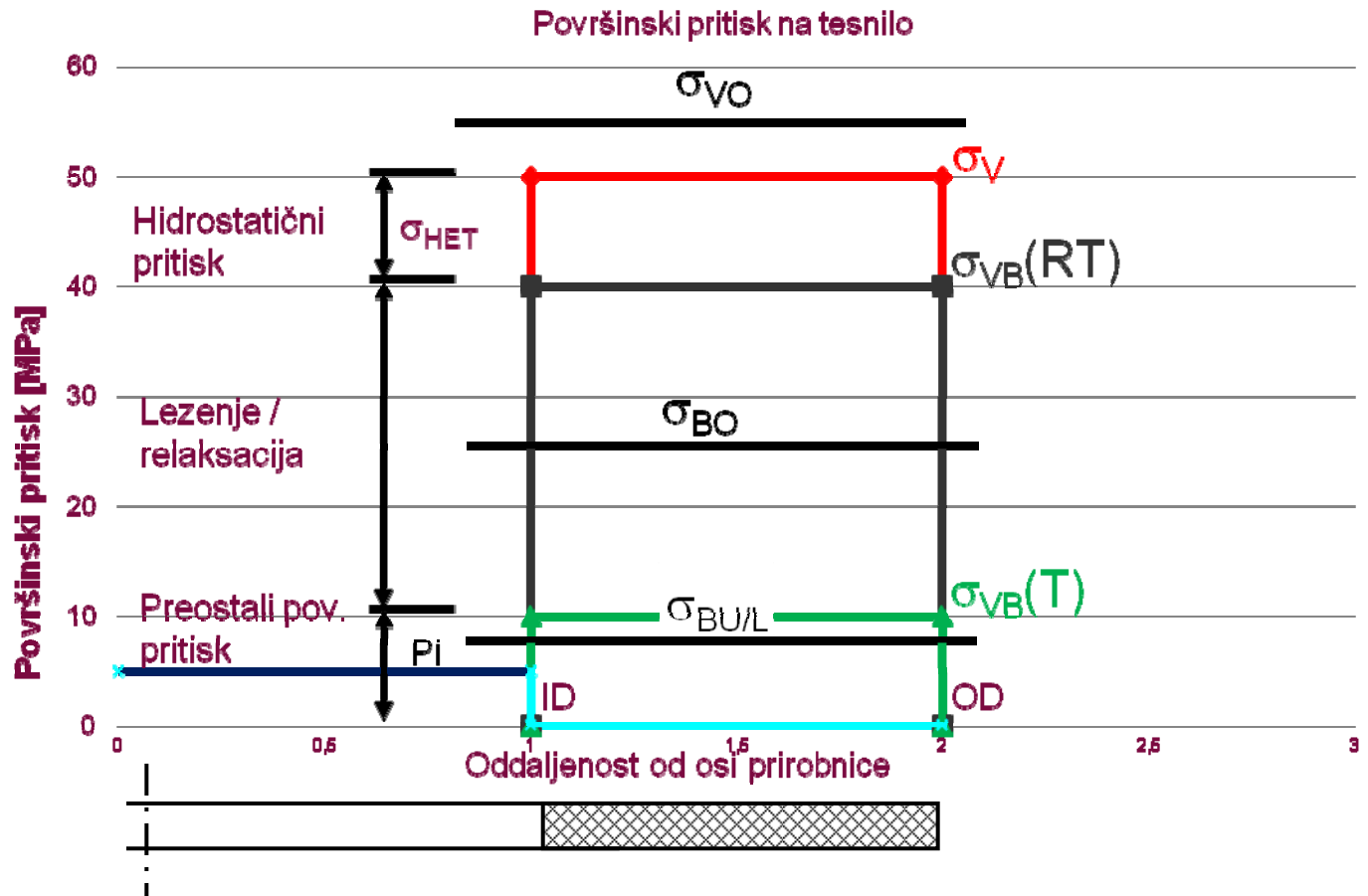

Pojav rotacije prirobnice

- Zaradi pojava rotacije lahko prirobnico na notranjem premeru odpre – zmanjša se efektivna tesnilna površina kar povzroči povišanje površinskega pritiska na tesnilo in v skrajnem primeru celo porušitev tesnila

